



INSTALLATION INSTRUCTIONS

Accessory
ENGINE BLOCK HEATER
P/N 08T44-SJA-200

Application
2007 ACCORD
HYBRID

Publications No.
All 32759
Issue Date
JULY 2006

PARTS LIST

Engine block heater

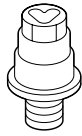

Aluminum washer



Heater harness

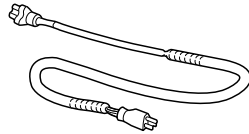

Protective cap

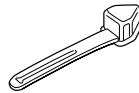

15 Wire ties
(5 Not used)



5 Wire ties with clip
(3 Not used)

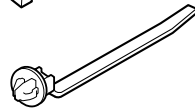

TOOLS AND SUPPLIES REQUIRED

Flat-tip screwdriver

Ratchet

10 mm, 19 mm, 24 mm Socket

Torque wrench

Diagonal cutters

Coolant (Honda Antifreeze/Coolant only)

8 mm Allen socket

White marker

Tape measure

NOTE:

- Always use Honda Antifreeze/Coolant. Using a non-Honda coolant can result in corrosion, causing the cooling system to malfunction or fail.
- To avoid burning out the element, do not operate the engine block heater before it is installed in the vehicle and before you add coolant.

INSTALLATION

Customer Information: The information in this installation instruction is intended for use only by skilled technicians who have the proper tools, equipment, and training to correctly and safely add equipment to your vehicle. These procedures should not be attempted by "do-it-yourselfers."

1. Open the hood, and allow the engine and all cooling system components to cool down.
2. Place a clean drain pan under the radiator drain plug, then remove the drain plug from the bottom of the radiator to drain the coolant. Remove the radiator cap to increase the flow.

NOTICE Radiator coolant will damage paint. Quickly rinse any spilled coolant from painted surfaces.

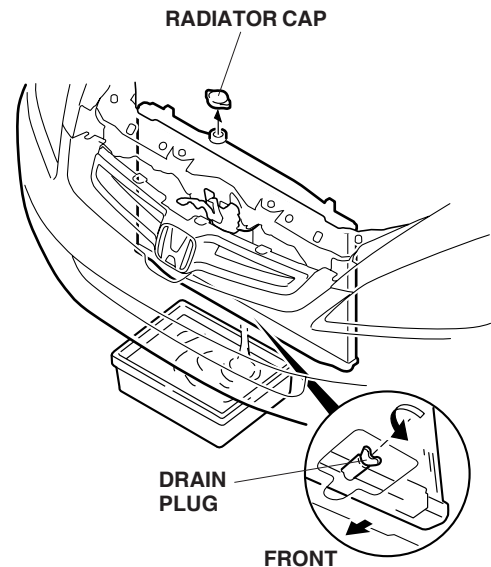

- Remove the air duct cover (two clips).

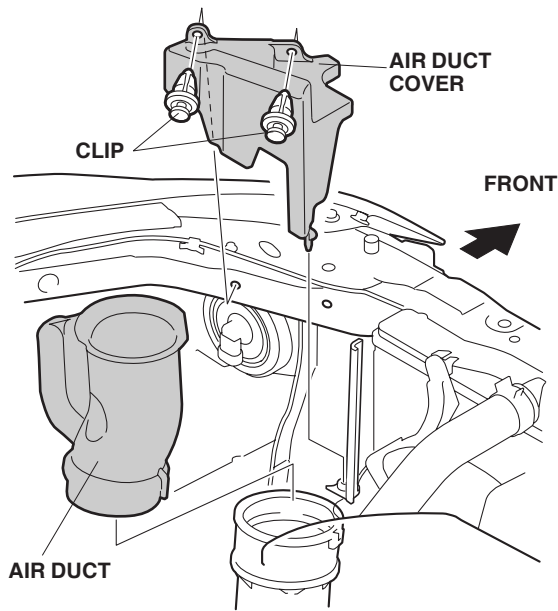

- Remove the air duct by pulling it out toward you.
- Make sure you have the anti-theft code for the radio and navigation system, then write down the audio presets.
- Disconnect the negative (-) cable from the battery. Then open the positive cable cover and disconnect the positive (+) cable from the battery.

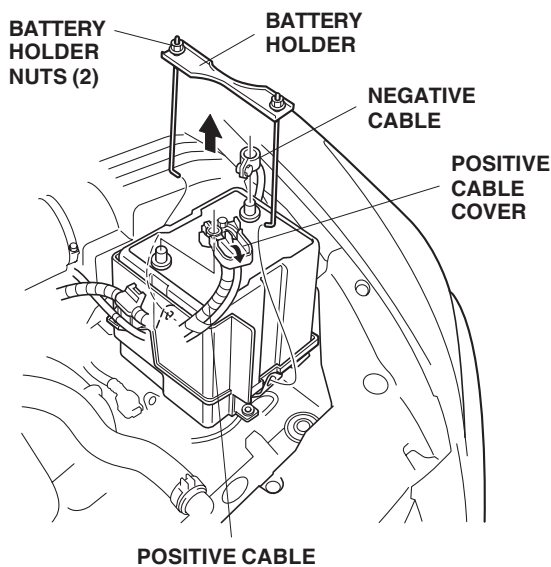

- Loosen the two battery holder nuts, and remove the battery holder.

- Remove the battery cover and battery.

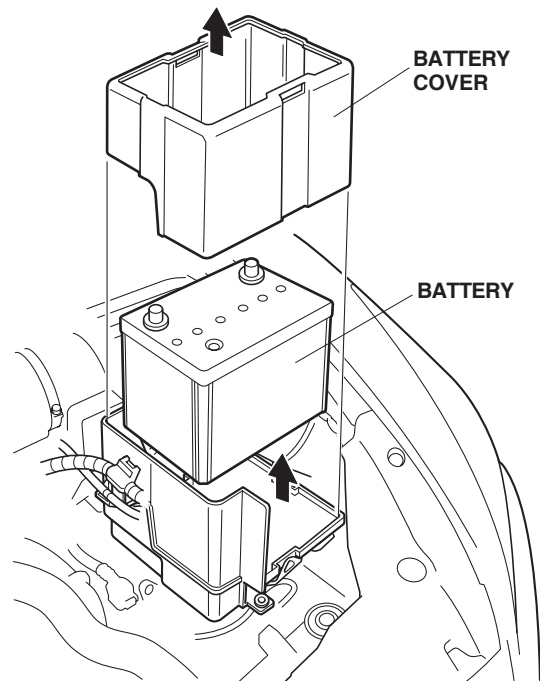

- Remove the positive (+) cable from the battery box (one clip and one wire tie with clip).

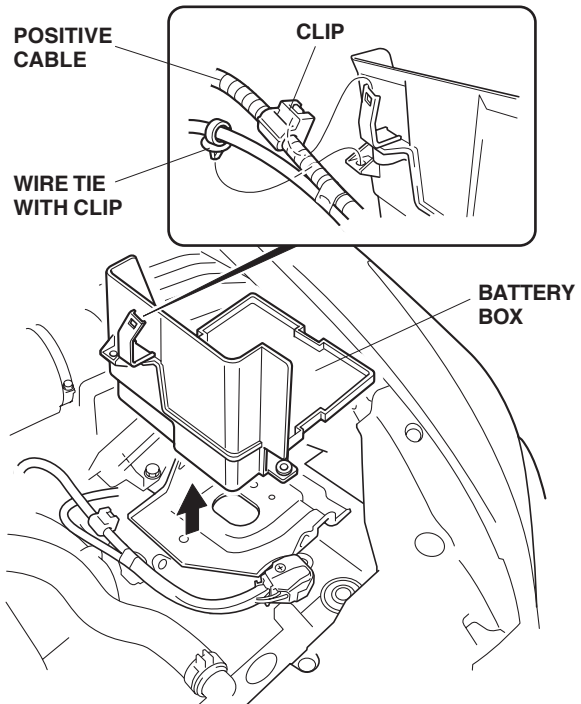

- Remove the battery box.

- Remove the coolant reservoir and coolant reservoir bracket (one bolt).

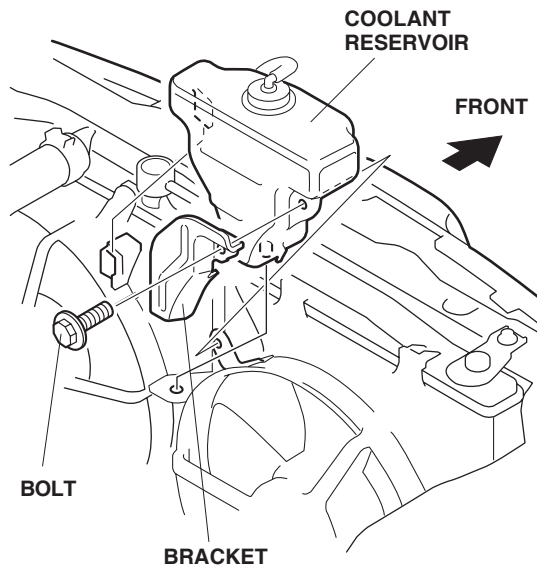

- Remove the drain bolt and washer from the left side of the engine block. Coolant remaining in the engine jackets will flow out of the bolt hole when the bolt is removed. Retain the bolt; it will be used if the engine block heater is removed.

NOTE: Use a new washer if the drain bolt is reinstalled.

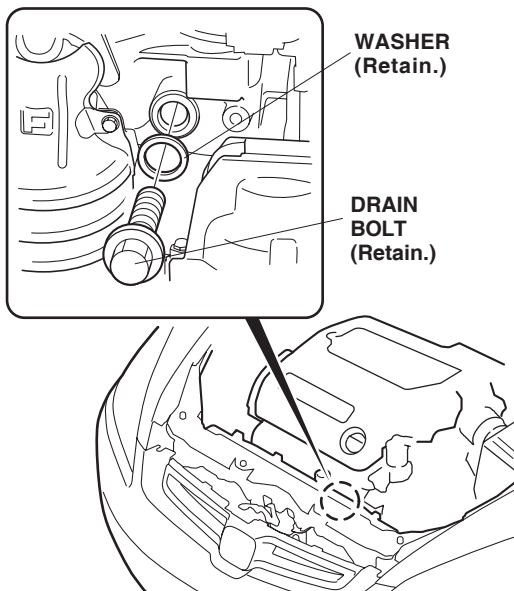

- Install the engine block heater with the aluminum washer into the hole using a 24 mm socket and a torque wrench. Torque the engine block heater to 60 N·m (44 lb-ft).

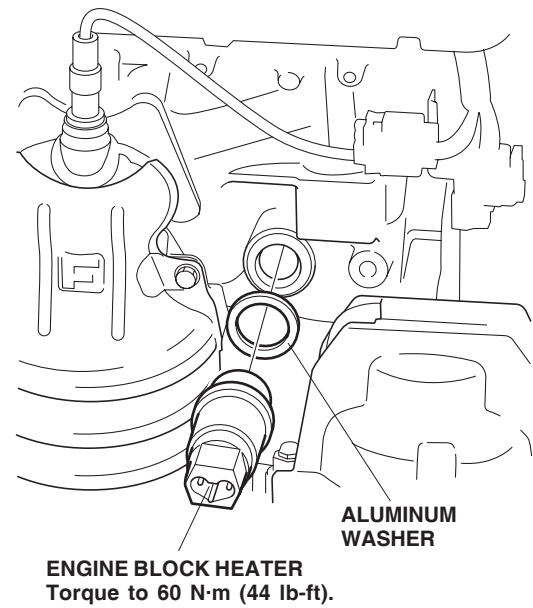

- Using a tape measure and a white marker, measure and mark the heater harness at the measurements as shown.

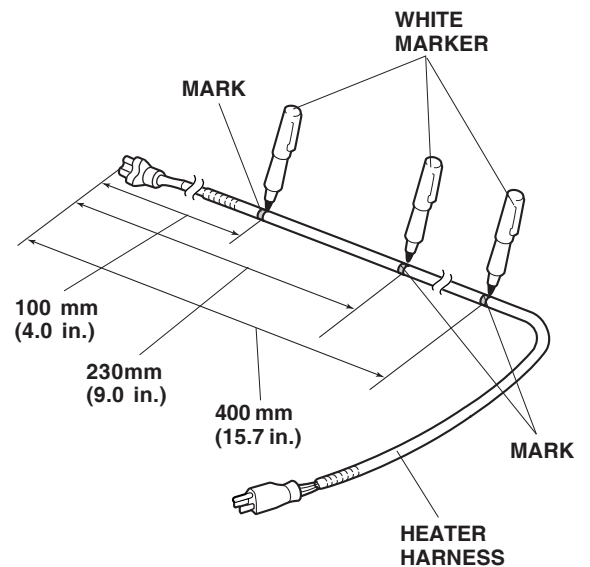

15. Plug the heater harness connector into the engine block heater.

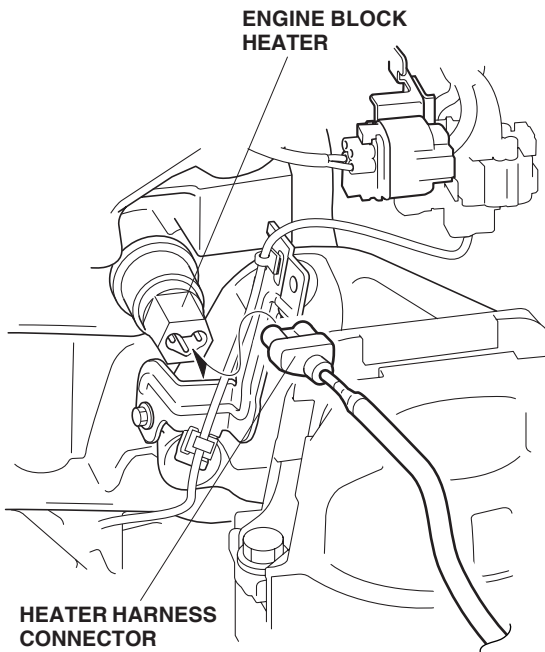

16. Secure the heater harness to the vehicle bracket with one wire tie with clip at the white mark, and secure the heater harness to the vehicle connector with one wire tie at the other white mark.

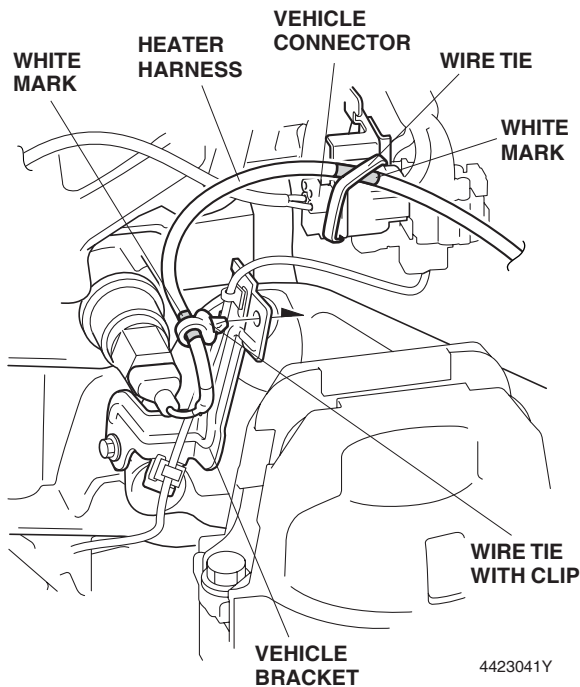

17. Route the heater harness as shown, and secure the heater harness to the fan shroud and vehicle harness with three wire ties. Using a wire tie, secure the white mark point of the heater harness to the fan shroud.

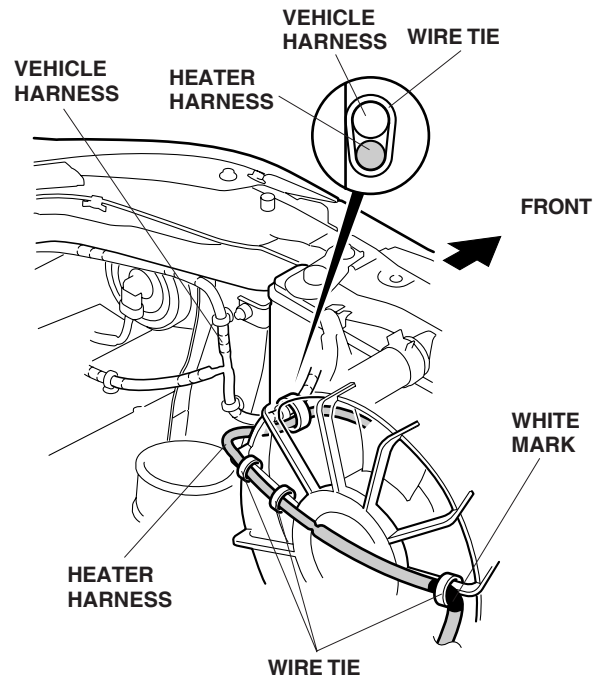

18. Secure the heater harness to the vehicle harness with one wire tie. Do not allow the heater harness to contact the A/C condenser or the radiator.

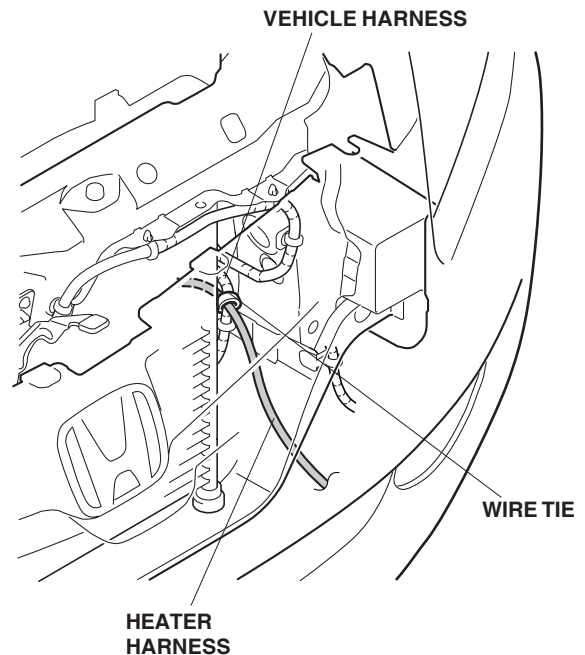

- Continue routing the heater harness along the bumper grille opening, and secure the heater harness to the bumper grille with five wire ties.

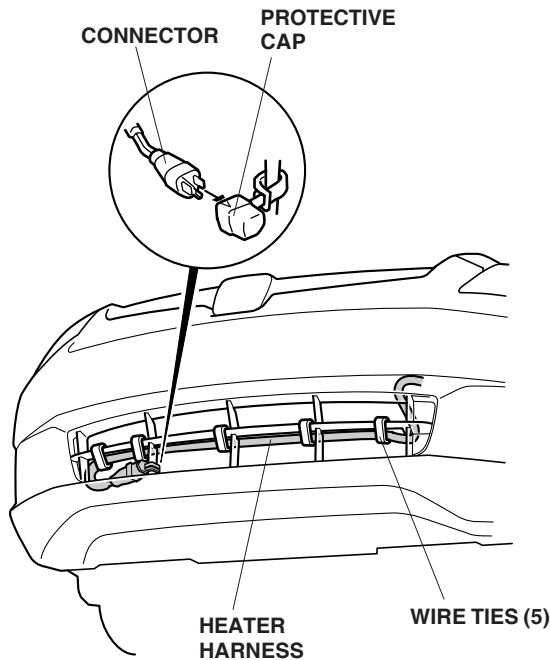

- Attach the protective cap to the grille, and plug the connector of the heater harness into the protective cap.
- Reinstall all removed parts. Check that all clips and fasteners are installed securely.
- Reinstall the radiator drain plug.
- Fill the system with the recommended coolant. Follow the instructions described in the service manual to fill and bleed the cooling system.
- Check the coolant reservoir for correct level and check the cooling system for signs of leakage. Repair as necessary.
- Check that the heater harness is routed properly and all connectors are plugged in.
- Put the drain plug (removed in step 4) in the glove box.
- Reconnect the negative cable to the battery.
- Enter the customer's radio anti-theft code, and reset the radio station presets.
- Reset the clock.
- If the IMA battery level gauge (BAT) displays zero segments, start the engine, and hold it between 3,500 rpm and 4,000 rpm (in Park or Neutral) until the IMA battery level gauge (BAT) displays at least three segments.

NOTE: Whenever the battery is disconnected, the driver's AUTO window function is disabled.

- Start the engine. Push down on the driver's window switch until the window is fully open.
- Pull up on the driver's window switch fully to close the window completely, then hold the switch for 2 seconds.
- Test the AUTO window function.