



INSTALLATION INSTRUCTIONS

Accessory

FRONT BUMPER TRIM
P/N 08P01-SCV-100

Application

2006 ELEMENT

Publications No.

All 31051

Issue Date

OCT 2005

PARTS LIST

Front bumper trim

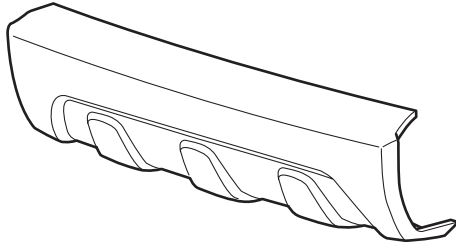

License plate trim

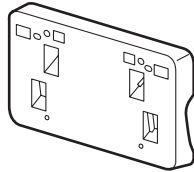

3 Shoulder bolts



2 Flange bolts



4 Self-tapping screws



4 Large clips



5 Clip nuts



4 Spring nuts



2 Small clips



Primer

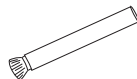

TOOLS AND SUPPLIES REQUIRED

Phillips screwdriver

Flat-tip screwdriver

Drill

3 mm, 8 mm, and 10 mm Drill bits

Ratchet

10 mm Socket

Felt-tip pen

Tape measure

Masking tape

File

Eye protection (face shield, safety goggles, etc.)

Isopropyl alcohol

Shop towel

Center punch

Customer Information: The information in this installation instruction is intended for use only by skilled technicians who have the proper tools, equipment, and training to correctly and safely add equipment to your vehicle. These procedures should not be attempted by "do-it-yourselfers."

INSTALLATION

NOTE:

- Be careful not to damage the body paint.
 - Read the label on the primer before using the primer.
1. Remove the license plate (four screws). Retain two of the license plate screws.

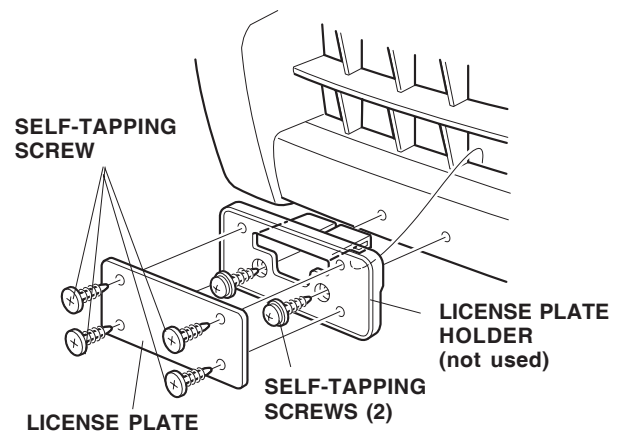

2. Remove the license plate holder (two screws).

- Open the hood, and remove the radiator cover (five clips).

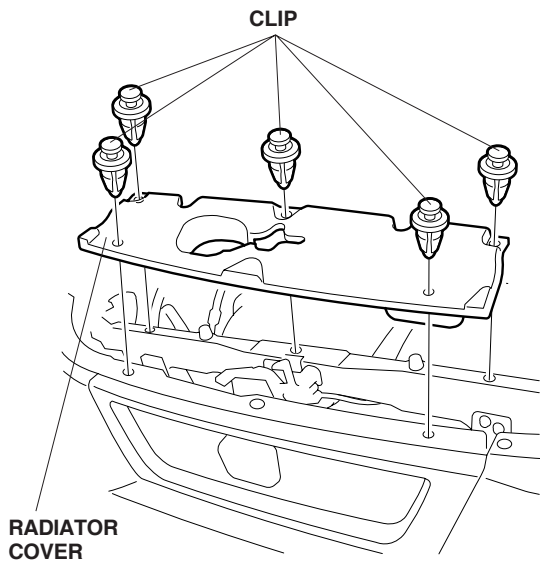

- Remove the front bumper (seven clips at the top, six clips and four stepped bolts at the bottom, and one self-tapping screw on each side).

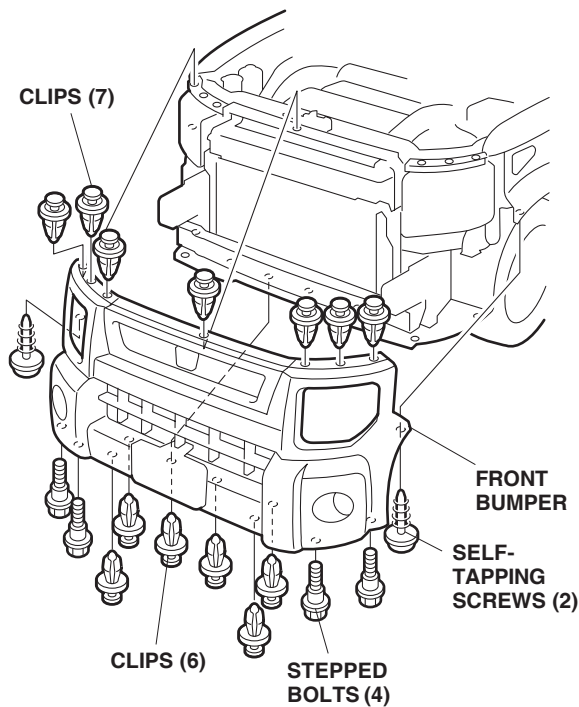

- Starting at the end, pry up on the seven retaining tabs and remove the front bumper trim. Remove one clip at a time. Take care not to damage the retaining tabs.

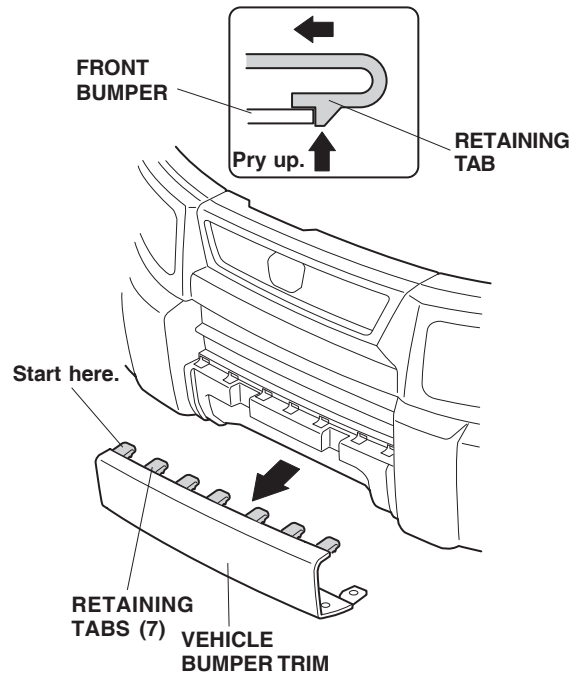

- Place the front bumper upside down, and measure and mark the front bumper with felt-tip pen as shown.

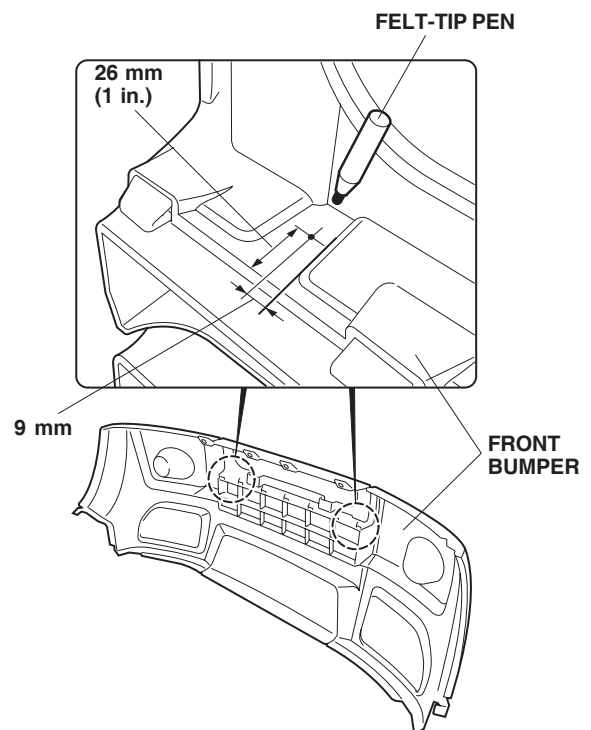

- Lightly center punch the mark made in step 6, then while wearing eye protection, drill a 3 mm pilot hole and finish with a 8 mm drill bit. Remove any burrs from the holes.

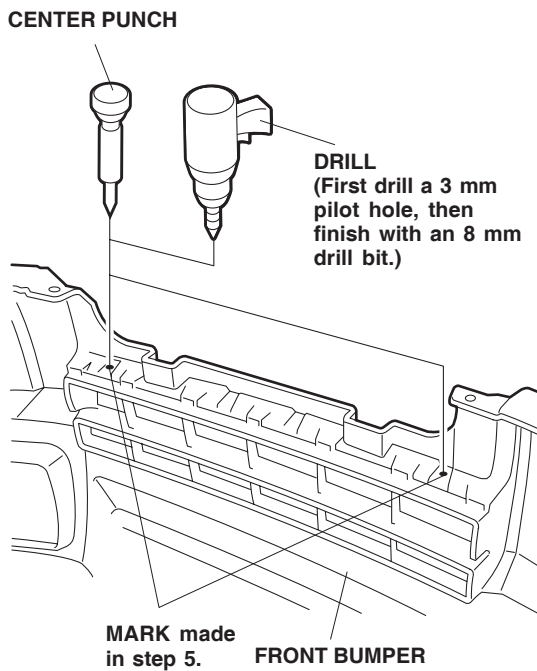

- Reinstall the vehicle bumper trim. Check that the retaining tabs are installed securely.
- Using the felt-tip pen, mark the vehicle bumper trim at the two holes made in step 7, as shown.

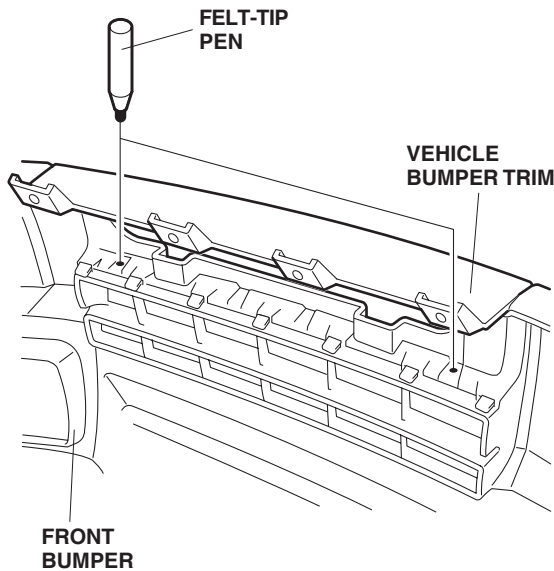

- Remove the vehicle bumper trim.
- While wearing eye protection, drill a 3 mm pilot hole and finish with a 8 mm drill bit. Remove any burrs from the holes with a file.

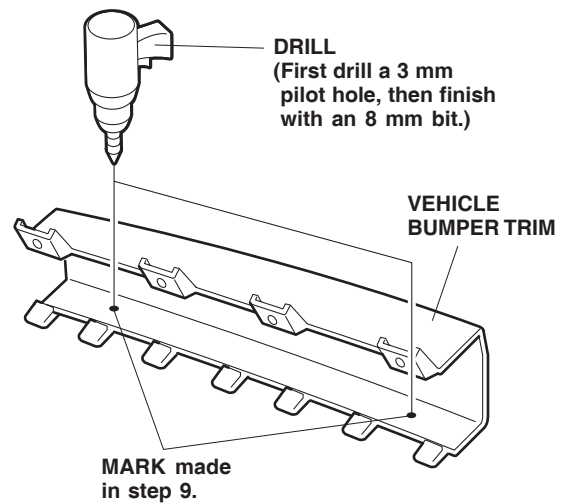

- Using a felt-tip pen and a tape measure, mark the inside of vehicle bumper trim at the two locations shown.

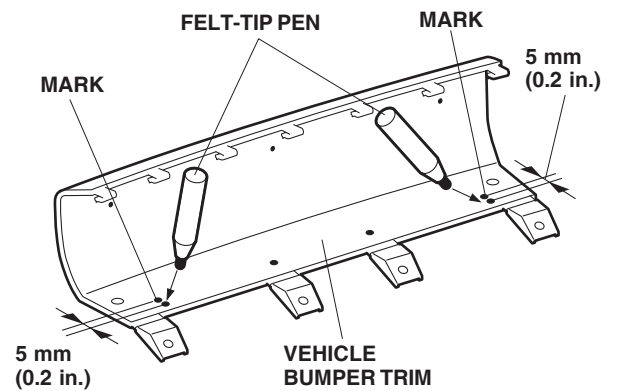

13. Inside the bumper trim, locate the five additional marks, and the two marks made in step 12. While wearing eye protection, drill a 3 mm pilot hole and finish with a 10 mm drill bit at each of the 7 marks. Remove any burrs from the holes with a file.

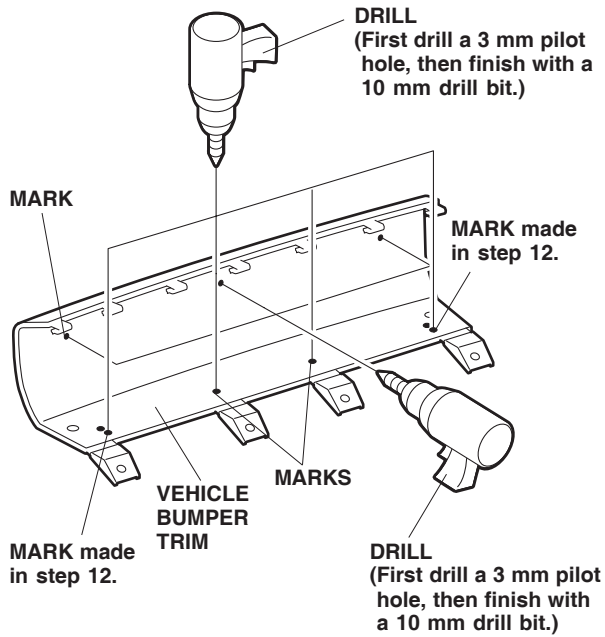

14. On the inside of the front bumper trim, slide a clip nut onto each of the three holders.

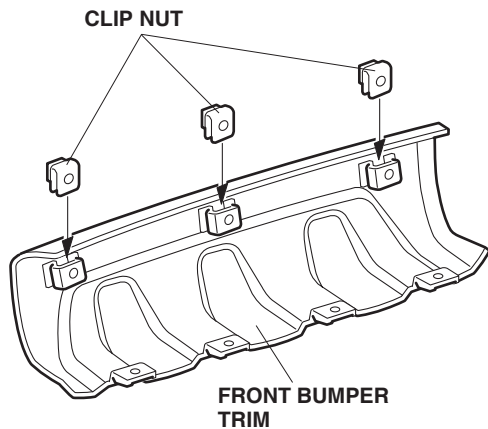

If your state requires a displayed front license plate, continue with step 15; otherwise, go to step 19.

15. Inside the front bumper trim, locate the four marks. While wearing eye protection, drill a 3 mm pilot hole and finish with a 6 mm drill bit. Remove any burrs from the holes.

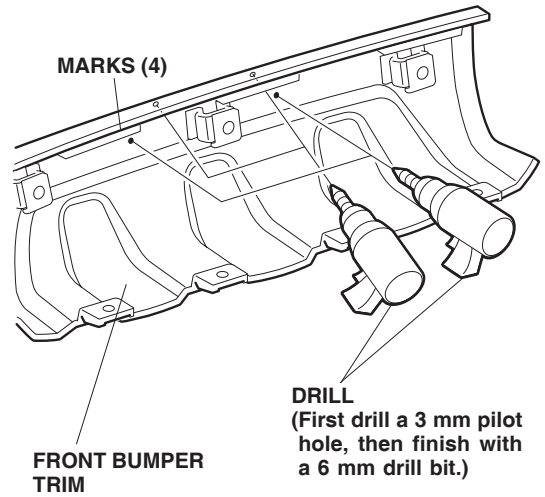

16. Slide four spring nuts and two clip nuts onto the holders on the license plate trim from the kit.

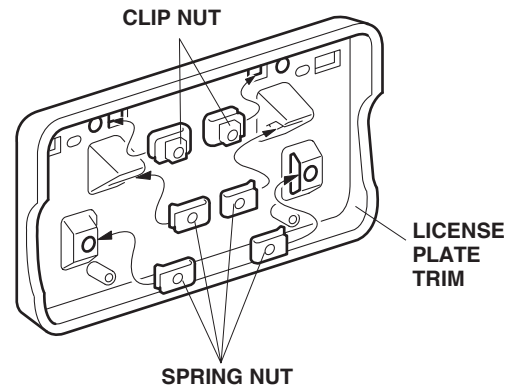

17. Align the license trim with the front bumper trim, and install the four self-tapping screws.

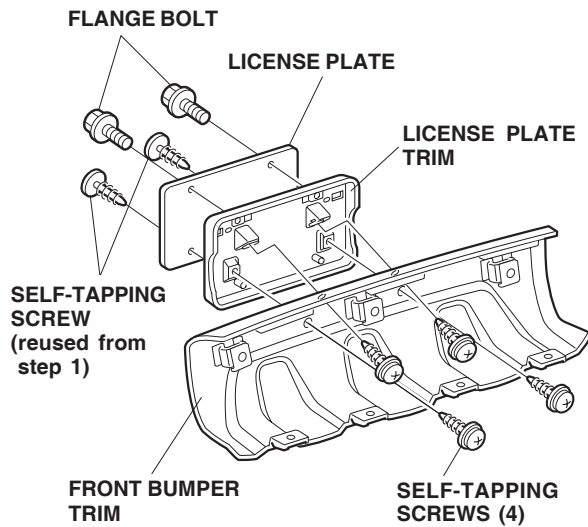

18. Reinstall the license plate using the two flange bolts and two self-tapping screws reused from step 1.
19. On the inside of the front bumper trim, attach a strip of masking tape to the end of each adhesive backing and fold it back 5 to 8 cm (2 to 3 in.). Tape the ends to the front of the front bumper trim.

ADHESIVE BACKING
 (Attach a strip of masking tape to the end and fold back 5 to 8 cm (2 to 3 in.) of adhesive backing from the adhesive tape. Tape the end to the front of the front bumper trim.)

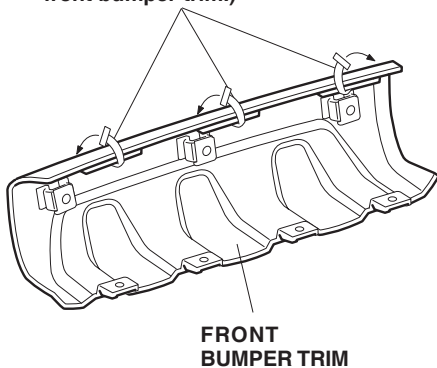

20. Using isopropyl alcohol, clean the vehicle bumper trim in the areas where the adhesive tape on the front bumper trim will attach, then apply the primer.
- Wipe up excess primer at once.
 - Allow the primer to dry for at least 5 minutes before going to the next step.

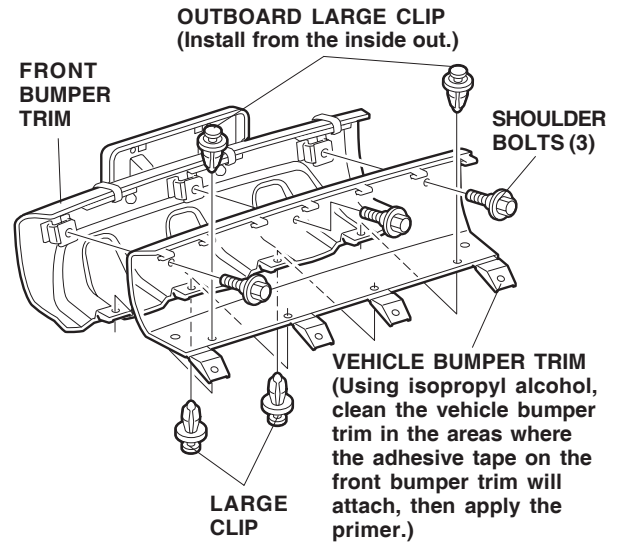

21. Position the front bumper trim on the vehicle bumper trim, and install the three bolts and four clips. The outboard clips are installed from the inside out.
22. While holding light pressure on the front bumper trim, carefully remove the adhesive backings. After attaching, hold the front bumper trim firmly against the vehicle bumper trim with the palm of your hand for 30 seconds.

ADHESIVE BACKING
 (Carefully remove while holding light pressure on the front bumper trim. After attaching, hold the front bumper trim firmly against the vehicle bumper trim with the palm of your hand for 30 seconds.)

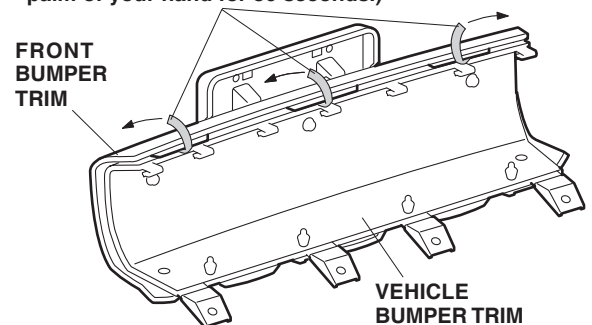

23. Reinstall the bumper trim. Check that the retaining tabs are installed securely.
24. Place the front bumper upside down, and install the two small clips.

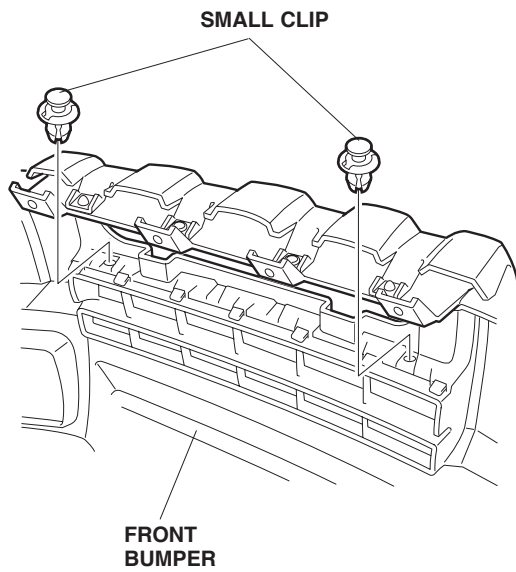

25. Reinstall the front bumper, check that clips and retaining tabs are installed securely.