



INSTALLATION INSTRUCTIONS

Accessory

REAR UNDER SPOILER
P/N 08F03-SVA-100

Application

2006 CIVIC SI

Publications No.

All 31397

Issue Date

NOV 2005

PARTS LIST

Rear under spoiler

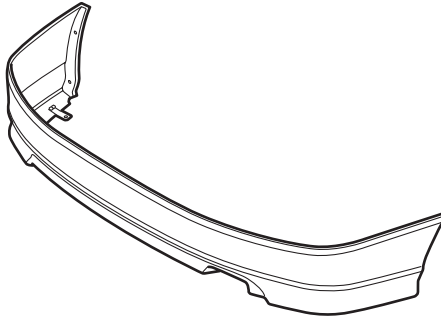

Clip



Rubber washer



6 Flange bolts



6 Flange nuts



4 Self-tapping screws

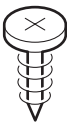

2 Spring nuts

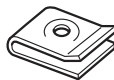

Template

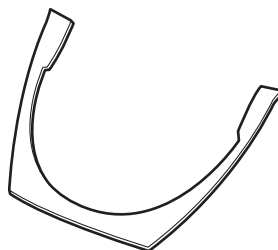

TOOLS REQUIRED

- Phillips screwdriver
- Flat-tip screwdriver
- Hex wrench
- Drill
- 3 mm and 10 mm Drill bits
- Clip remover
- Center punch
- Pushpin
- Hacksaw blade
- Utility knife
- Felt-tip pen
- Scale
- Masking tape
- Isopropyl alcohol
- Shop towel
- Eye protection

INSTALLATION

Customer Information: The information in this installation instruction is intended for use only by skilled technicians who have the proper tools, equipment, and training to correctly and safely add equipment to your vehicle. These procedures should not be attempted by "do-it-yourselfers."

NOTE:

- Be careful not to damage the rear bumper and body paint finish.
- This rear under spoiler kit should be installed only if the ambient air temperature is 60°F (15°C) or above.
- To allow the adhesive to "cure," do not wash the vehicle for 24 hours.

1. Attach the template to the arched section of the rear bumper. Secure the template with strips of tape.

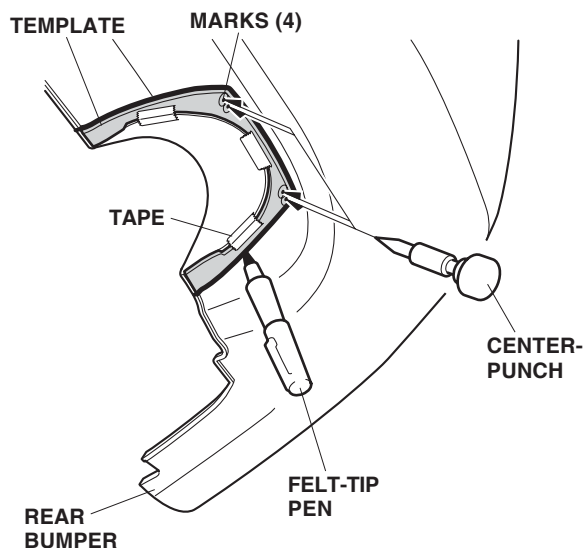

2. Mark the rear bumper along the outer edge of the template with a felt-tip pen, and lightly center-punch the four marks on the template.
3. Remove the template. While wearing eye protection, drill a 10 mm hole through each mark you just made.
 - Using a drill stop on the end of each bit, first drill with a 3 mm drill bit, and finish with a 10 mm drill bit.

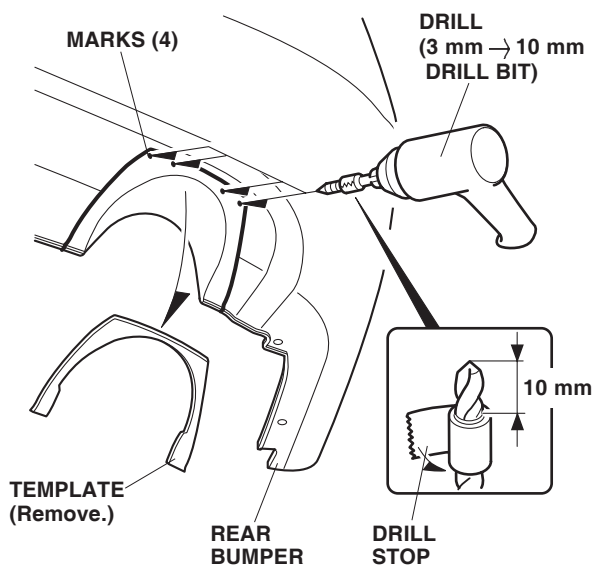

4. Using a hacksaw blade, cut the rear bumper along the lines you made.
 - After cutting, remove any burrs from the edges of the cut section.

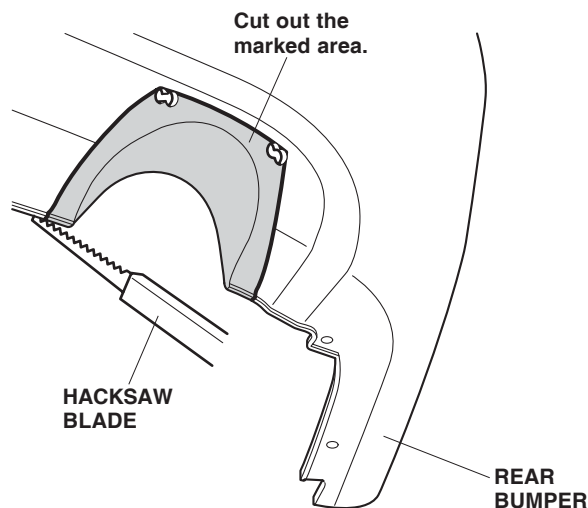

If the vehicle is equipped with a rear inner fender, go to step 7; if not, continue with step 5.

5. Using a drill, drill one 3 mm hole through the lower dimple on the rear bumper on each side.
 - After drilling, remove any burrs from the edges of the holes with a file.

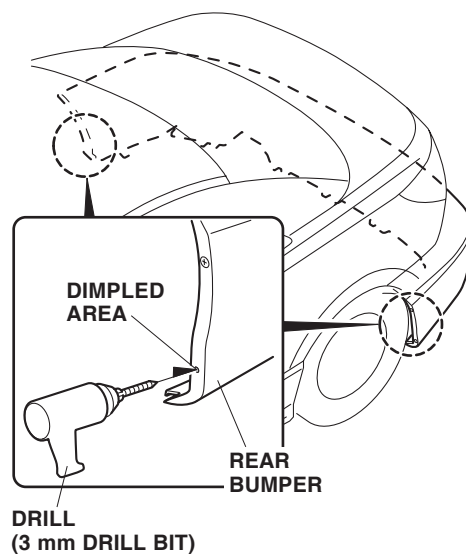

- Slide a spring nut over each hole.

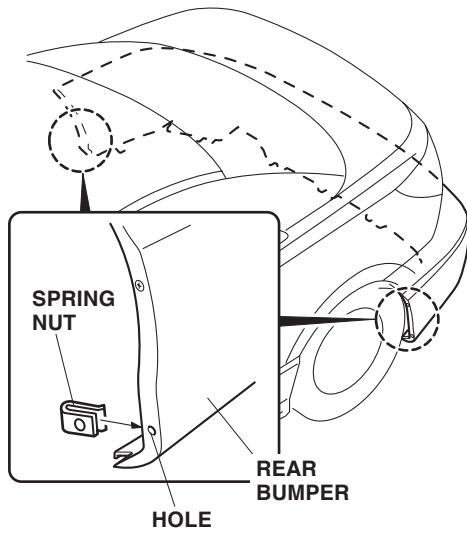

- Attach a strip of masking tape to the end of each adhesive backing, and peel back 1-1/2 to 2 inches of the adhesive backing. Fold the ends back, and tape them to the front of the rear under spoiler.

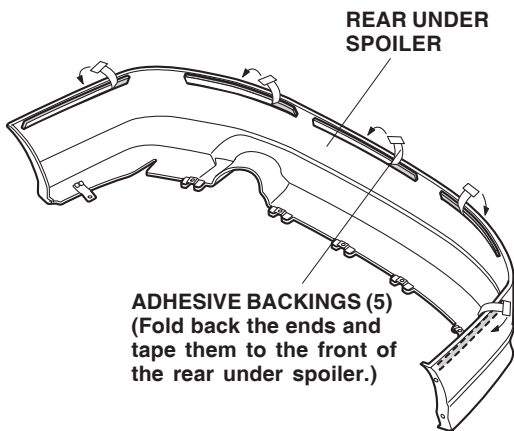

- Using isopropyl alcohol on a shop towel, clean the rear bumper where the rear under spoiler will attach.

- Remove and discard two (four, if equipped with a rear inner fender) self-tapping screws. Position the rear under spoiler on the rear bumper, and install the four self-tapping screws.

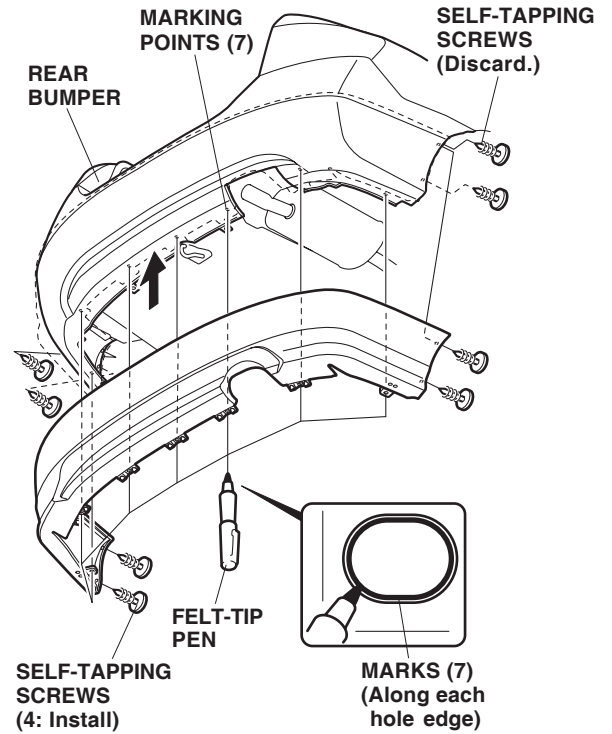

- While holding pressure on the rear under spoiler, use a felt-tip pen to mark the rear bumper along each hole edge in the bracket on the rear under spoiler.

NOTE: If a gap is visible between the rear bumper and under spoiler, remove the rear under spoiler and measure the centerline distance to the edge of the rear bumper and mark as shown.

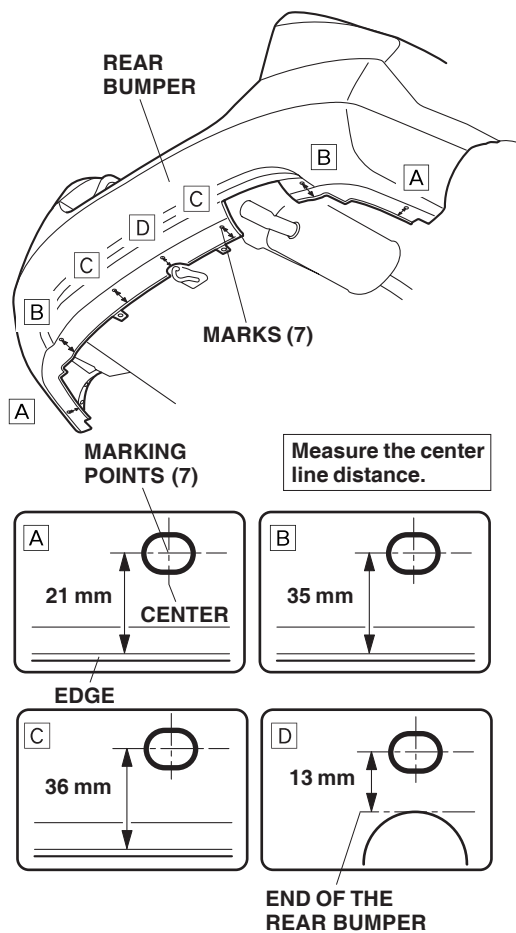

11. Use a push pin to make a hole through each mark you made. While wearing eye protection, drill seven 10 mm holes through the marks.

- Using a drill stop on the end of each bit, first drill with a 3 mm drill bit, and finish with a 10 mm drill bit.
- After drilling, remove any burrs from the edges of the holes with a file.

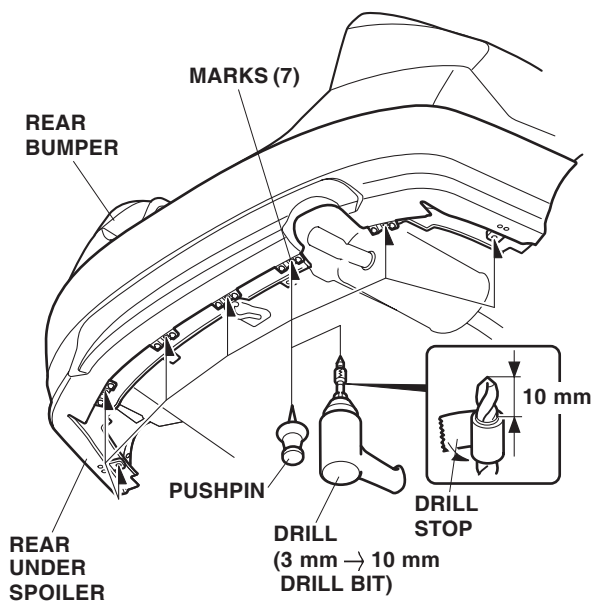

- Remove the two clips from the bottom of the rear bumper.

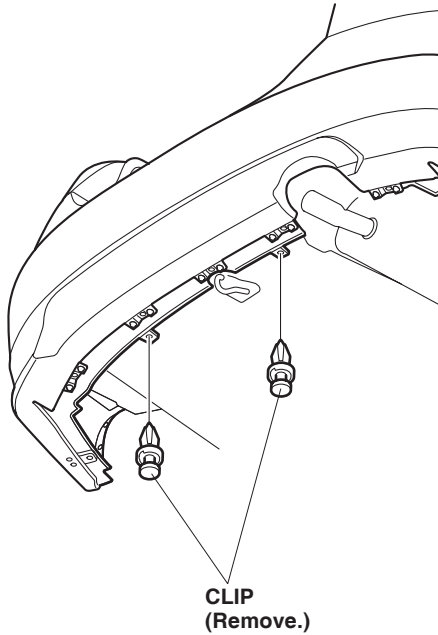

- Position the rear under spoiler on the rear bumper, and install the rear under spoiler with one clip and one rubber washer, and six flange bolts and six flange nuts. Do not tighten the flange bolts and flange nuts yet.

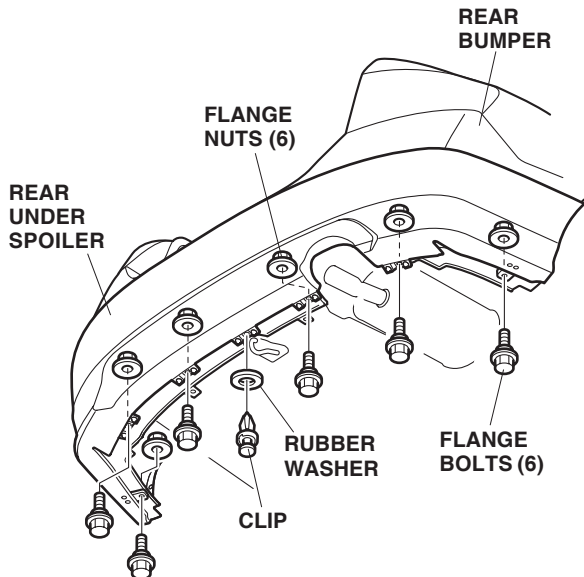

- While applying pressure on the rear under spoiler, carefully remove the adhesive backings in the sequence shown. After removing, hold the rear under spoiler firmly against the rear bumper with the palm of your hand for 30 seconds.

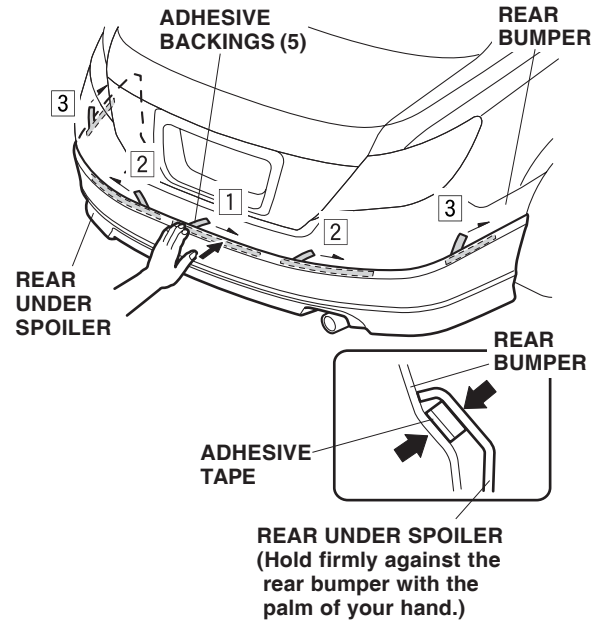

- Tighten the self-tapping screws, flange bolts, and flange nuts temporarily installed in steps 9 and 13.
- Reinstall all removed parts.

Give a copy of this page to your customer.

- When towing the vehicle, follow the instructions described in the vehicle owner's manual.

