



# INSTALLATION INSTRUCTIONS

Accessory

**XM RADIO SYSTEM**

Application

**2006 CIVIC  
2 DOOR (EX, Si)**

Publications No.

**All 30855-31223**

Issue Date

**OCT 2005**

## PARTS LIST

**XM Radio Attachment (Sold Separately):  
P/N 08B15-SNA-100**

Bus cable

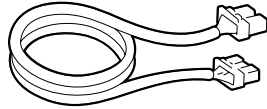

Front bracket

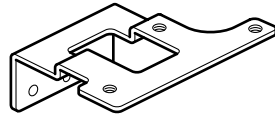

Rear bracket

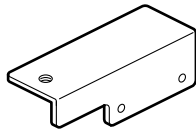

Clip



Double-sided tape



5 Pan screws, 5 x 8 mm



5 Plain washers, 5 mm



3 Flange bolts ,6 x 12 mm



Coupler clip



Cover seal

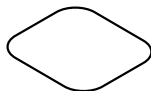

20 Wire ties

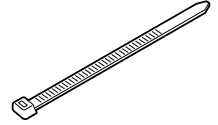

7 Wire tie with clips

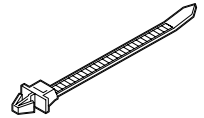

12 Cushion tapes



8 EPT seals

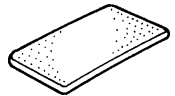

**XM Antenna (sold separately):  
P/N: 08A15-EX5-100B**

Antenna Assy

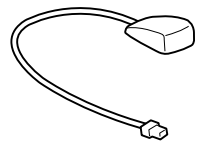

Splitter Assy

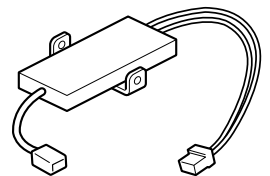

Coupler clip



**Unit kit (sold separately):**  
**P/N 08A15-EX5-000**

XM tuner

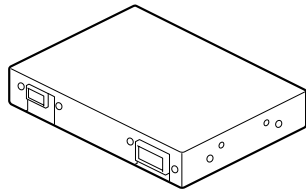

**Bus Cable 2 Port (sold separately):**  
**P/N 08A31-0F1-000**

Bus cable 2 port

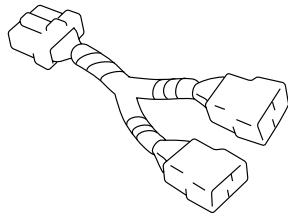

### TOOLS AND SUPPLIES REQUIRED

- #2 Phillips screwdriver
- Flat-tip screwdriver
- Utility knife
- Diagonal cutters
- Tape measure
- Shop towel
- Scissors
- Ratchet
- 8 mm, 10 mm, and 14 mm Socket
- 8 mm, 10 mm, and 14 mm Combination wrenches
- Isopropyl alcohol  
(Isopropyl alcohol, in a 60/40 solution with water)
- Masking tape

**Illustration of the XM Radio System Installed on the Vehicle**

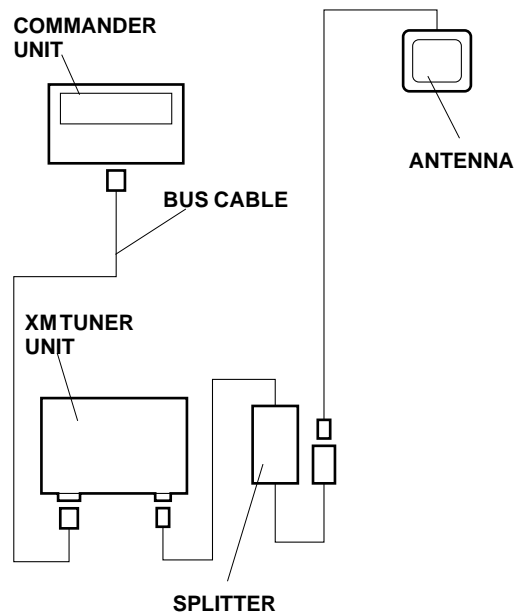
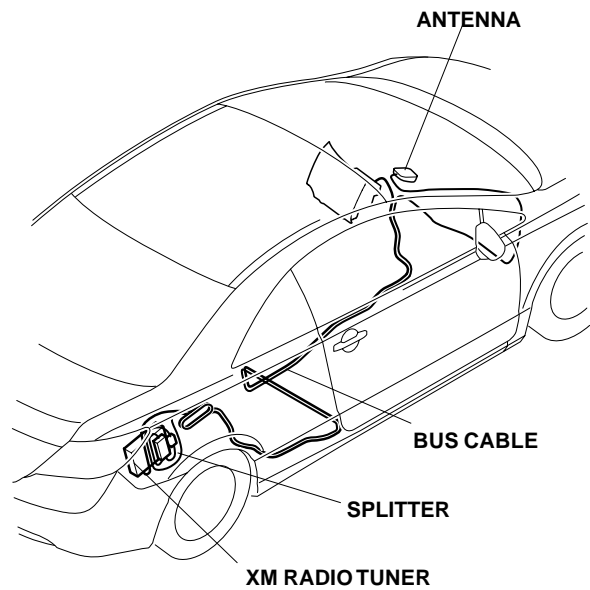

## INSTALLATION

**Customer Information:** The information in this installation instruction is intended for use only by skilled technicians who have the proper tools, equipment, and training to correctly and safely add equipment to your vehicle. These procedures should not be attempted by "do-it-yourselfers."

1. Make sure you have the anti-theft code for the radio, then write down the frequencies for the preset buttons.
2. Disconnect the negative cable from the battery.
3. Remove the passenger's dashboard lower cover (four clips, and two pins).

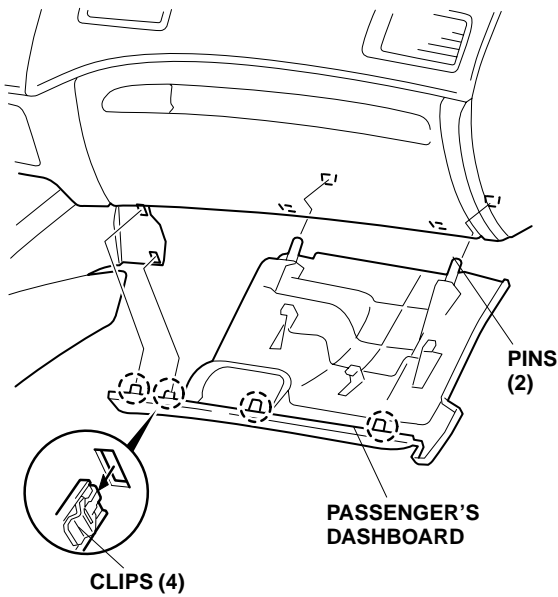

4. Remove the two bolts under the glove box.
5. Open the glove box. Release the stoppers and remove the glove box.

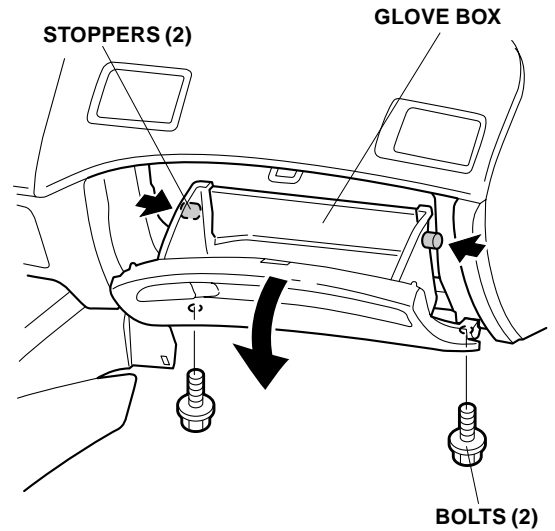

6. Remove the driver's dashboard lower cover (eight clips).

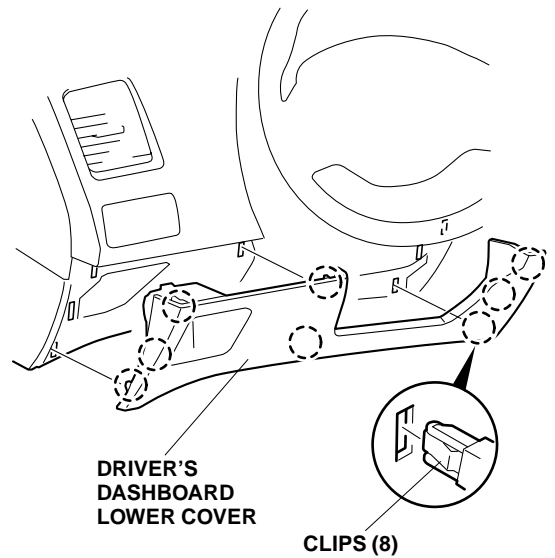

- Remove the inside cover from the front console pocket (two tabs).

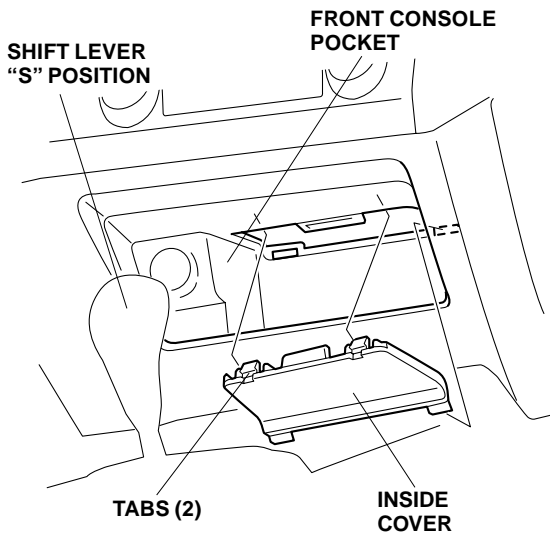

- Lower the steering wheel lever, and pull the steering wheel toward you.

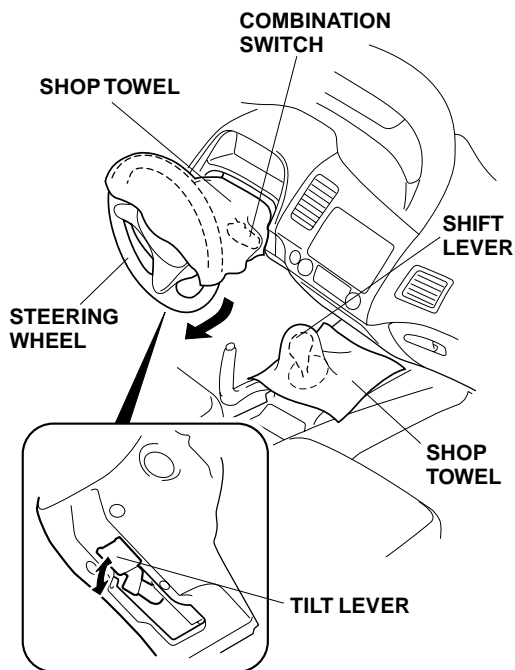

- To protect the dashboard area, place a shop towel over the steering wheel and shift lever.

- Apply masking tape to the meter panel as shown, and remove the instrument panel (one self-tapping screws, 11 clips, and one connector).

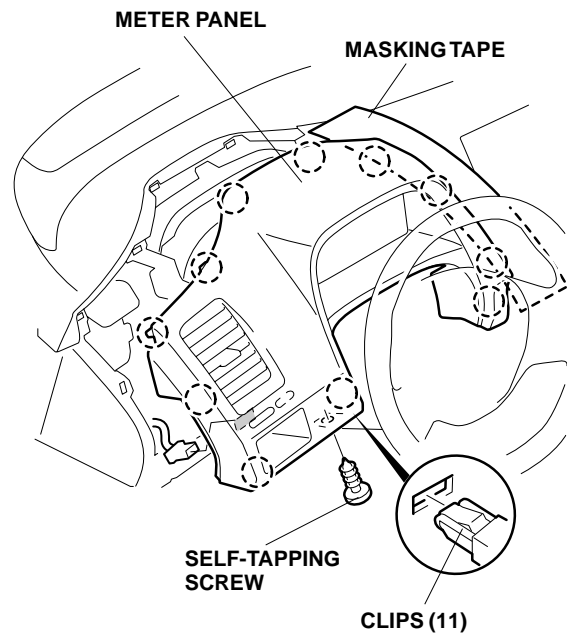

- Apply masking tape to the instrument panel as shown, and remove the center panel (two bolts, ten retaining clips, and unplug the vehicle connectors).

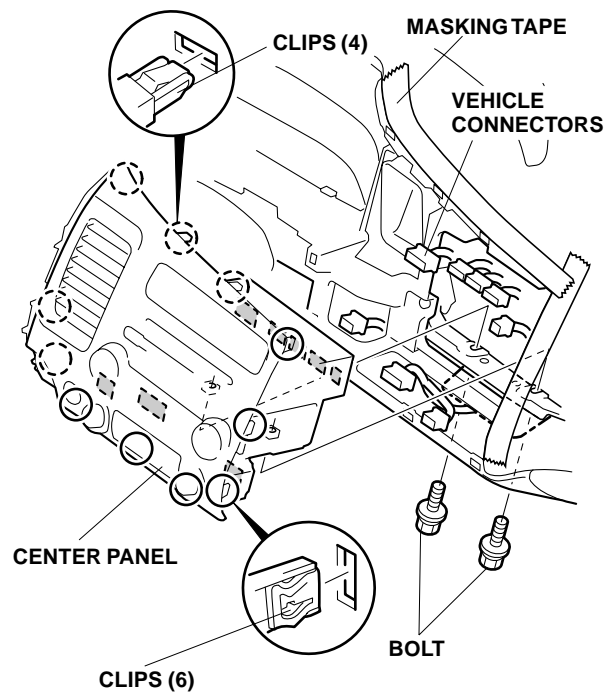

12. Remove the weatherstrip from the opening edge of the right front door in the area shown.

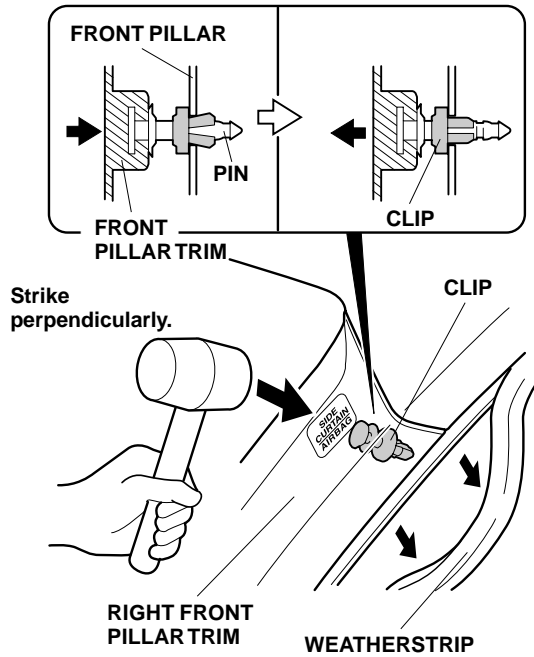

13. Push the clip into the vehicle side by striking the top of the right front pillar trim in the part marked "SIDE CURTAIN AIRBAG" with the rubber mallet perpendicular to the vehicle. Then remove the clip.
14. Remove the weatherstrip in the area shown, and remove the right front pillar trim (two clips).

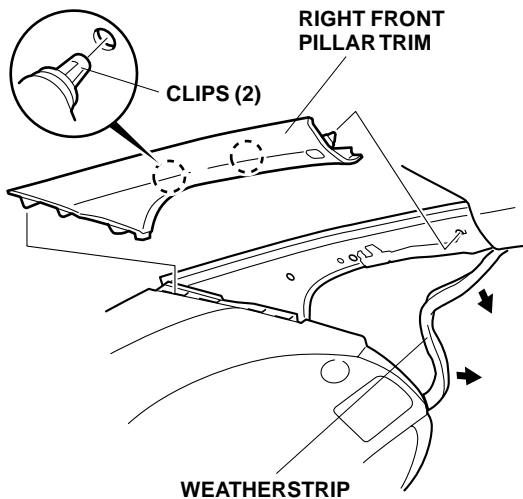

15. Remove the cap from the right sun visor (four retaining tabs).
16. Remove the right sun visor (two T25 Torx screws, and unplug the vehicle connectors).
17. Remove the right and left sun visor holders. Turn the holders 90°, then pull them out.

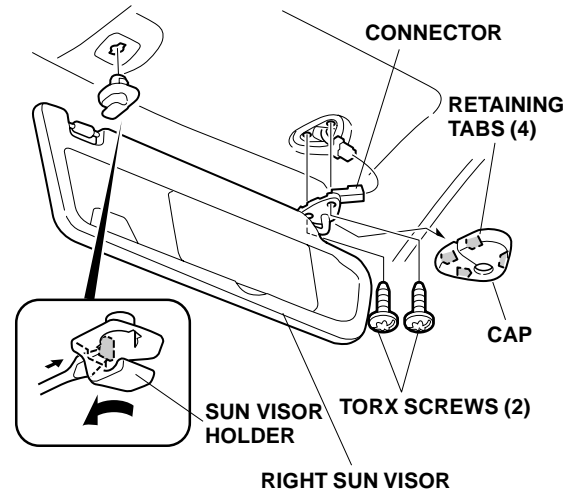

18. Remove the center console cover.

#### A/T Vehicle

- Remove the center console cover (five clips).

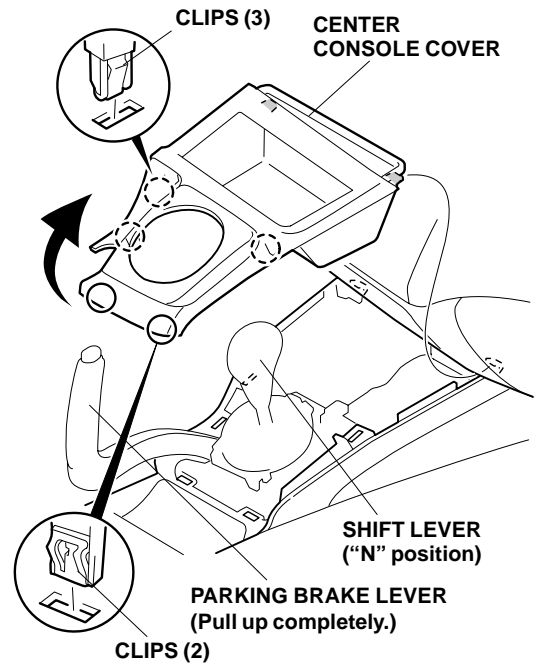

**M/T Vehicle**

- Pull down on the shift boot. Remove the shift knob by turning it counterclockwise.

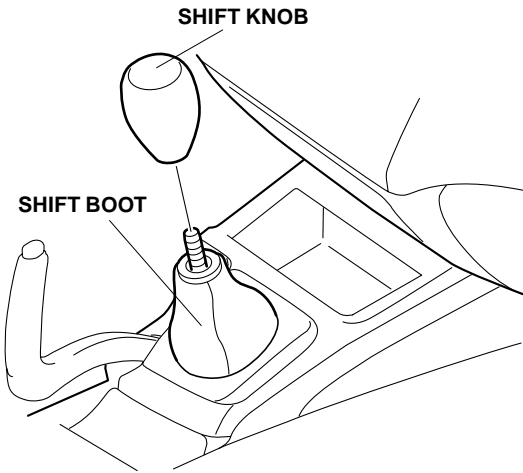

- Remove the center console cover by removing the five clips fastening the center console cover.

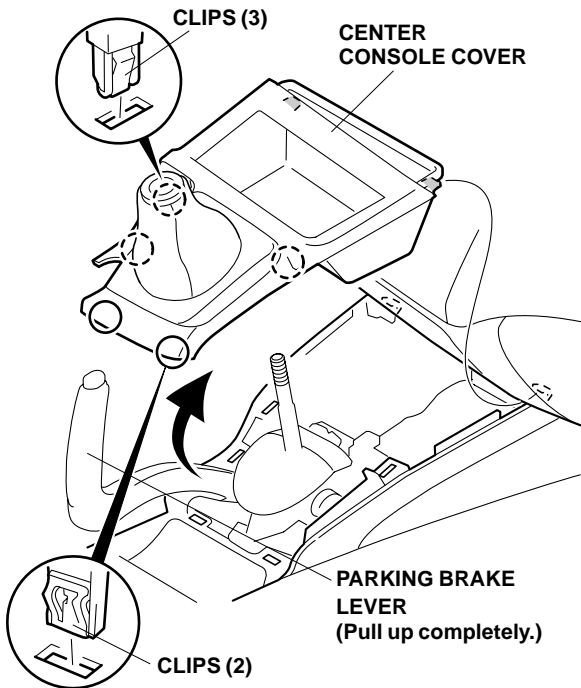

19. Open the center console lid, and remove the mat.

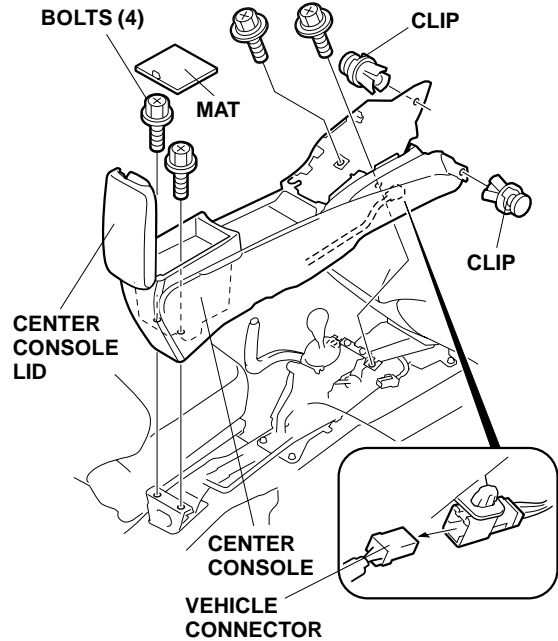

20. Remove the center console (four bolts, two clips, and the vehicle connector).
21. Inside the passenger's compartment area, remove the rear seat cushion by removing the bolt and releasing the two hooks.

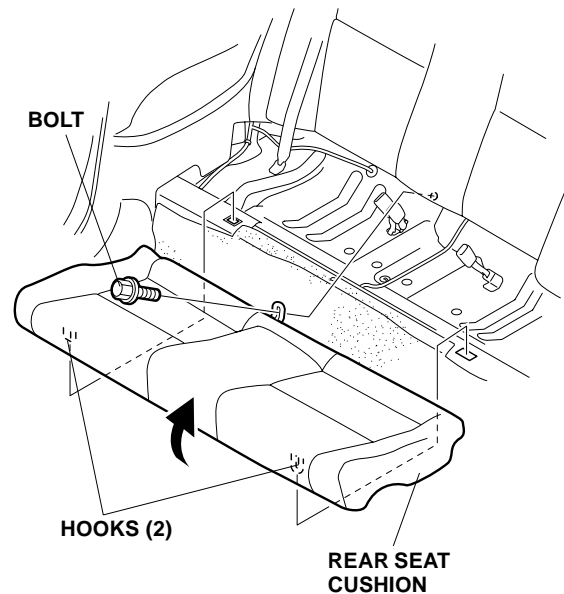

22. Open the trunk lid and fold the rear seat-back forward by pulling the levers under the rear parcel shelf. Remove the trunk floor mat (two clips).

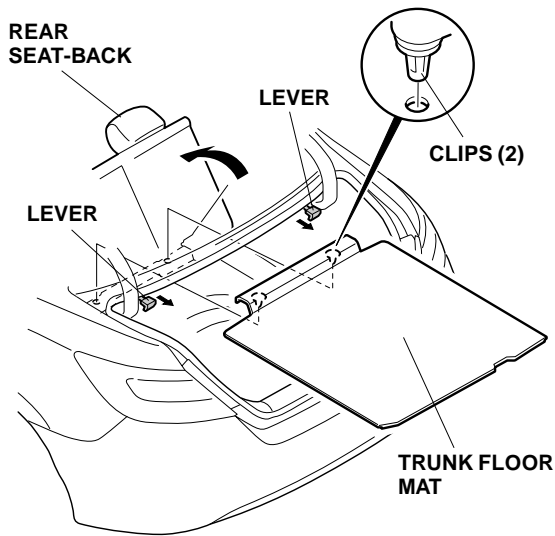

23. Remove the trunk weatherstrip from the edge of the trunk opening in the area shown.

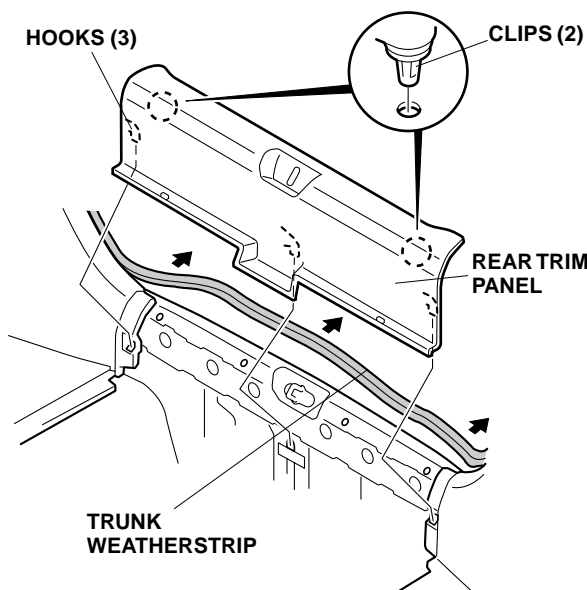

24. Remove the rear trim panel (two clips and three hooks).

25. Continue removing the weatherstrip in the area shown. Remove the five clips, then pull out on the right trunk side trim panel in the direction shown.

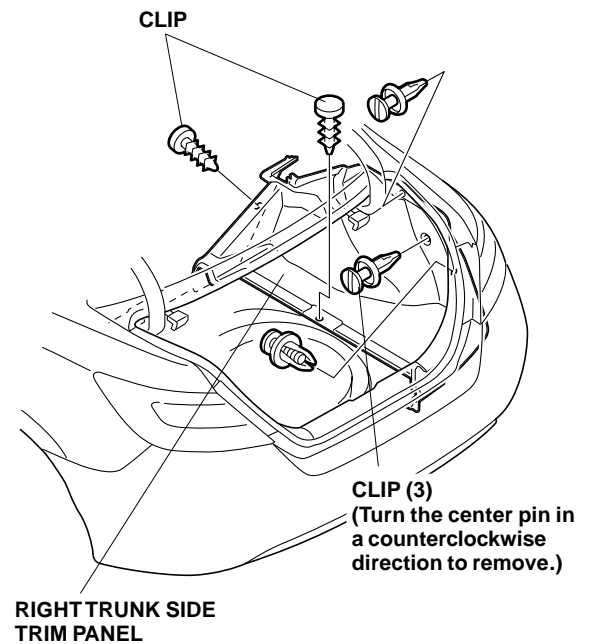

#### Routing the bus cable

26. Route the bus cable from the trunk along the vehicle harness.

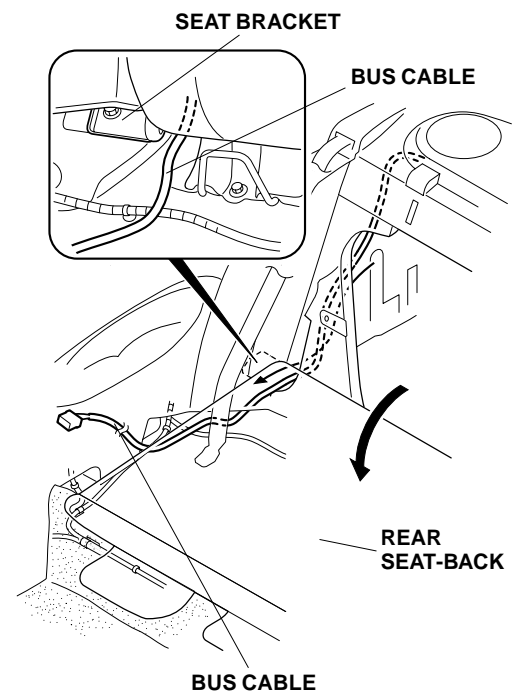

- Lift up and lock the right rear seat-back, then remove the clip that secures the floor carpet. Pull back the floor carpet.

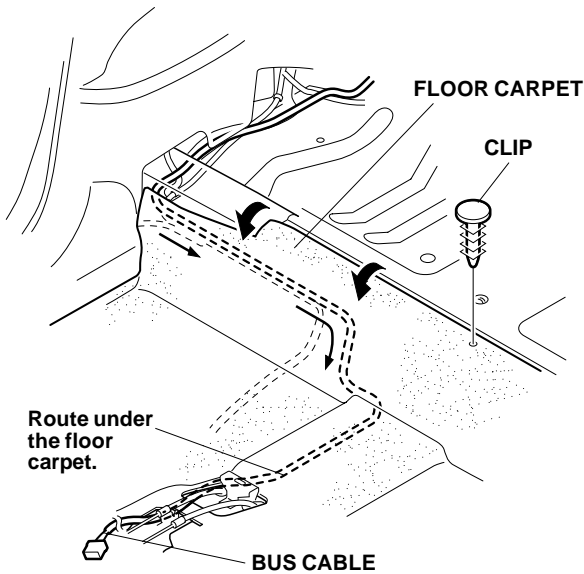

- Route the Bus cable forward to the right front console frame along the vehicle harness.

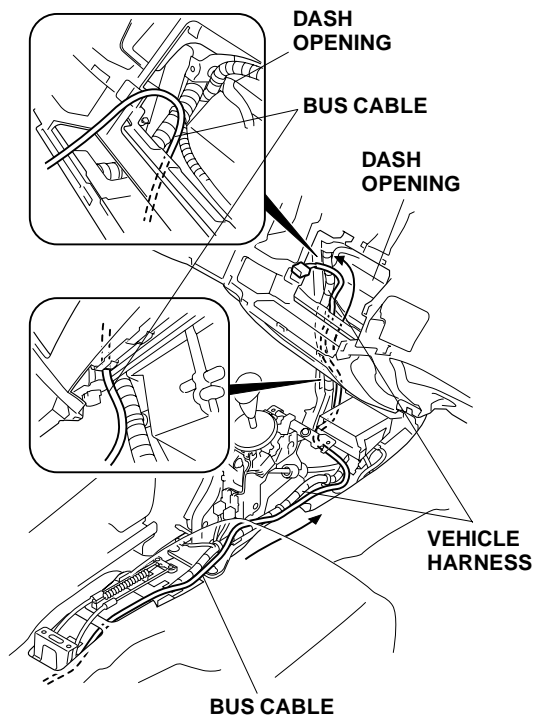

### Routing the antenna cable

- Using isopropyl alcohol on a shop towel, clean the right front upper corner on the inside of the front window.
- Remove the adhesive backing from the antenna, and attach the antenna to the front window at the location shown. Install the antenna by applying sufficient pressure.

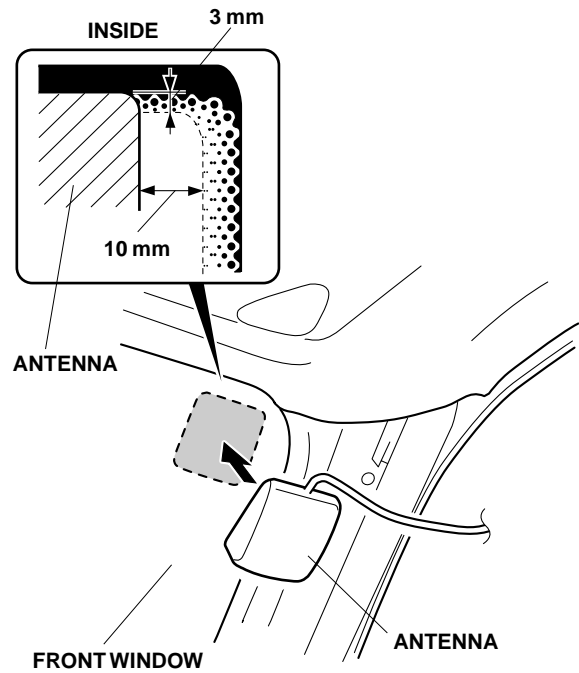



31. Using isopropyl alcohol on a shop towel, clean the right front upper corner on the outside of the front window.

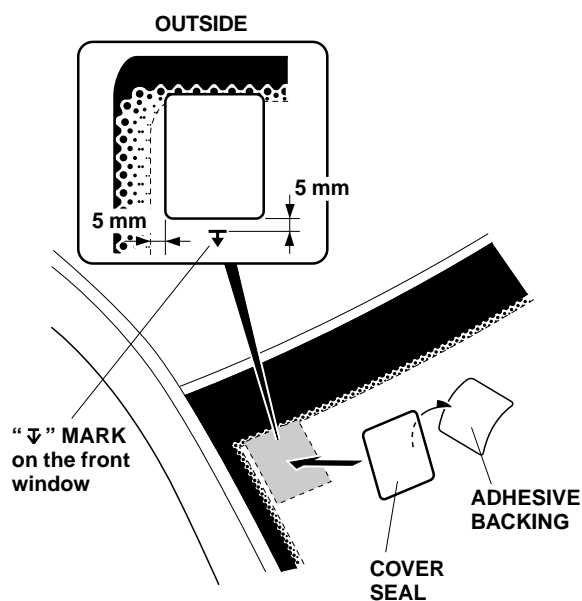

32. Remove the adhesive backing from the cover seal, and attach it to the outside of the front window at the location shown.
33. Using scissors, cut three EPT sealers in half.

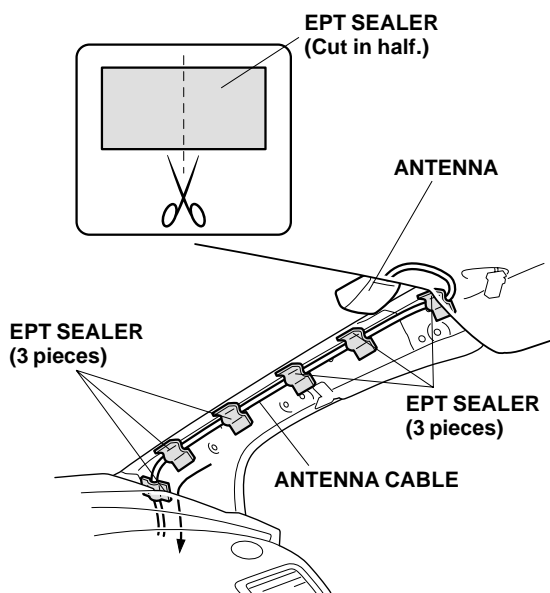

34. Route the antenna cable down the passenger's A-pillar. Attach the antenna cable to the A-pillar panel with the six pieces of cut EPT sealer in the areas shown.

35. Route the antenna cable down behind the dashboard stay and toward the glove box. Secure the antenna cable to the vehicle harness with the three wire ties.

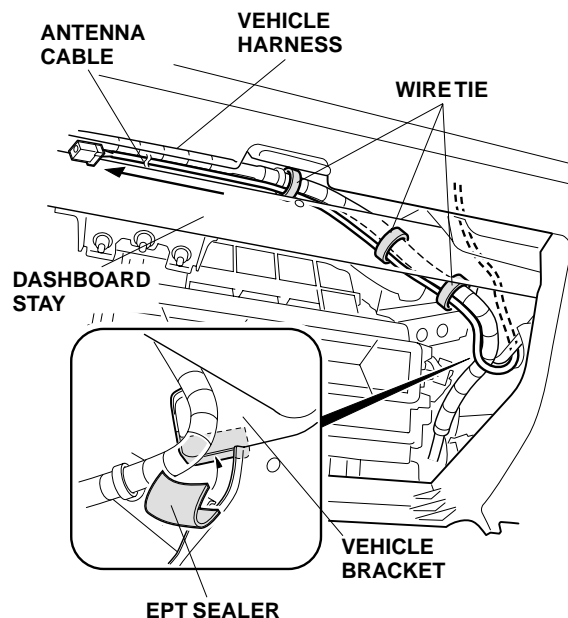

36. Inside the glove box opening, route the antenna cable along the vehicle harness and toward the audio unit opening. Secure the antenna cable to the vehicle harness with the wire tie in area shown.

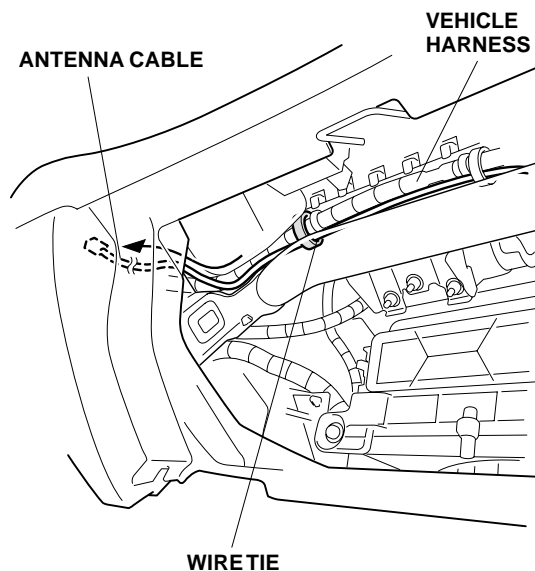

37. Route the antenna cable down along the bus cable as shown.
38. Measure 300 mm from the end of the bus cable connector, then secure the bus cable and antenna cable to the vehicle harness with six wire ties.

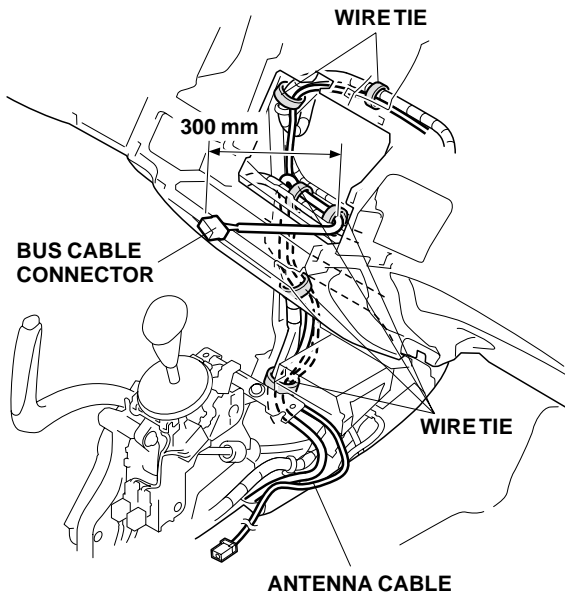

39. Route the antenna cable along the bus cable, secure the bus cable and antenna cable to the vehicle harness with three wire ties.
40. Using isopropyl alcohol on a shop towel, clean the area where the cushion tape will attach. Attach the bus cable and antenna cable to the floor panel with the three cushion tapes in the area shown.

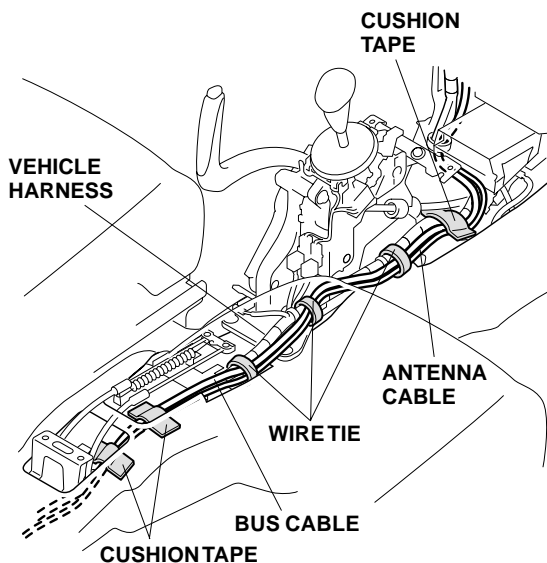

41. Route the antenna cable along the bus cable, turn over the floor carpet, then attach the bus cable and antenna cable to the floor panel with the two cushion tapes in the areas shown.
42. Secure the bus cable and antenna cable to the vehicle harness with the three wire ties in the areas shown.

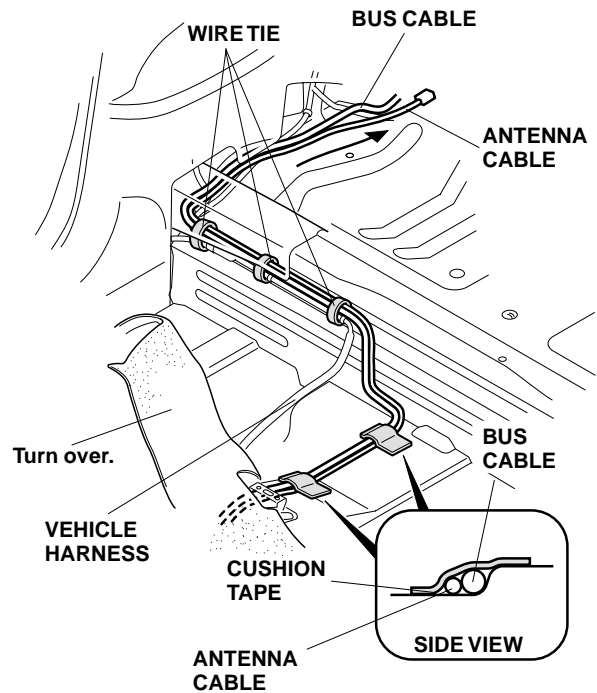

43. Route the antenna cable along the bus cable, secure the bus cable and antenna cable to the vehicle harness with the two wire ties in the areas shown.
44. Attach the bus cable and antenna cable to the floor panel with the four cushion tapes in the areas shown.

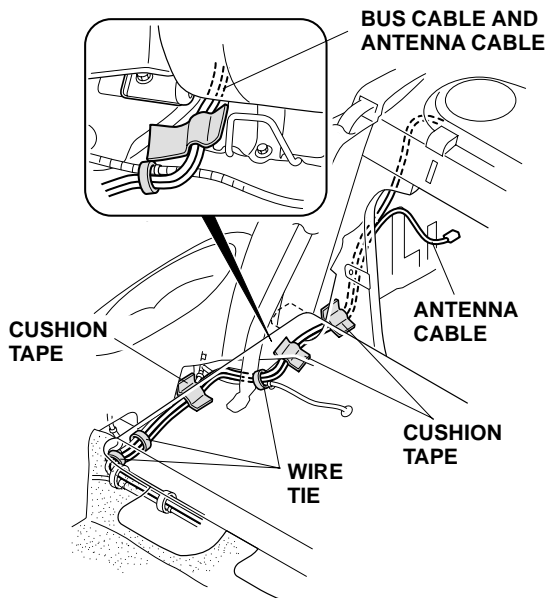

45. Route the bus cable and the antenna cable up on the right trunk inner panel. Loosely secure them to the holes of the panel with the three wire ties with clip.

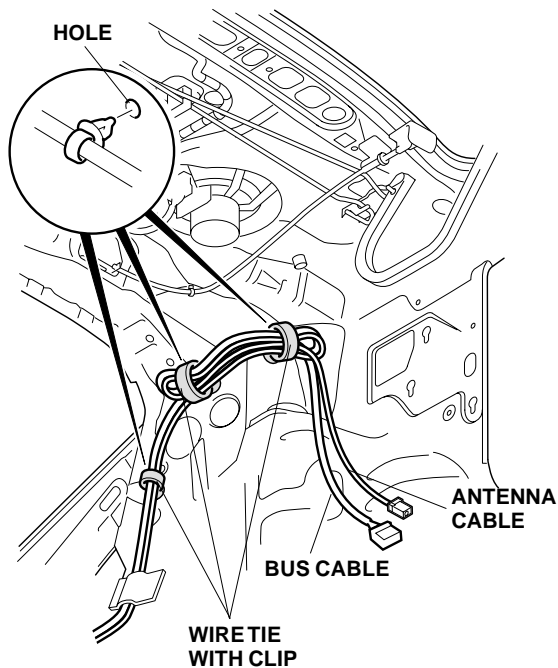

### Installing the XM tuner unit

46. Install the front and rear brackets to the XM tuner with four 5 x 8 mm washer screws.

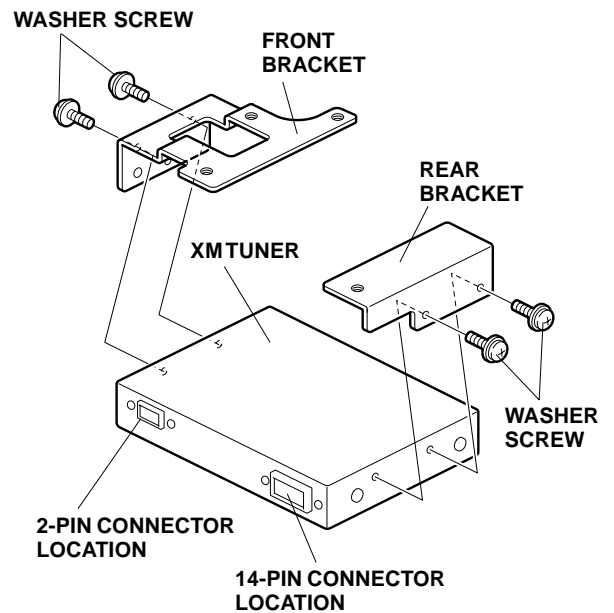

47. Using isopropyl alcohol on a shop towel, clean the XM tuner where the splitter will attach. Remove the adhesive backings from the double-sided tape, and install the splitter to the XM tuner with the double-sided tape at the location shown. Secure the splitter to the front bracket with one 5 x 8 mm washer screw.

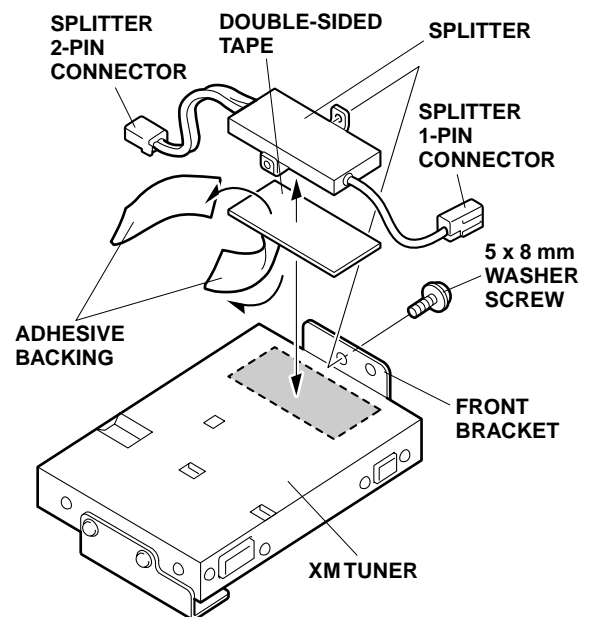

48. Plug the splitter 2-pin connector into the XM tuner.
49. Install the connector clip to the splitter 1-pin connector, then insert it into the front bracket hole in the area shown.

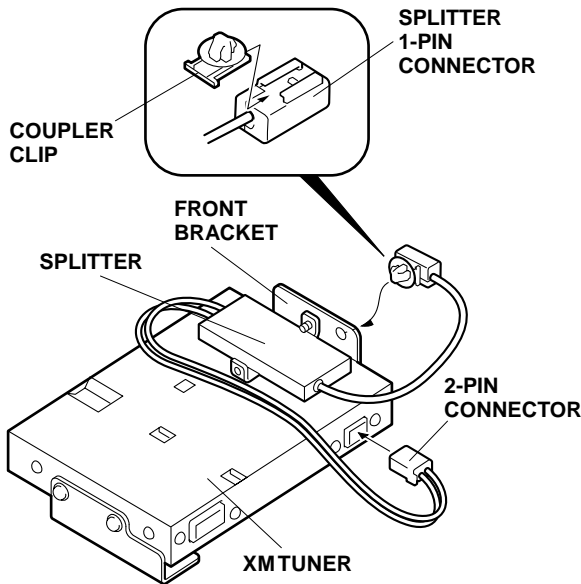

50. Using isopropyl alcohol on a shop towel, clean the right trunk inner panel where the EPT sealers will attach, and attach them to the right trunk inner panel at the location shown.

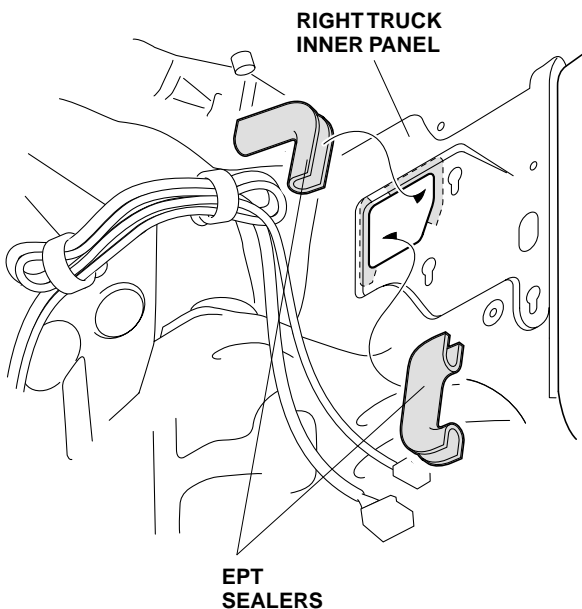

51. Route the bus cable and the antenna cable through the hole of the right trunk inner panel.
52. Plug the bus cable connector into the XM tuner and the antenna cable connector to the splitter 1-pin connector.

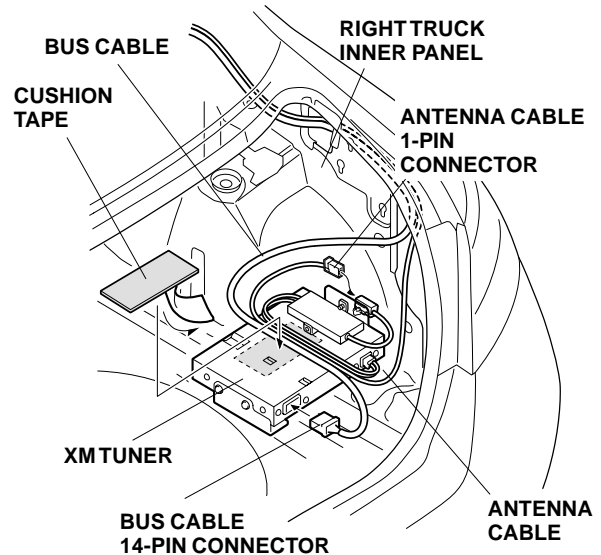

53. Attach the antenna cable on the XM tuner with the cushion tape in the area shown.
54. Loosely attach two 6 x 12 mm flange bolts to the front and rear brackets as shown.

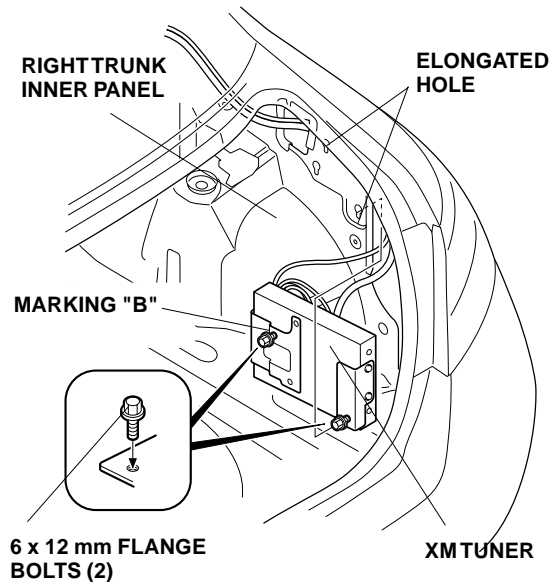

55. Place the XM radio assembly to back of the right trunk inner panel. Set the two 6 x 12 mm flange bolts into the elongated holes in the body panel. Tighten the two 6 x 12 mm flange bolts.

56. Fold the excess bus cable and antenna cable, and secure them with the two wire ties with clip installed in step 46.

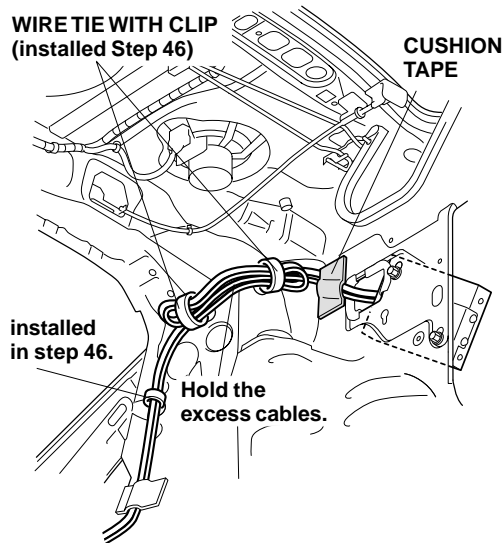

57. Secure the bus cable and the antenna cable on the right trunk inner panel with the cushion tape.

***If the vehicle you're working on is equipped with CD Changer, go to step 59; otherwise, continue with step 61.***

58. Plug in the bus cable 2 port connectors the two BUS cables.

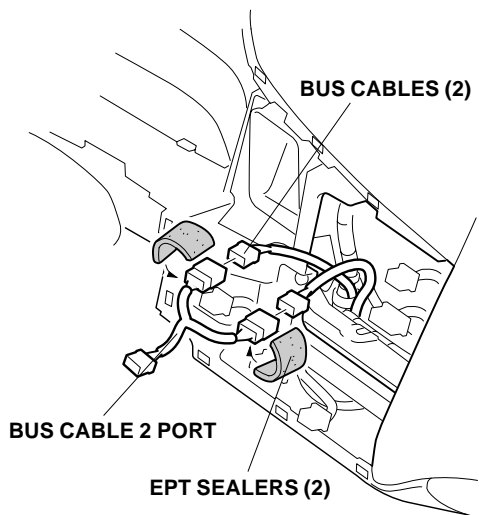

59. Wrap the two plugged connectors with the two EPT sealers respectively.

60. Plug the bus cable connector into the rear of the audio unit.

#### Standard Audio Unit

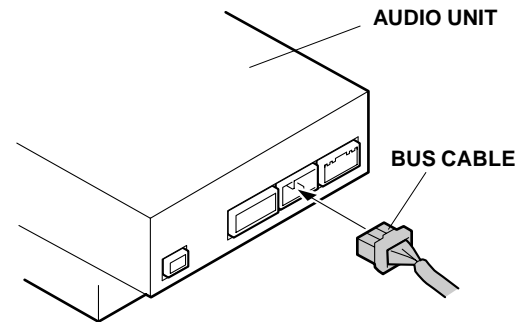

61. Connect the vehicle connectors to the center panel, and reinstall the center panel.

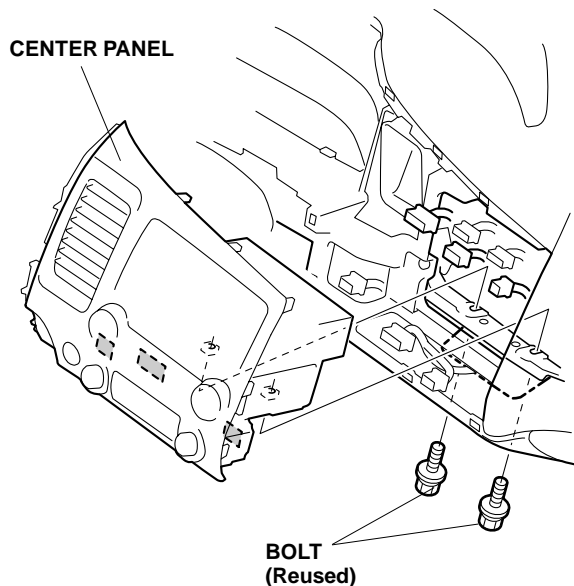

62. Exchange the old clip to a new one on the right front pillar trim.

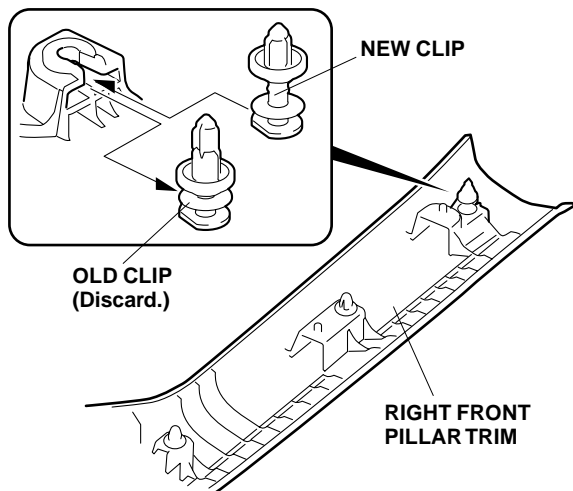

63. Check that all wire harnesses are routed properly and all connectors are plugged in.
64. Reconnect the negative cable to the battery.
65. Enter the customer's radio anti-theft code, and reset the radio station presets.
66. Set the clock.
67. Check the operation of the XM radio system according to the vehicle's Owner's Manual supplied.
68. Reinstall all removed parts.

**NOTE:** When the battery is disconnected, the driver's window AUTO function is disabled.

- Start the engine. Push down on the driver's window switch until the window is fully open.
- Pull up on the driver's window switch to close the window completely, then hold the switch for 2 seconds or more.
- Lower and raise the driver's window to check operation of the driver's window AUTO function.