



INSTALLATION INSTRUCTIONS

Accessory	Application	Publications No.
XM RADIO INTERFACE	2006 CR-V	All 30528
		Issue Date
		SEP 2005

PARTS LIST

**XM Radio Unit Kit (sold separately):
P/N 08A15-EX5-000**

XM Radio unit

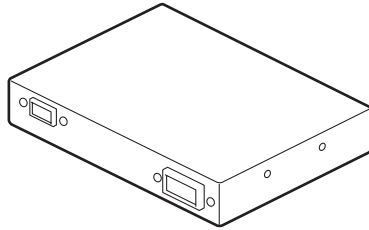

**XM Radio Antenna Kit (sold separately):
P/N 08A15-EX5-100A**

XM Radio antenna

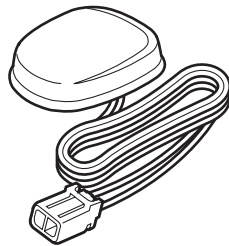

**XM Radio Attachment Kit (sold separately):
P/N 08B15-S9A-100**

XM Radio bracket A

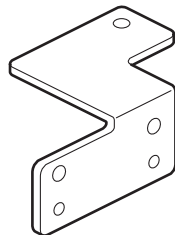

XM Radio bracket B

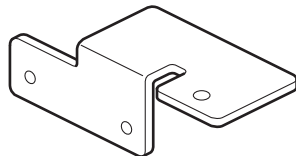

Wire tie

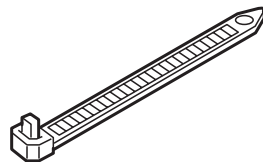

2 Wire tie with clips

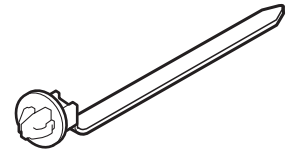

EPT sealer

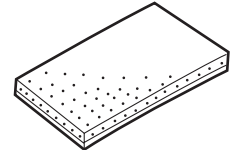

2 Washer-bolt, 6 x 12 mm

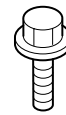

7 Cushion tapes

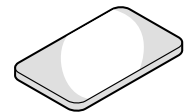

4 Screws, 5 x 8 mm



4 Washers



TOOL AND SUPPLIES REQUIRED

- Phillips screwdriver
- Flat-tip screwdriver
- Isopropyl alcohol
- Shop towel
- 10 mm Combination wrench
- Clip remover
- Diagonal cutters
- Ratchet wrench
- 10 mm and 14 mm socket
- Scissors

Illustration of the XM Radio System Installed on the Vehicle

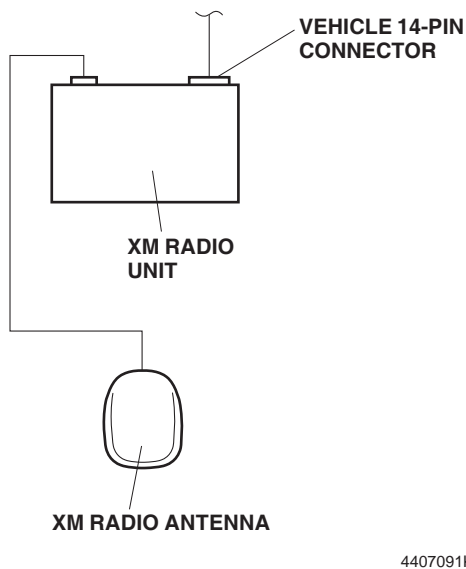
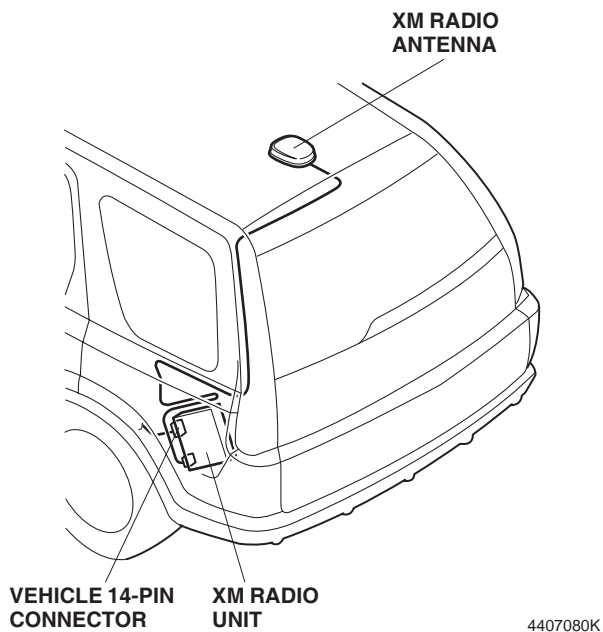

INSTALLATION

Customer Information: The information in this installation instruction is intended for use only by skilled technicians who have the proper tools, equipment, and training to correctly and safely add equipment to your vehicle. These procedures should not be attempted by "do-it-yourselfers."

1. Make sure you have the anti-theft code for the radio, then write down the radio station presets.
2. Disconnect the negative cable from the battery.
3. Open the tailgate.

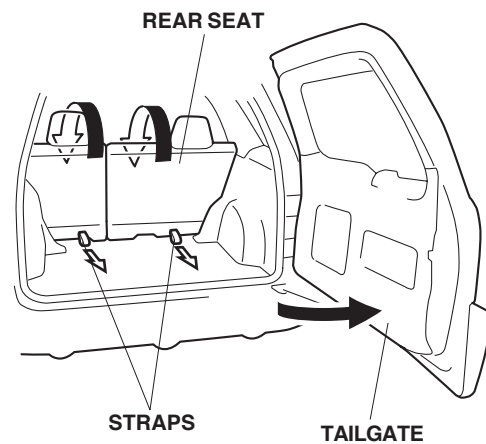

4. Fold down the rear seat-back, then fold the rear seat assemblies forward.

5. Fold the cargo area mat forward, and remove the cargo area floor. Remove the cargo storage bin.

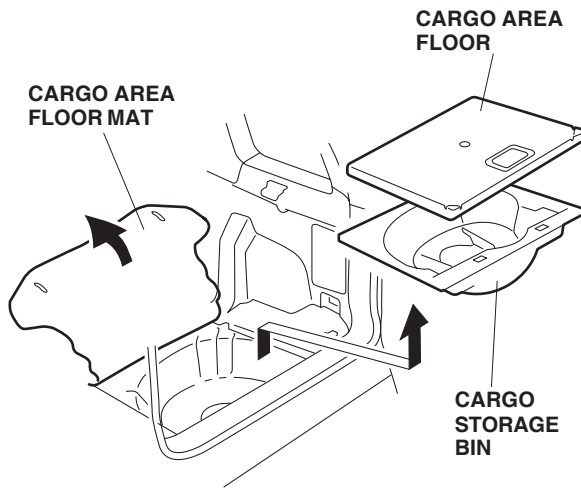

6. Remove the two front clips from the rear trim panel. Pull up on the rear trim panel to release the five clips.

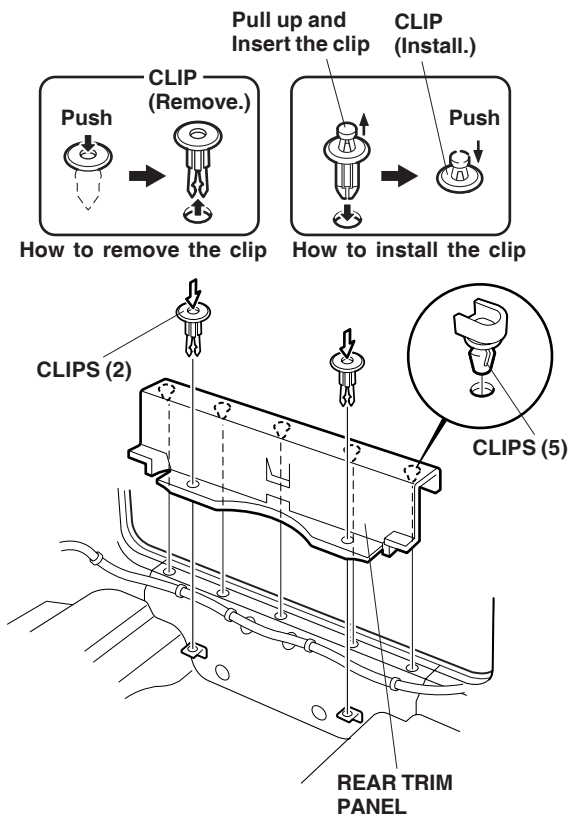

7. Remove the left rear door sill trim (three clips).

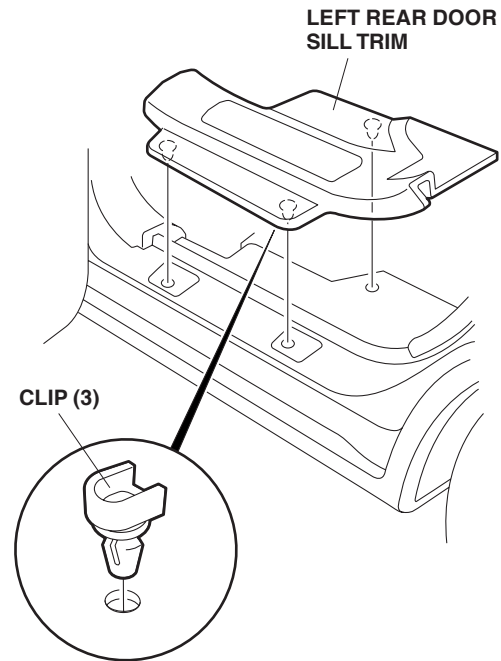

8. Release the two retaining tabs, then pull the accessory socket. Disconnect the vehicle connector from the accessory socket, then remove the accessory socket.

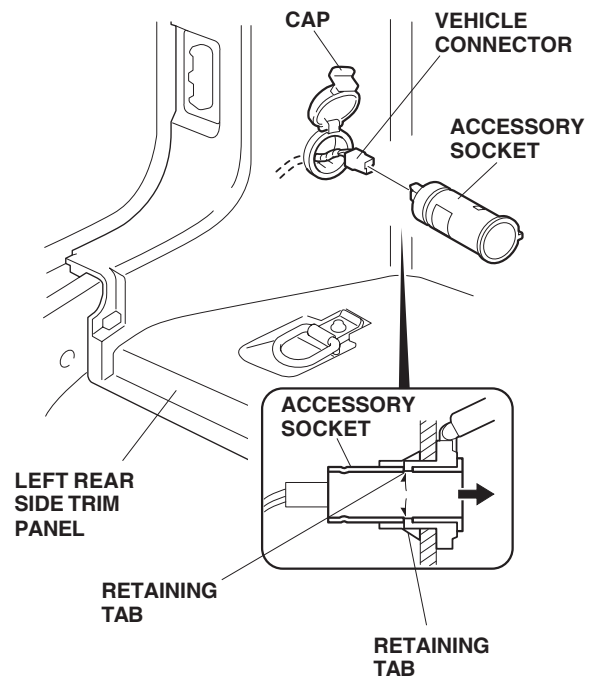

- Remove the bolt that secures the tie-down hook to the left rear side trim panel, and remove the tie-down hook. Open the cap, then remove the self-tapping screw that secures the hook. Remove each hook.

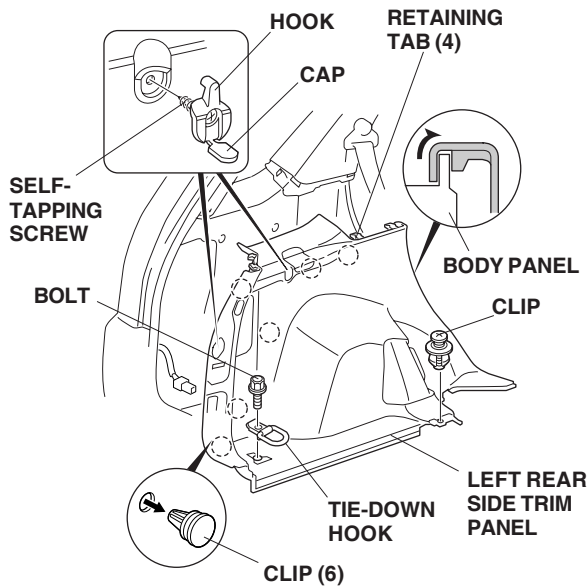

- Remove the clip, and remove the left rear side trim panel from the body panel by starting at the front. Then, release the six clips and four retaining tabs by pulling the left rear side trim panel toward you.

- Remove the left rear pillar upper trim (five clips).

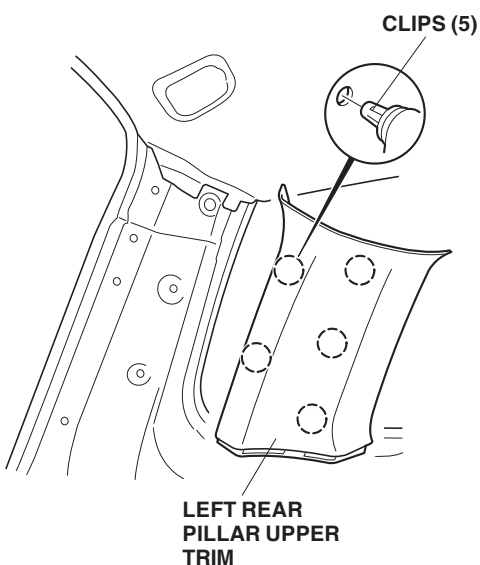

- Gently pull up the panel seal. Take care not to damage the side seal.

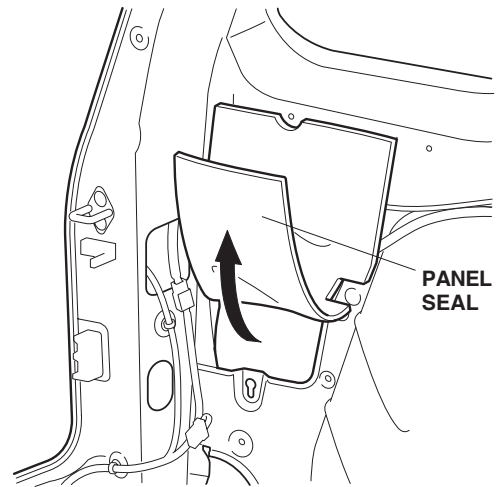

- In the cargo area, remove the rear headliner clip by releasing the two retaining tabs.

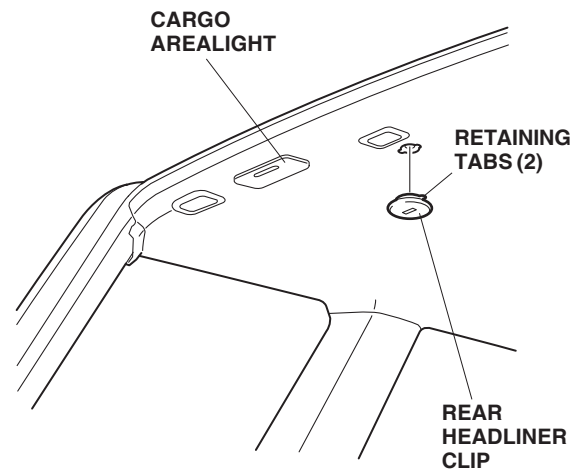

- Through the rear headliner clip hole, remove the nut that secures the roof cover. Discard the roof cover, and save the nut to be reused later.

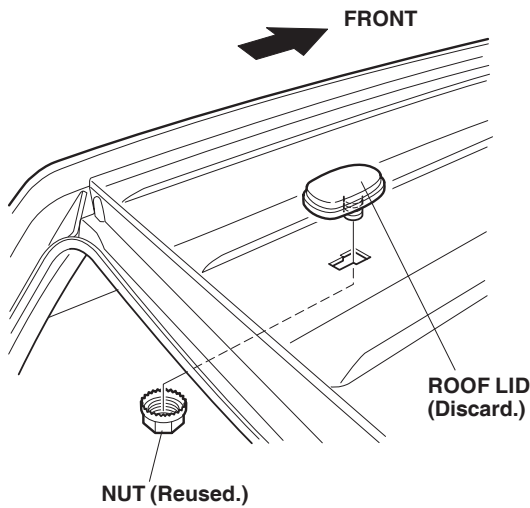

- Remove the cargo area light:
 - Release the four retaining tabs, then remove the lens.
 - Remove the two screws that fasten the cargo arealight, and unplug the vehicle connector. Remove the cargo arealight.

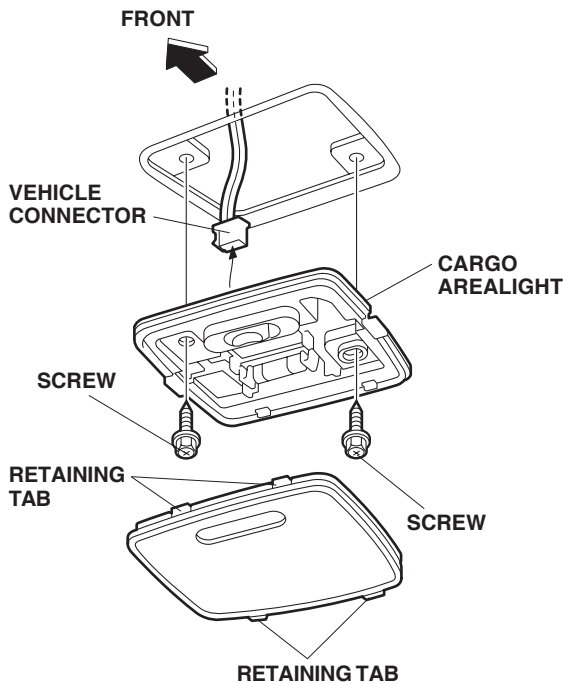

- Gently pull down the headliner to release the one headliner clip. Be careful not to bend the headliner.

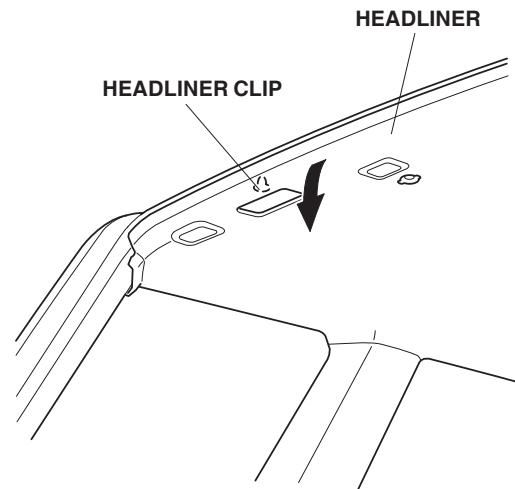

Installing the XM Radio Unit

- Install the XM radio bracket A and bracket B to the XM radio unit using the four 5 x 8 mm screws and four washers provided.

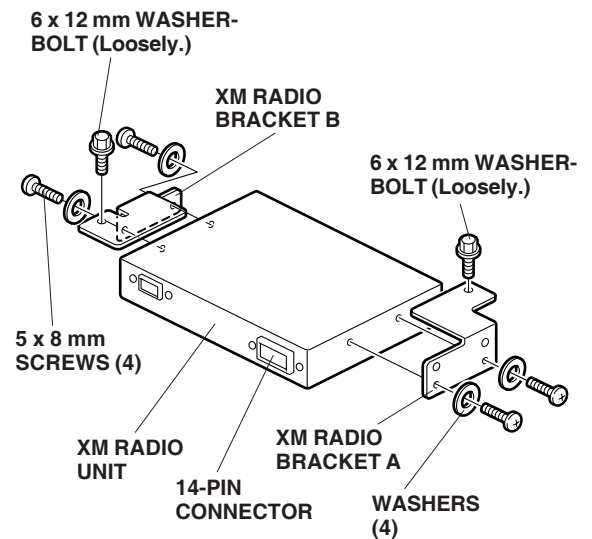

- Loosely attach one 6 x 12 mm washer-bolt to the top of the XM radio bracket A and bracket B.

- Route the XM radio assembly in back of the fuel lid opener cable and the drain tub, and place the XM radio assembly into the body panel. Set the two 6 x 12 mm washer-bolts into the elongated holes in the body panel. Tighten the two 6 x 12 mm washer-bolts.

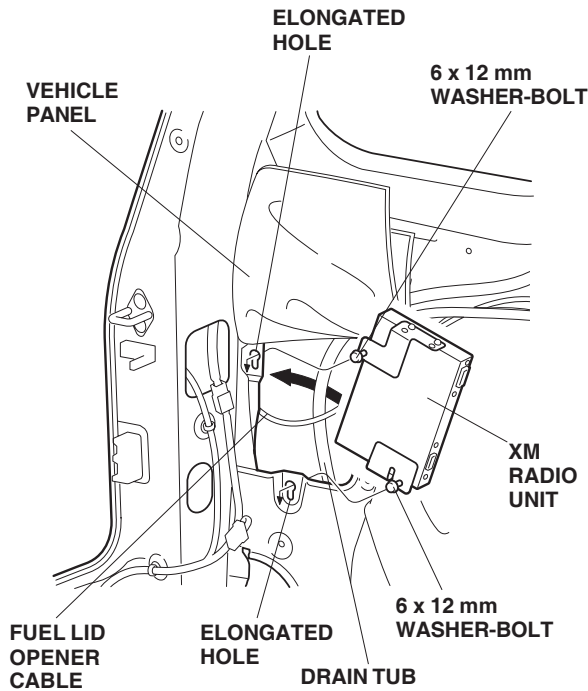

- Locate the vehicle 14-pin connector taped the body panel, and remove the cushion tape to the free connector. Plug the vehicle 14-pin connector into the XM radio unit.

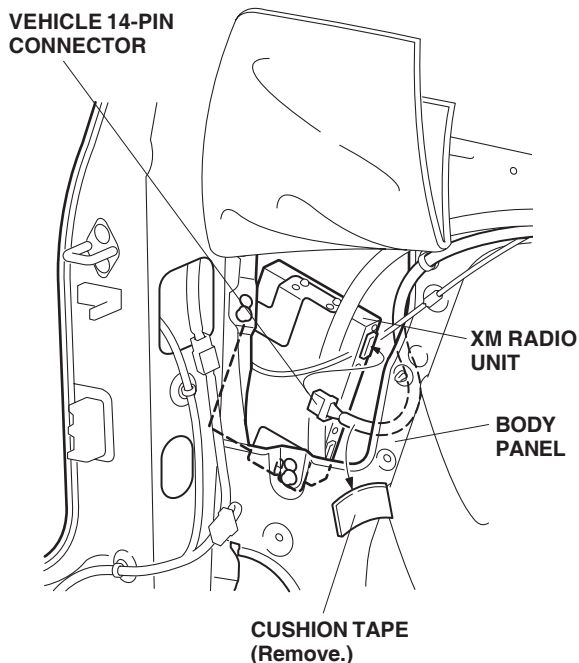

Installing the XM Radio Antenna

- Insert the XM radio antenna connector through the hole of the roof panel, and route the XM radio antenna connector out the back of the roofliner. Position XM radio antenna onto the roof panel. Be careful not to bend the headliner.

NOTE: If the stud-bolt from the XM radio antenna interferes with the inner panel between the roof panel and headliner, push the inner panel forward to install the XM radio. If the stud-bolt interferes with the inner panel even though the panel is pushed forward, slit the inner panel, and install the XM radio antenna.

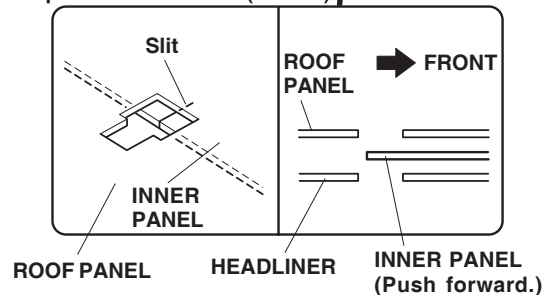
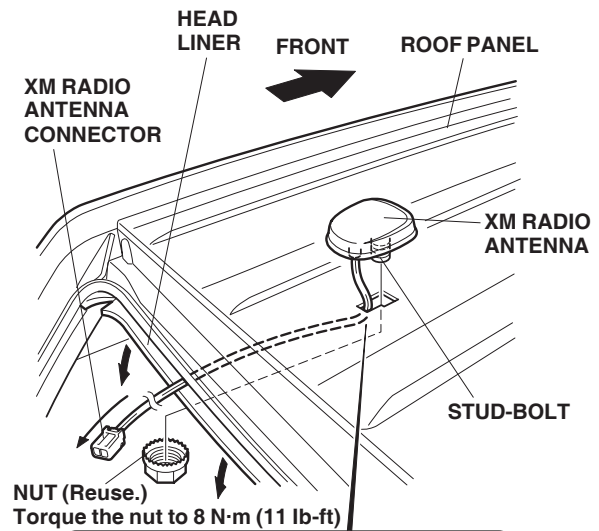

- Use the nut removed in step 14, and install the nut onto the XM radio antenna. Torque the nut to 8 N·m (11 lb-ft). Be careful not to pinch the XM radio antenna cable.

- Route the XM radio antenna cable under the headliner as shown. Be careful not to bend the headliner.

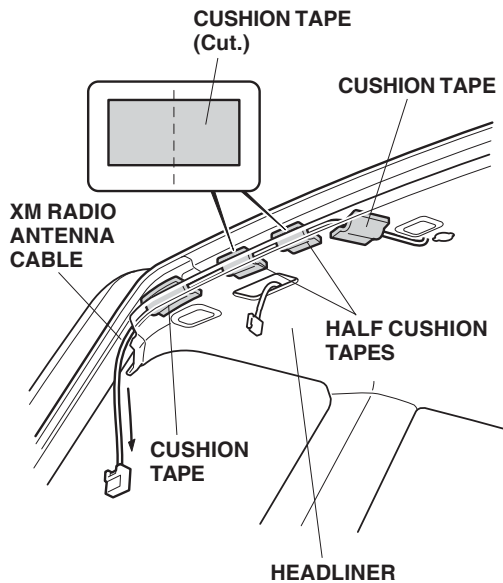

- Using scissors, cut one cushion tape in half.
- Using isopropyl alcohol on a shop towel, clean the area where the cushion tapes will attach. Secure the XM radio antenna cable to the roof panel with two half pieces of cushion tape, and two full cushion tapes.

- Continue to route the XM radio antenna cable down the body panel to the XM radio unit.

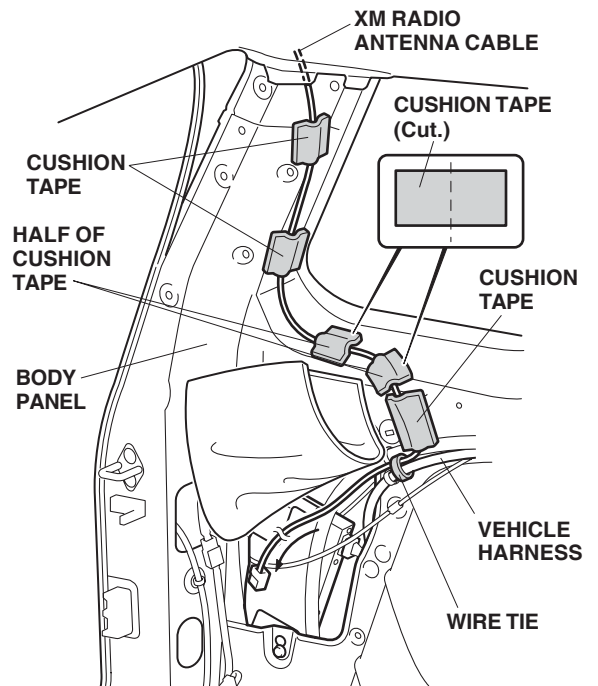

- Using scissors, cut one cushion tape in half.
- Using isopropyl alcohol on a shop towel, clean the area where the cushion tapes will attach. Secure the XM radio antenna cable to the body panel and the harness with two half pieces of cushion tape, three full cushion tapes, and one wire tie.

29. Plug the XM radio antenna connector into the XM radio unit.

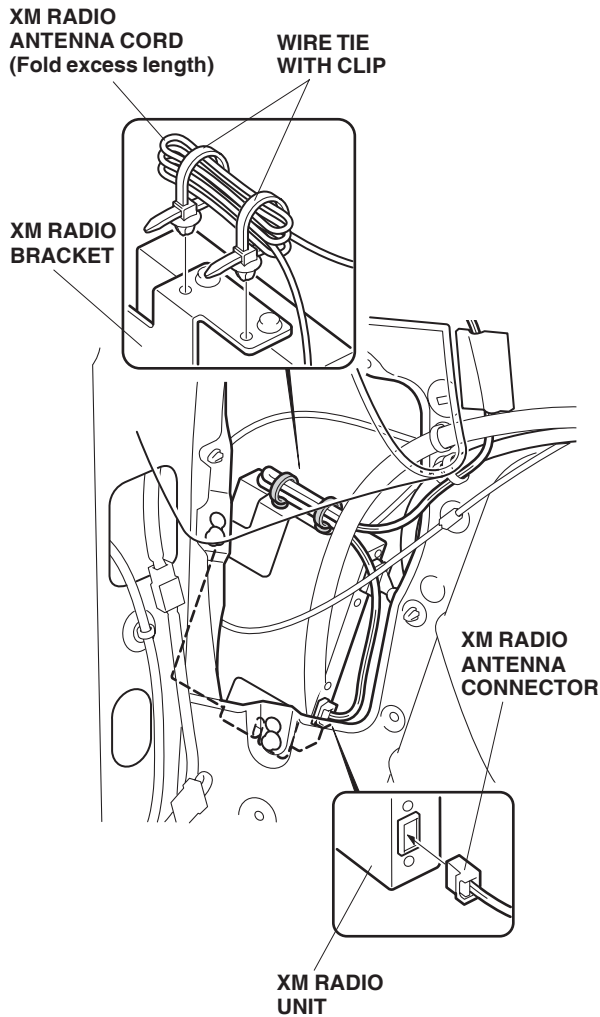

30. Fold the excess length of the XM radio antenna cable, and secure the cable with two wire tie with clips. Attach the wire tie with clips into the holes of the XM radio bracket.

31. Using isopropyl alcohol on a shop towel, clean the area where the EPT sealers will attach.

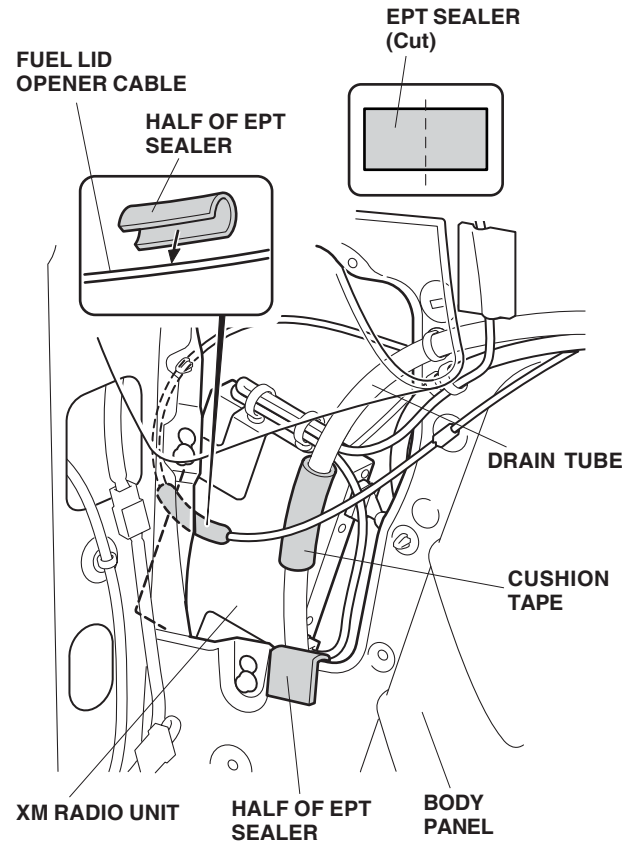

32. Using scissors, cut the EPT sealer tape in half.
33. Wrap one half of the EPT sealer around the fuel lid opener cable and one cushion tape on the tube at the point where the cable and tube touches the XM radio unit.
34. Attach the other half of the EPT sealer to the body panel at the point where the drain tube touch the body panel.

35. Using scissors, cut one cushion tape in half. Using isopropyl alcohol on a shop towel, clean the area where the cushion tape will attach.

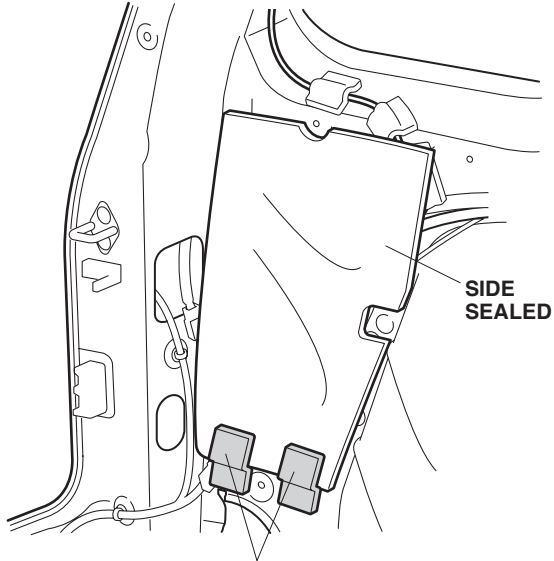

36. Reinstall the panel seal. Secure the bottom of the panel seal with two pieces of cushion tape.
37. Reinstall all removed parts. Check that all clips and fasteners are installed securely.
38. Reconnect the negative cable to the battery.
39. Enter the customer's radio anti-theft code, and reset the radio station presets.
40. Reset the clock.
41. Check the operation of the XM radio system according to the vehicle's Owner's Manual supplied.

NOTE: Whenever the battery is disconnected, the driver's AUTO function is disabled.

42. Start the engine. Push down on the driver's window switch until the window is fully open.
43. Pull up on the driver's window switch fully to close the window completely, then hold the switch for 2 seconds or more.
44. Test the window AUTO function.