

# INSTALLATION INSTRUCTIONS

Accessory	Application	Publications No.
<b>TRAILER HITCH</b>	<b>2006 CR-V</b>	<b>All 30542</b>
		Issue Date <b>SEP 2005</b>

## PARTS LIST

**Trailer Hitch Kit**  
**P/N 08L92-S9A-100**

Trailer hitch

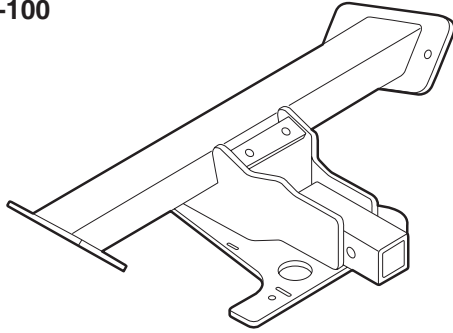

Right bracket

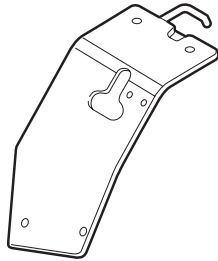

Left bracket

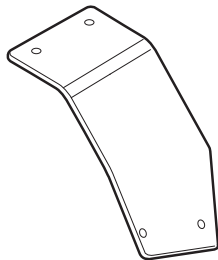

Right upper plate

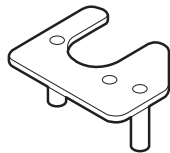

Left upper plate

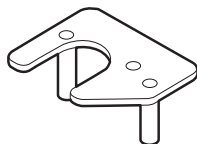

Ball mount

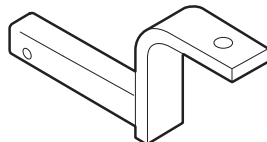

Exhaust rod

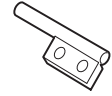

4 Bolts, 10 x 100 mm



4 Nuts, 10 mm



4 Washers, 10 mm



4 Spring washers, 10 mm



4 Bolts, 12 x 35 mm



4 Nuts, 12 mm



8 Washers, 12 mm



4 Spring washers, 12 mm



2 Bolts, 6 x 25 mm



2 Nuts, 6 mm



4 Washers, 6 mm



2 Spring washers, 6 mm



2 Bolts, 8 x 30 mm



2 Nuts, 8 mm



4 Washers, 8 mm



2 Spring washers, 8 mm



Retaining pin

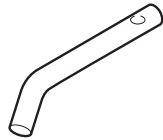

Retaining pin clip



Center bracket

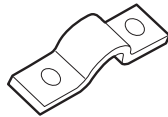

Receiver cover

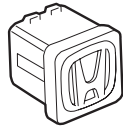

**Trailer Harness Kit (sold separately)  
P/N 08L92-S0X-100R1**

Optional harness

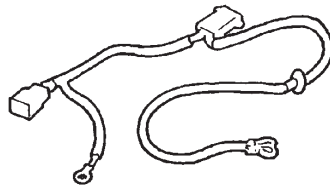

3 Wire ties

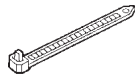

3 Cushion tapes (2 not used)

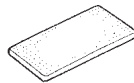

6 Bolts, 12 mm (not used)



6 Flat washers, 12 mm (not used)



6 Lock washers, 12 mm (not used)



Bolt, 6 mm (not used)



Nut, 6 mm (not used)



## TOOLS AND SUPPLIES REQUIRED

Phillips screwdriver

Flat-tip screwdriver

10 mm and 17 mm Combination wrenches

14 mm and 17 mm Combination wrenches

10 mm Socket

Ratchet

Drill

6 mm Drill bit

Felt-tip pen

Center punch

Torque wrench

Diagonal cutters

Shop towel

Isopropyl alcohol

Tape measure

13 mm and 24 mm Hole saw

Eye protection (face shield, safety goggles etc.)

Touch-up paint

File

Magnetic pick-up tool

KTC trim tool set: S0JATP2014

## INSTALLATION

**Customer Information:** The information in this installation instruction is intended for use only by skilled technicians who have the proper tools, equipment, and training to correctly and safely add equipment to your vehicle. These procedures should not be attempted by "do-it-yourselfers."

1. Write down the customer's radio station presets; the radio memory will be erased when you disconnect the battery.
2. Disconnect the negative cable from the battery.
3. Open the tailgate.

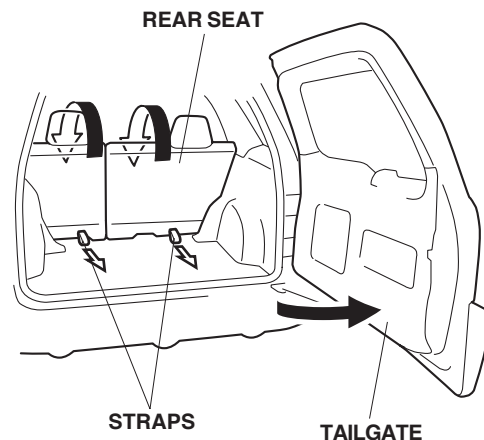

4. Fold down the rear seat.
5. Turn over the cargo area mat, and remove the cargo area floor. Remove the cargo storage bin.

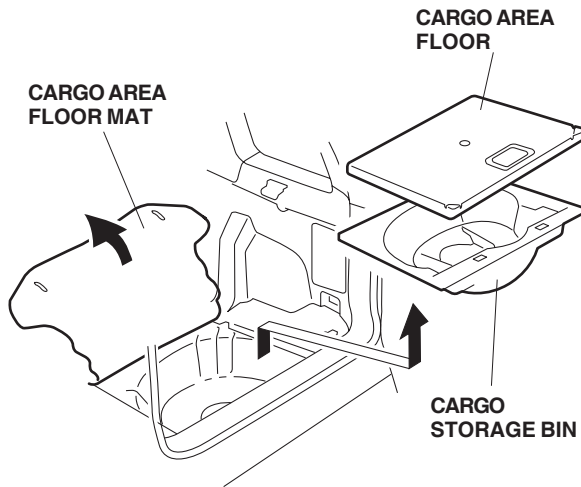

6. Remove the tailgate weatherstrip, and remove the two clips from the rear trim panel. Pry up on the five clips then remove the rear trim panel.

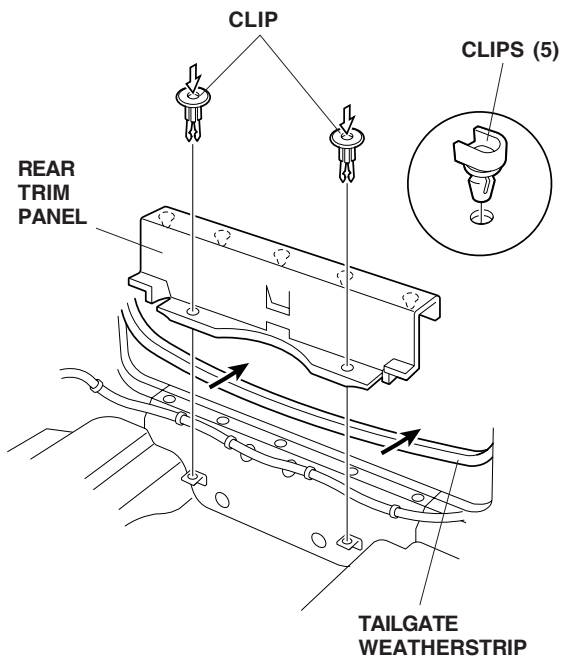

7. Remove the left rear door sill trim (three clips).

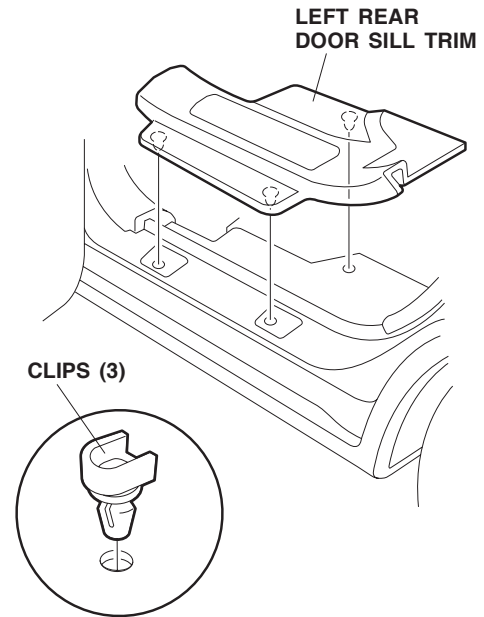

8. Remove the left rear side trim panel:
  - Remove the bolt that secures the tie-down hook to the left rear side trim panel, and remove the tie-down hook.

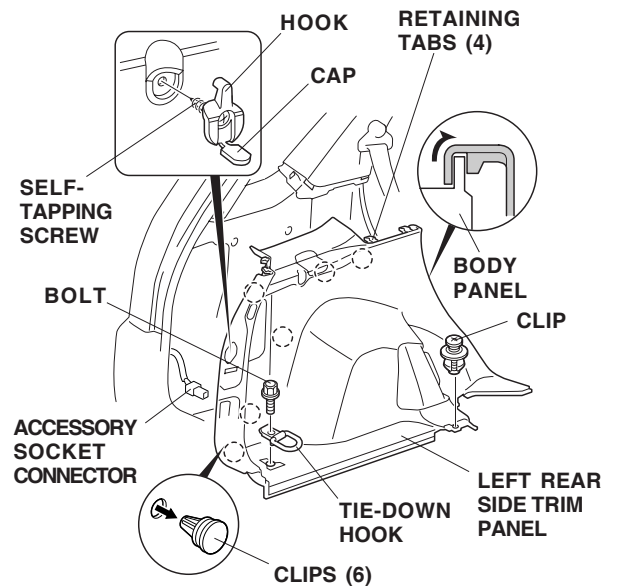

- Open the cap, and remove the self-tapping screw that secures the hook. Remove the hook.
- Remove the clip, and remove the left rear side trim panel from the body panel by starting at the front. Then, release the six clips and four retaining tabs by pulling the left rear side trim panel toward you. Unplug the accessory socket connector, and remove the trim panel.

9. Remove the right side trim panel:
  - Open the jack cover, and remove the jack and the tool kit.

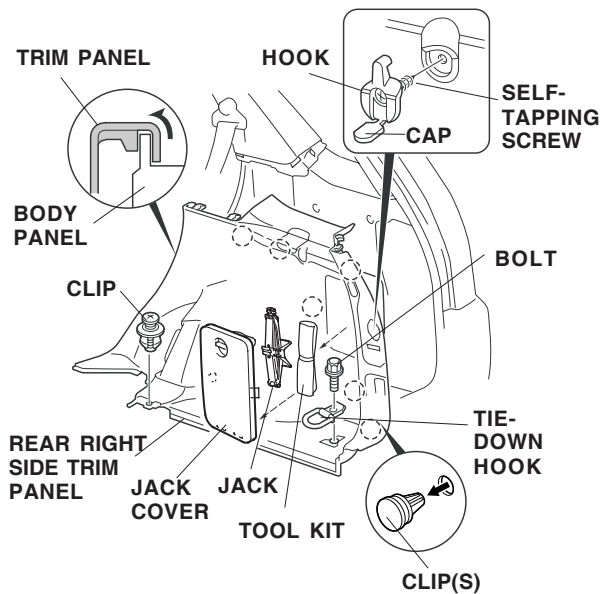

- Open the cap, and remove the self-tapping screw that secures the hook; remove the hook.
  - Remove the clip, and remove the right rear side trim panel. Starting at the front, release the six clips and the four retaining tabs by pulling the rear side trim panel toward you.
10. Remove the two rubber exhaust hangers from the vehicle rods. Remove the left hanger from the rod on the exhaust muffler.

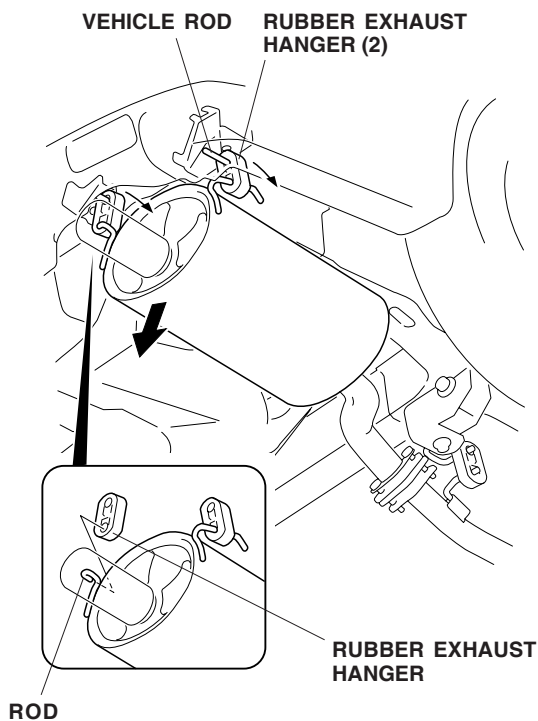

11. Inside the cargo area, locate the two recesses on the floor. While wearing eye protection, drill the trunk floor panel at the rear two recesses. First, drill with a 6 mm bit, and finish with a 24 mm hole saw.

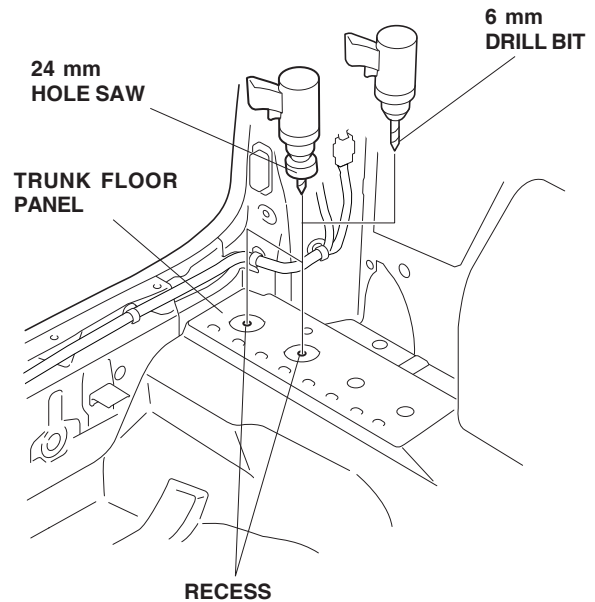

12. If the two recesses are concealed under insulation, measure and mark the insulation using a tape measure and a felt-tip pen. Cut out the insulation at the marked areas, then drill the holes through the two recesses.

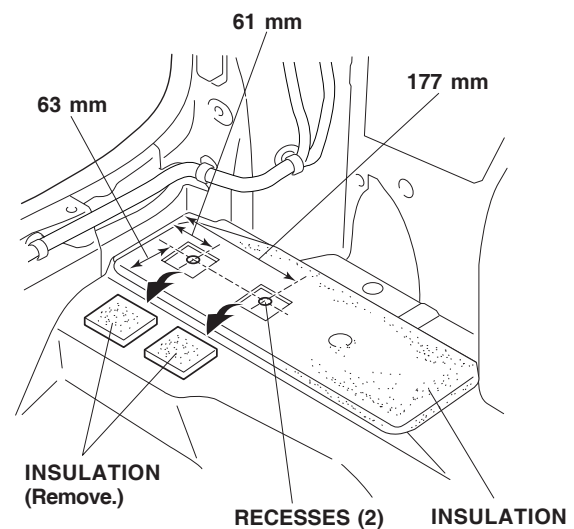

13. While wearing eye protection, drill a 6 mm hole through each of the two recesses located below the 24 mm holes. First, drill with a 6 mm bit, and finish with a 13 mm hole saw.

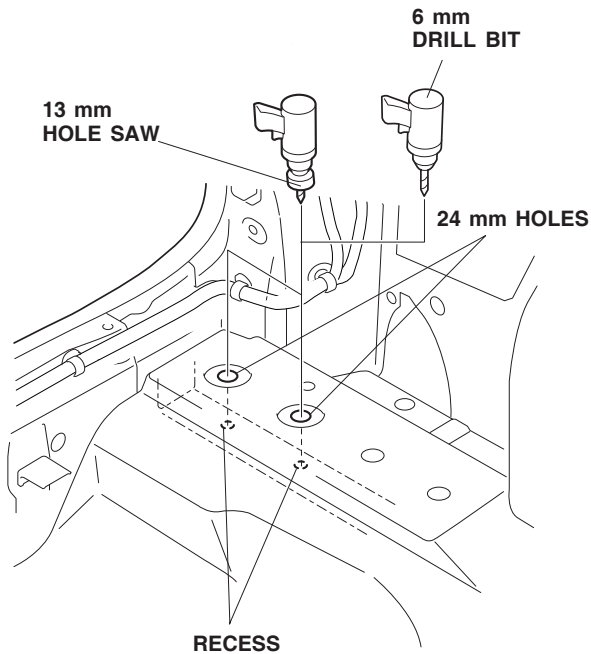

14. Using a magnetic pick-up tool, remove any metal shavings from inside the body panel.
15. Remove any burrs from the edges of all holes, and apply the touch-up paint.

16. Position the left upper plate over the 24 mm holes, and insert a 10 mm bolt into each hole in the left upper plate.

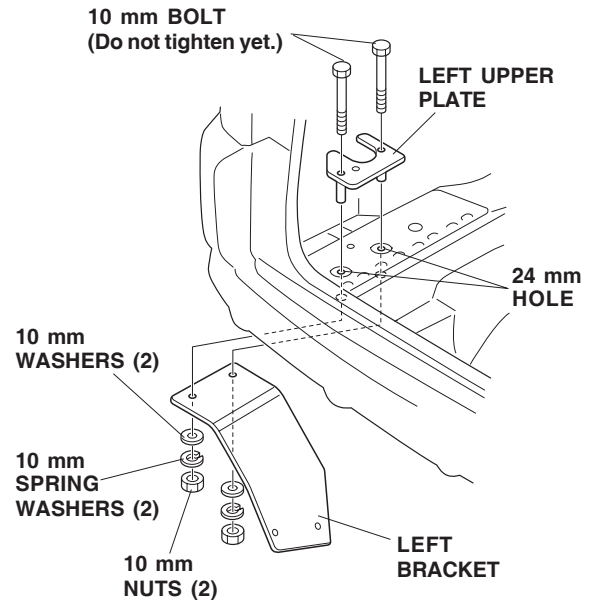

17. Insert the 10 mm bolts into the left bracket, and loosely install the 10 mm washers, 10 mm spring washers and 10 mm nuts on the 10 mm bolts. Do not tighten the 10 mm bolts yet.
18. Repeat steps 11 through 17 to install the right bracket.
19. Get the exhaust rod included in the kit. Slide the rubber exhaust hanger removed in step 10 onto the exhaust rod.

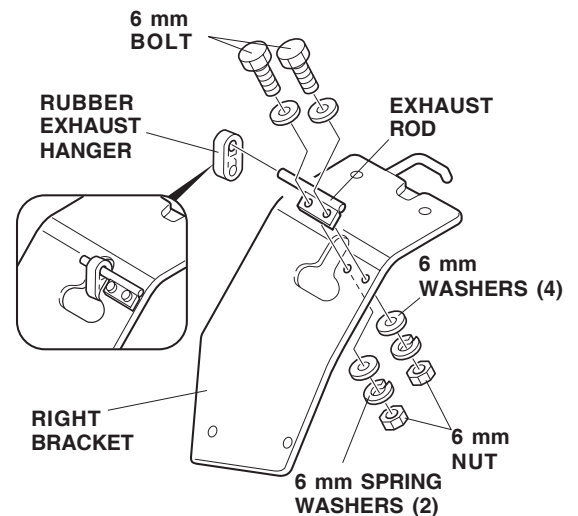

20. Attach the exhaust rod to the right bracket using two 6 x 25 mm bolts, four 6 mm washers, two 6 mm spring washers, and two 6 mm nuts. Torque the exhaust rod bolts to 7.8 N·m (5.8 lb-ft).

- Position the right upper plate over the 24 mm holes, and insert a 10 mm bolt into each hole in the right upper plate.

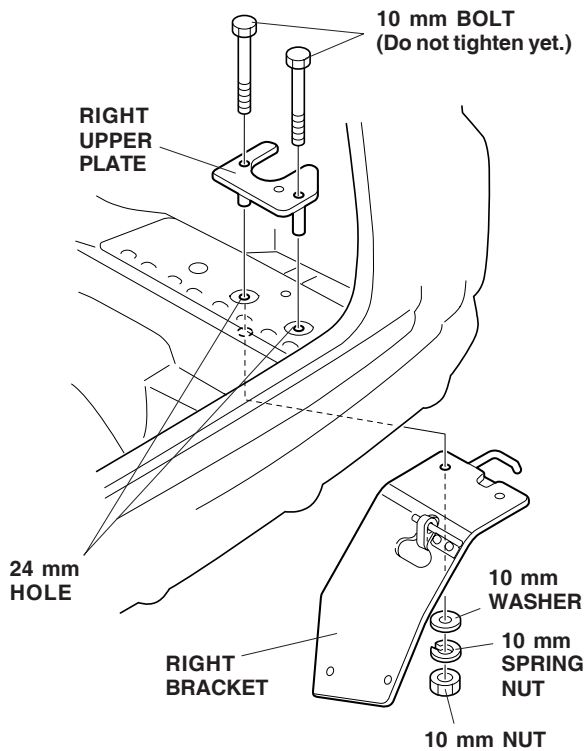

- Insert the 10 mm bolts through the right bracket, and install a 10 mm washer, a 10 mm spring washer, and a 10 mm nut **only** on the front bolt. Do not tighten the 10 mm bolts.

- Attach the inboard rubber exhaust hanger (connected to the right bracket) to the inboard muffler hanger. Take care not to damage the muffler.

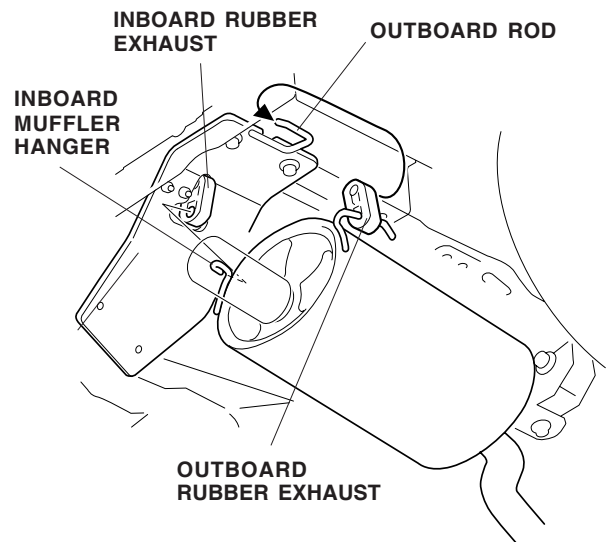

- Attach the outboard rubber exhaust hanger to the outboard rod of the right bracket.
- Position the right bracket over the **rear** 10 mm bolt, and install a 10 mm washer, a 10 mm spring washer, and a 10 mm nut.

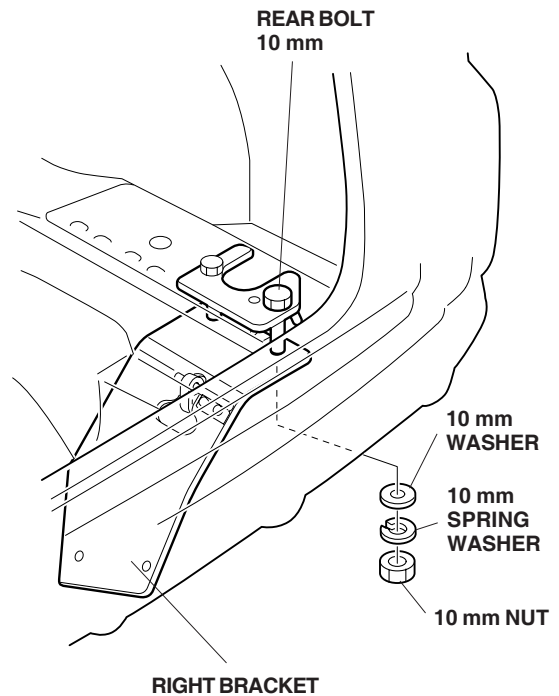

26. Install the trailer hitch on the right and left stays using the two 12 mm bolts, four 12 mm washers, two 12 mm spring washers, and the two 12 mm nuts for each bracket. Do not tighten the 12 mm bolts yet.

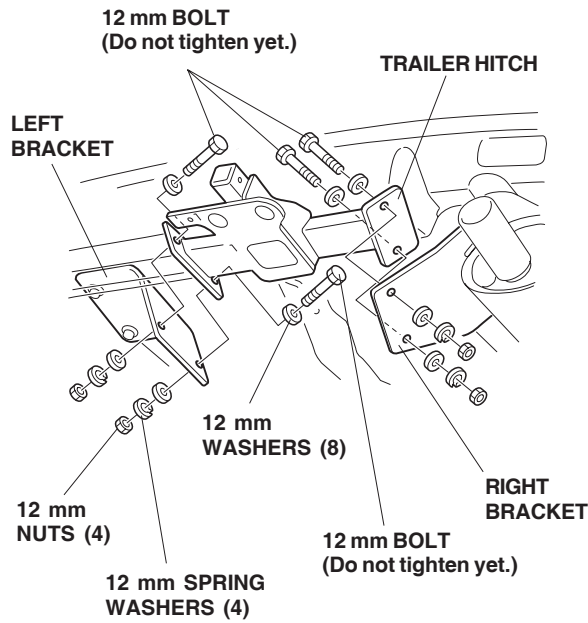

27. Slide the center bracket through the trailer hook.

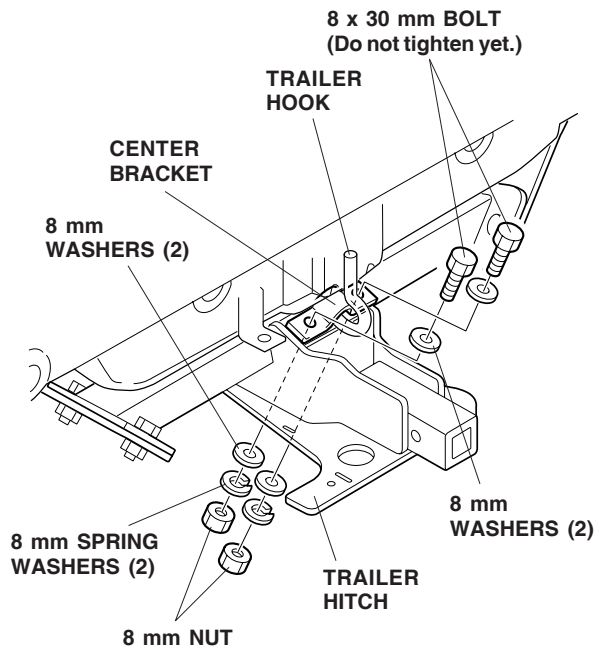

28. Install the center bracket on the trailer hitch using the two 8 x 30 mm bolts, four 8 mm washers, two 8 mm spring washers, and two 8 mm nuts. Do not tighten the 8 mm bolts yet.
29. Tighten all bolts and nuts to the specified torque in the sequence shown (1, 2, and 3).

NOTE: After about 620 miles (1,000 km) of use, the bolts and nuts should be retightened to the specified torque.

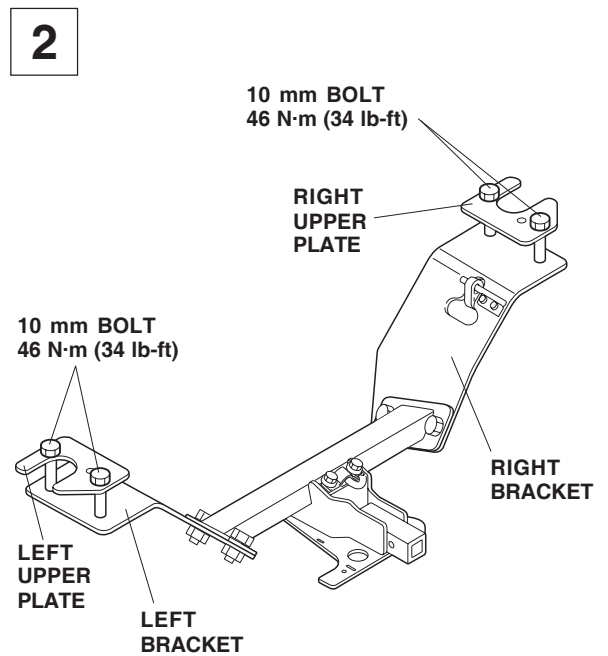
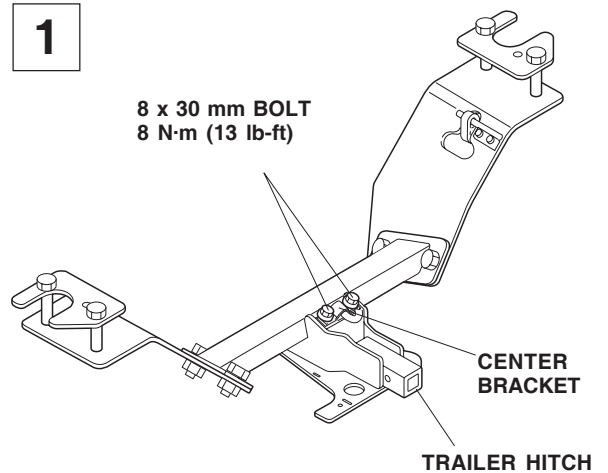

3

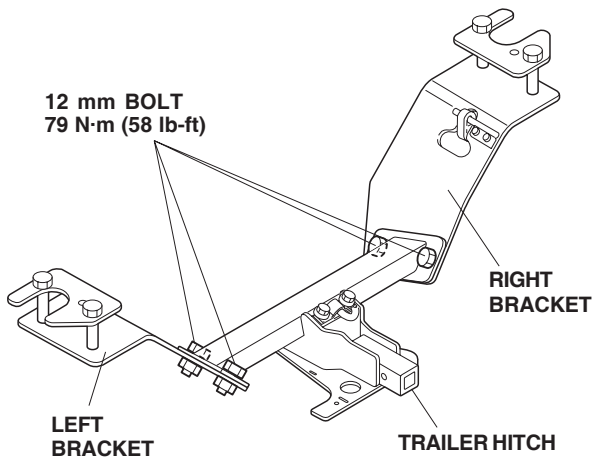

mount, then insert the retaining pin into the holes. Secure the retaining pin with the retaining clip.

### Routing the Trailer Harness

30. Remove and discard the rubber grommet located in the rear panel on the left side.

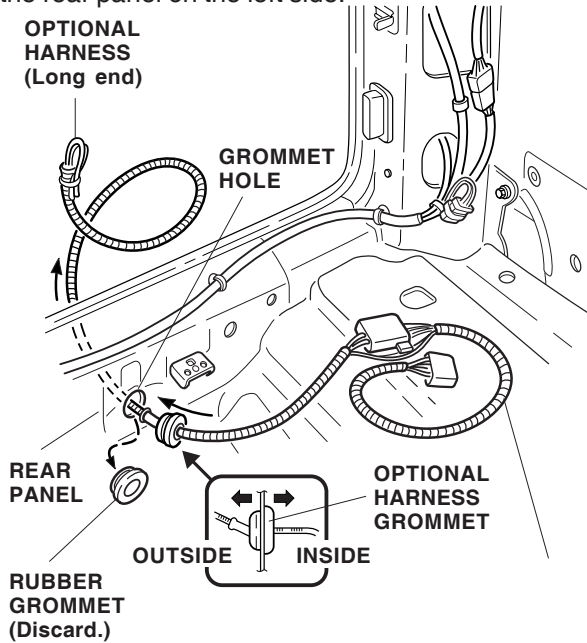

31. Get the optional harness. Route the long end of the optional harness through the grommet hole in the rear panel. Seat the optional harness grommet securely in the grommet hole.

32. At the left rear corner of the cargo area, locate the 6-pin connector blue-taped to the vehicle harness. Remove the blue tape to free the harness.

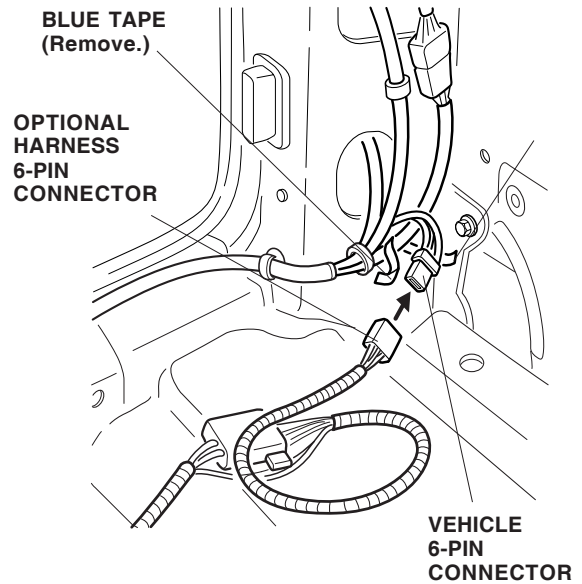

33. Plug the 6-pin connector of the optional harness into the vehicle 6-pin connector.
34. Near the connector, locate and remove the body panel bolt from the lower rear corner.

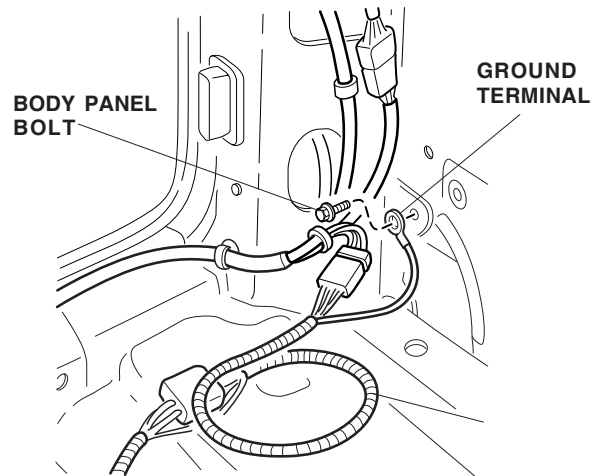



35. Using the body panel bolt, attach the ground terminal from the optional harness to the body. Tighten the bolt securely.
36. Route the optional harness along the vehicle harness and toward the grommet hole.

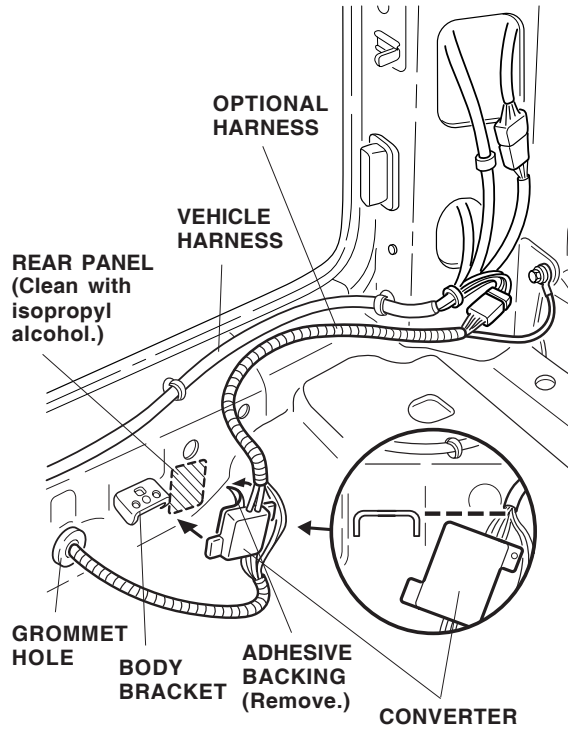

37. Near the body bracket, use isopropyl alcohol on a shop towel to clean the area where the converter will attach.

38. Remove the adhesive backing and attach the converter to the body, next to the body bracket. Make sure the top of the converter is below the bracket.
39. Secure the optional harness to the vehicle harness with two wire ties in the area shown. Wrap one cushion tape around the 6-pin connector.

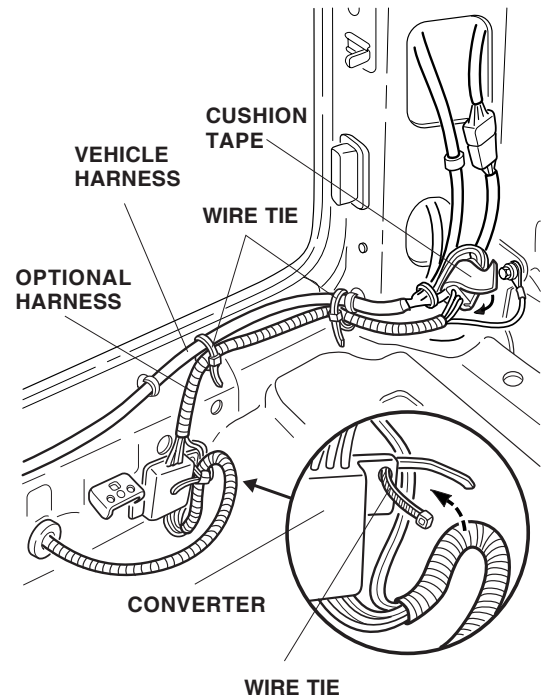

40. At the converter, secure the excess harness to the converter with one wire tie. Cut the excess length off of the wire ties.
41. Reinstall all of the interior trim pieces.

41. On the outside of the vehicle, pull the excess harness from under the bumper area. Bundle up the excess harness, and wire tie the excess harness under the vehicle. You can also cut the harness to the proper length, and then wire tie the excess harness under the vehicle.

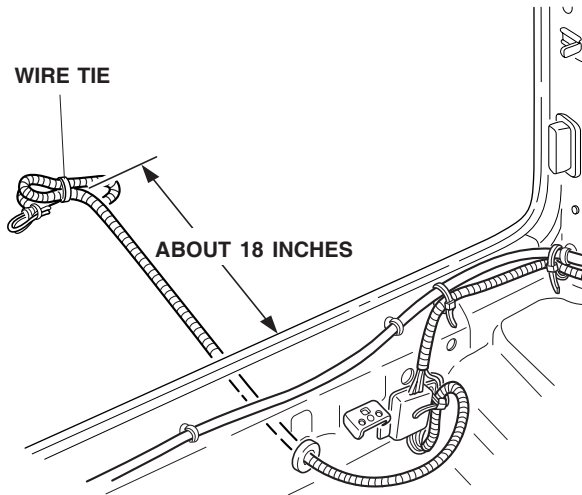

42. Slide the ball mount into the trailer hitch. Align the holes in the trailer hitch with the holes in the ball

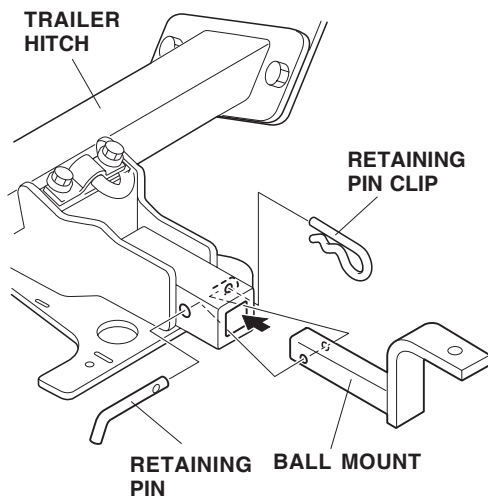

43. Install the receiver cover on the trailer hitch when the ball mount is removed.

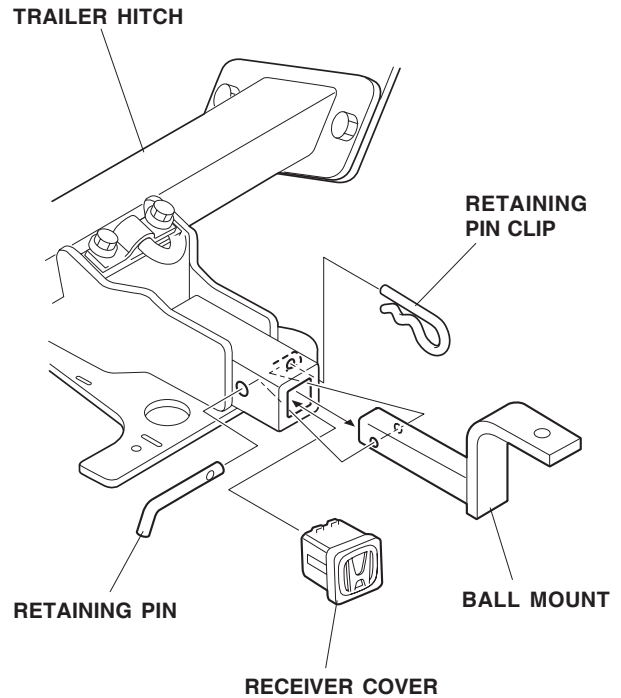

44. Reinstall all of the interior trim pieces.  
 45. Reconnect the negative battery cable.  
 46. Reset the clock and the radio station presets.

**NOTE:** Whenever the battery is disconnected, the driver's AUTO function is disabled.

47. Start the engine. Push down on the driver's window switch until the window is fully open.  
 48. Pull up on the driver's window switch to close the window completely, then hold the switch for 2 seconds or more.  
 49. Use the window switch to check the AUTO window function.  
 50. Do the idle learn procedure.
- Make sure all electrical items (A/C, audio unit, defogger, lights, etc.) are turned off.
  - Start the engine, and let it warm up to its normal operating temperature (the cooling fans cycle twice).
  - Let the engine idle (throttle fully closed and all electrical items off) for 10 minutes.