



INSTALLATION INSTRUCTIONS

Accessory

FRONT GRILLE TRIM
P/N 08P01-S9A-100A

Application

2006 CR-V

Publications No.

All 30562

Issue Date

SEP 2005

PARTS LIST

Front grille trim

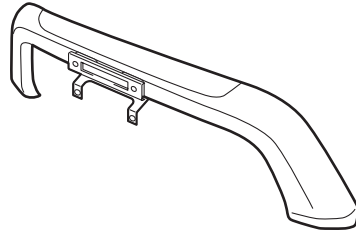

6 Screws



6 Washers



Washer-nut



4 Washer-bolts



TOOLS AND SUPPLIES REQUIRED

Phillips screwdriver

Flat-tip screwdriver

Ratchet

10 mm Socket

Drill

3 mm, 6.5 mm and 10 mm Drill bits

Blanket

Eye protection (face shield, safety goggles, etc.)

File

Center punch

INSTALLATION

Customer Information: The information in this installation instruction is intended for use only by skilled technicians who have the proper tools, equipment, and training to correctly and safely add equipment to your vehicle. These procedures should not be attempted by "do-it-yourselfers."

NOTE: Be careful not to damage the body paint finish.

1. Remove the front license plate (four self-tapping screws).

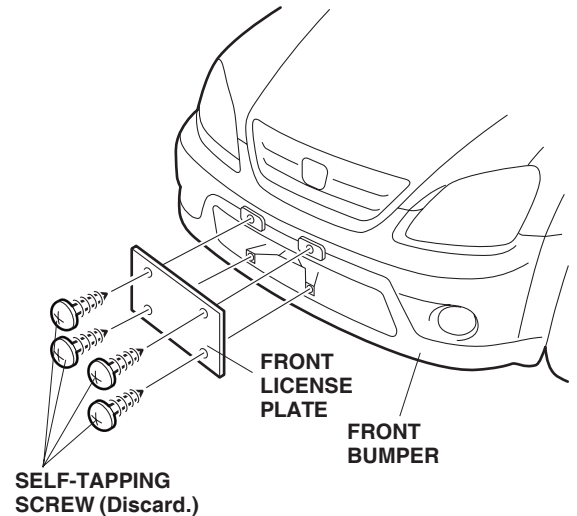

2. Remove the brackets from the front bumper (one bolt). Set the bolt and the brackets aside; they will not be reused.

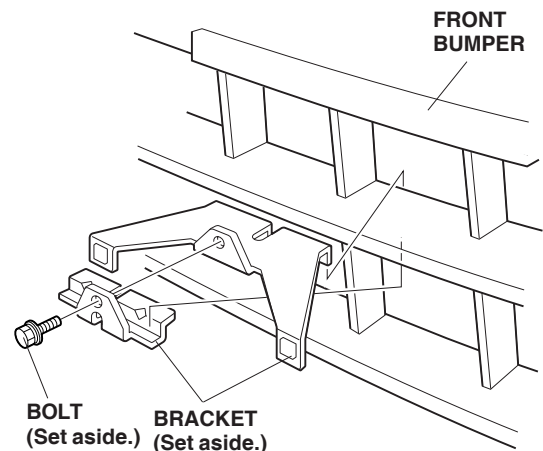

- Open the hood. Remove the radiator cover (seven clips and one bolt).

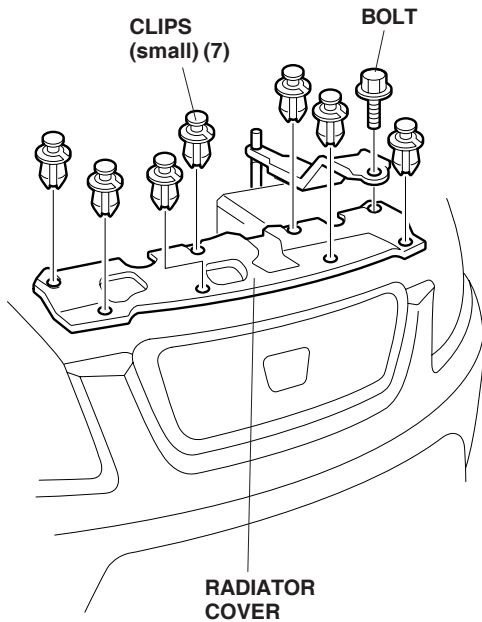

- Remove the eight clips and four self-tapping screws that fasten the front bumper. If equipped, unplug the fog light connectors, remove the front bumper, and set it on a blanket to install the front grille trim.

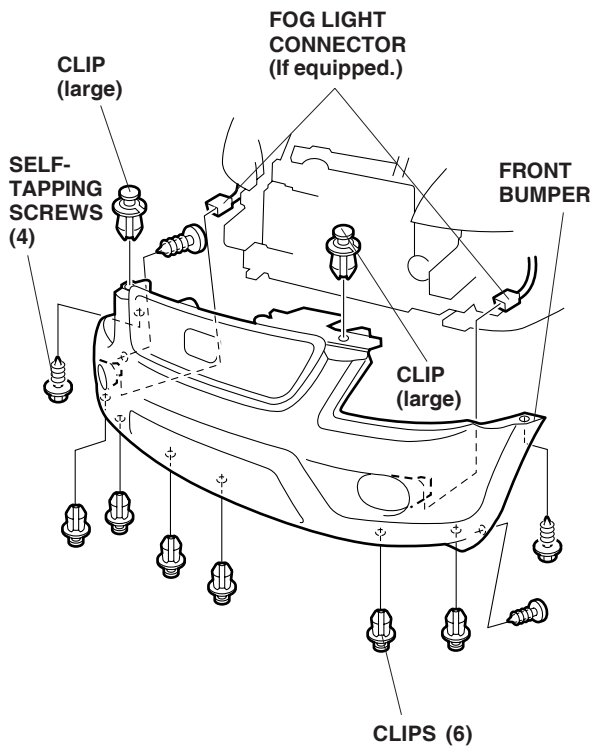

- Remove and discard the license plate screw holders (two screws for each holder).

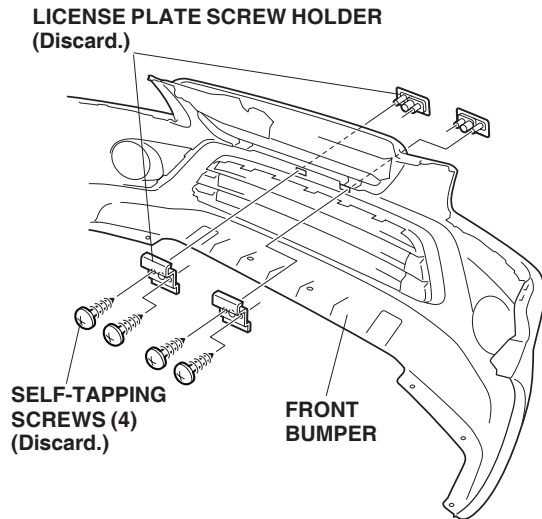

- On the inside of the front bumper, locate the seven marks. Center-punch each mark.

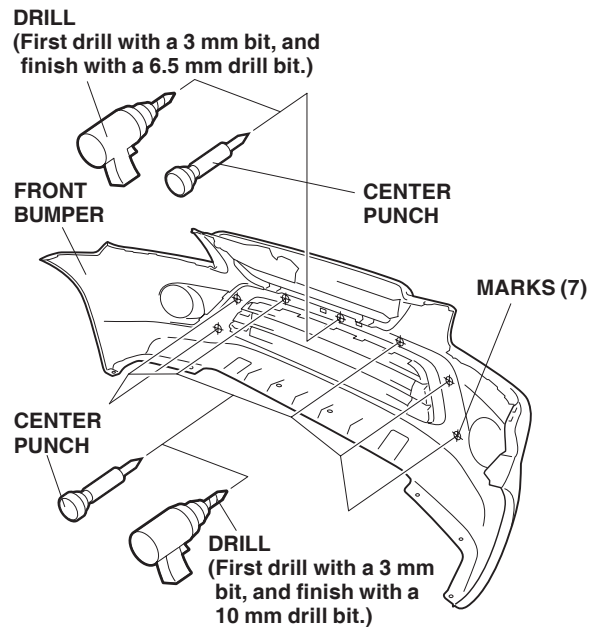

- While wearing eye protection, drill the center mark to 6.5 mm and drill the remaining six marks to 10 mm:
 - First drill all of the marks with a 3 mm drill bit.
 - Drill the center hole with a 6.5 mm drill bit.
 - Drill the remaining outboard holes with a 10 mm drill bit.
 - Using a file, remove any burrs from the holes.

8. Position the front grille trim on the bumper, and insert the stud from the grille trim into the center hole in the front bumper.

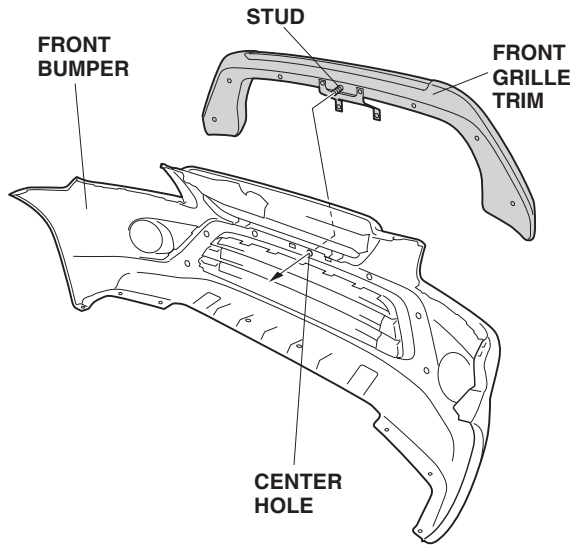

9. Install the washer-nut on the end of the stud, then install one screw with washer through the remaining six holes and into the front grille trim. Torque the washer-nut to 9 N·m (7 lbf-ft).

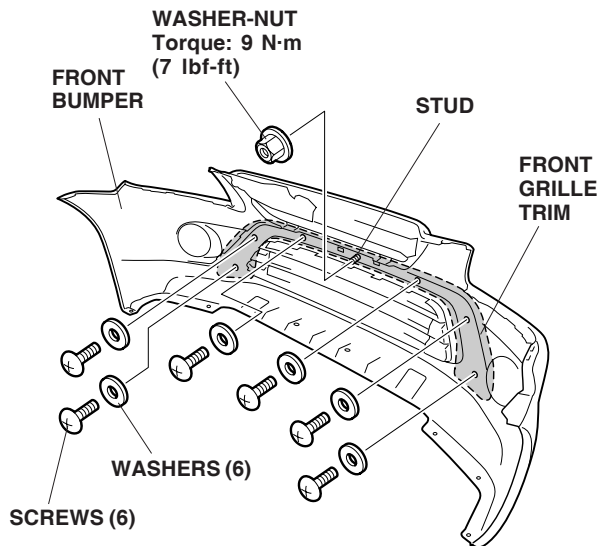

10. Reinstall the front bumper and radiator cover. If equipped, plug in the fog light connectors.

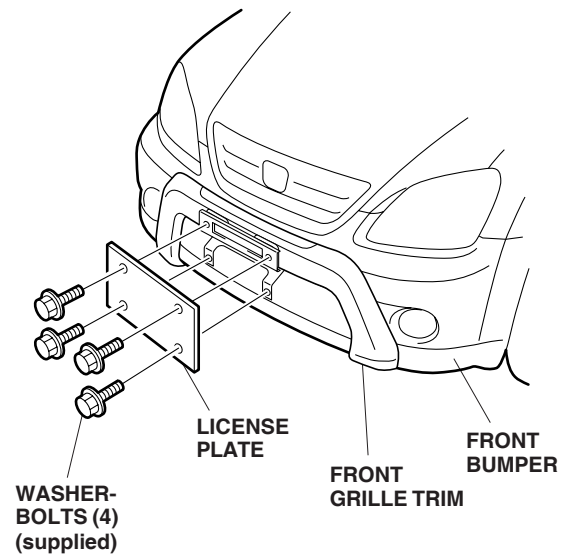

11. Install the license plate on the front grille trim with the four washer-bolts supplied.