



INSTALLATION INSTRUCTIONS

Accessory

**BACKUP SENSOR
P/N 08V67-S9A-100**

Application

2006 CR-V

Publications No.

All 30576

Issue Date

SEP 2005

PARTS LIST

Control unit

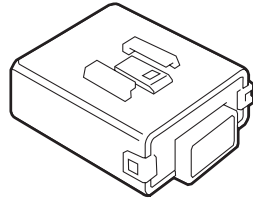

2 Center sensors

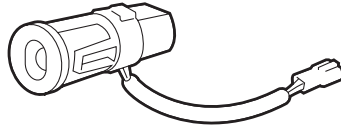

2 Corner sensors

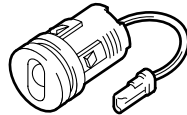

Beeper

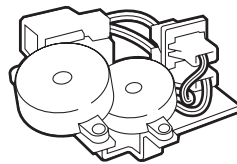

2 Retainer clips



Backup sensor harness

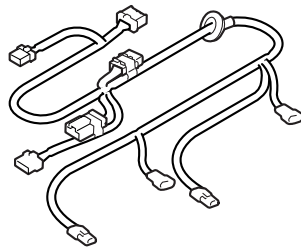

Control unit bracket

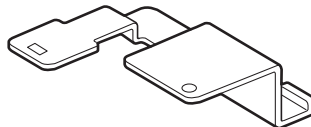

Flange bolt

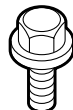

Fuse label

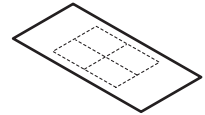

Panel seal

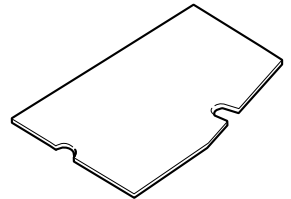

Screw



2 Nuts



3 Wire ties with clip "A"

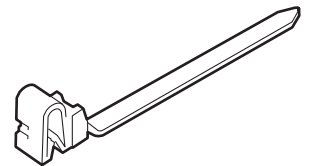

2 Self-tapping screws



2 Clips



4 Wire ties

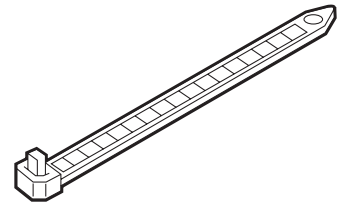

2 Wire ties with clip "B"

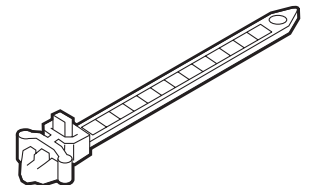

Owner's Manual

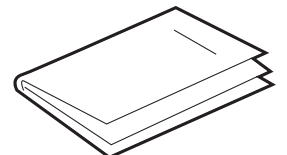

TOOLS AND SUPPLIES REQUIRED

Phillips screwdriver
Stubby Phillips screwdriver
Flat-tip screwdriver
Ratchet
10 mm and 12 mm sockets
Tape measure
10 mm wrench
20 mm and 26 mm hole saws
File
Pushpin
Felt-tip pen
Clip remover
Scissors
Utility knife
Eye protection (safety goggles, face shield, etc.)
Blanket

Illustration of the Backup Sensor Installed on the Vehicle:

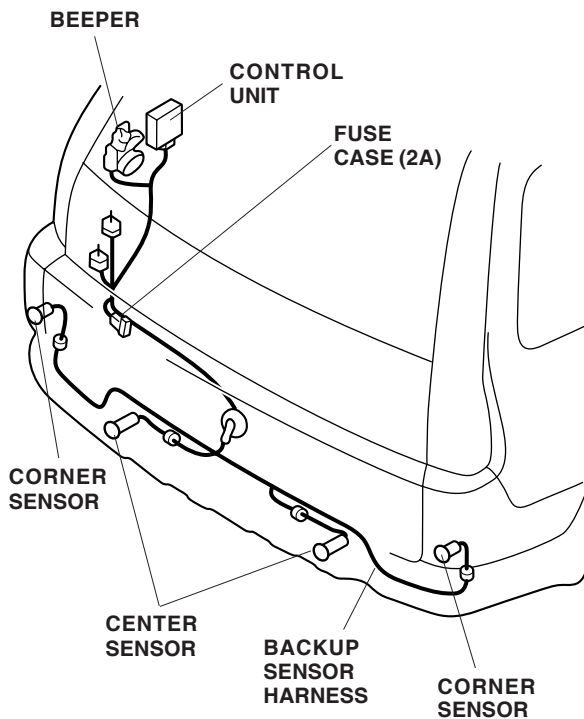

INSTALLATION

Customer Information: The information in this installation instruction is intended for use only by skilled technicians who have the proper tools, equipment, and training to correctly and safely add equipment to your vehicle. These procedures should not be attempted by “do-it-yourselfers.”

1. Make sure you have the anti-theft code for the radio, then write down the radio station presets.
2. Disconnect the negative cable from the battery.
3. Remove the left rear splash guard (three self-tapping screws).

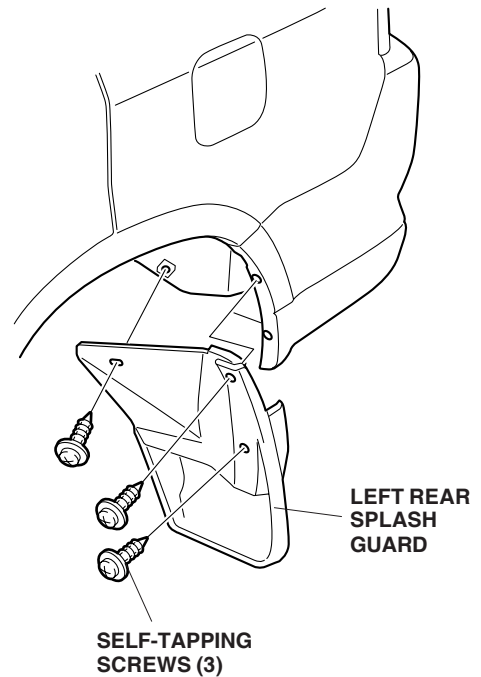

4. Repeat on the right rear splash guard (three self-tapping screws).

5. Open the tailgate, and attach a piece of duct tape to the tailgate trim on the right side of the tailgate.
6. Remove the two bolt covers from the left side of the rear bumper. Remove the two washer-bolts from each side of the rear bumper.

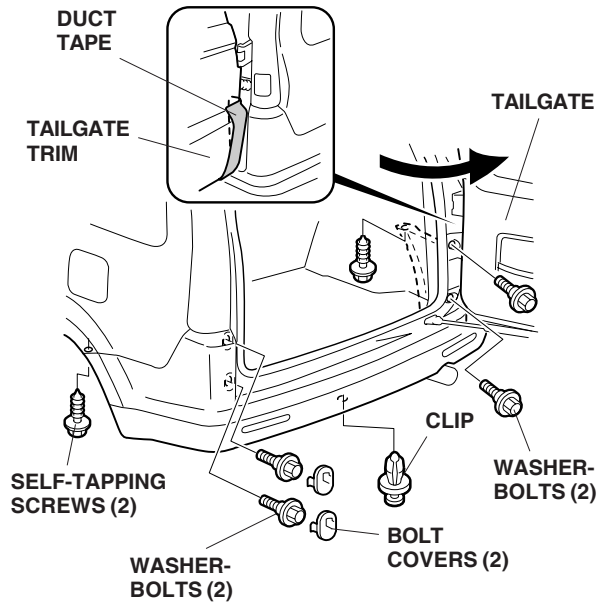

7. Remove the center clip, and remove the self-tapping screw from each side of the rear bumper.

8. With an assistant holding the tailgate, remove the screw that secures the tailgate open stay.

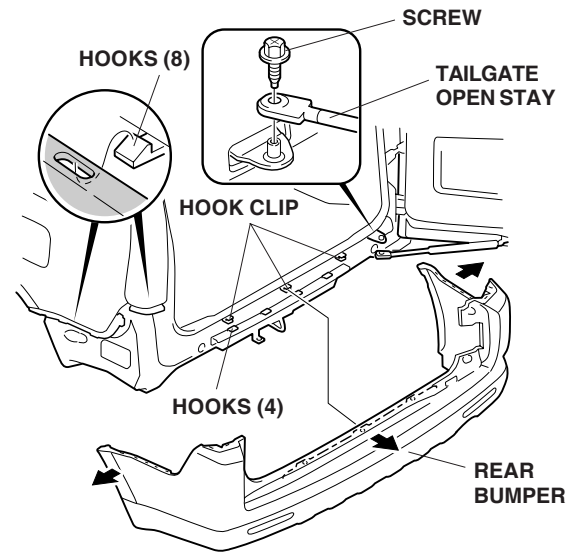

9. Open both sides of the rear bumper, disengage the hooks and remove the rear bumper by pulling it outward. Be careful not to hit the bumper against the tailgate. Set the rear bumper on a blanket.

NOTE: Hold the tailgate at an angle until the gap between the bumper and tailgate is the widest, then remove the bumper with care.

10. Fold down the rear seatbacks, then fold down the rear seat cushions assembly forward.

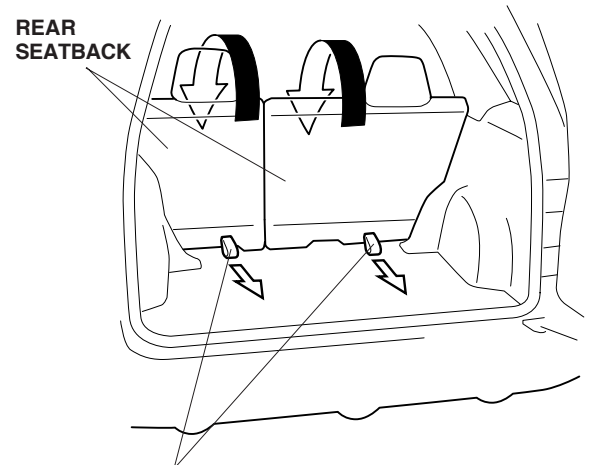

Pull the straps to fold down the rear seat cushions.

11. Fold the trunk floor mat forward, and remove the cargo floor lid and rear floor bucket.

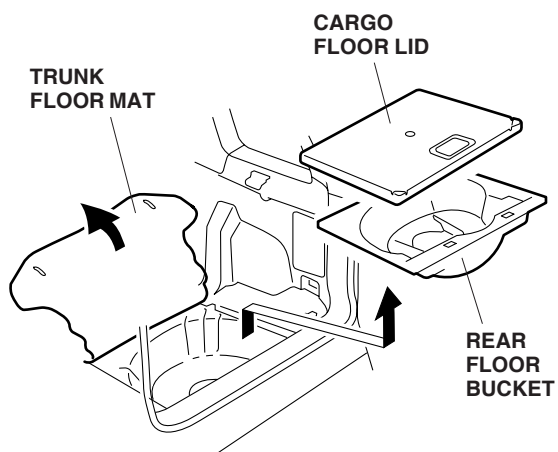

12. Remove the weatherstrip from around the rear panel liner. Remove the two clips from the rear panel liner.

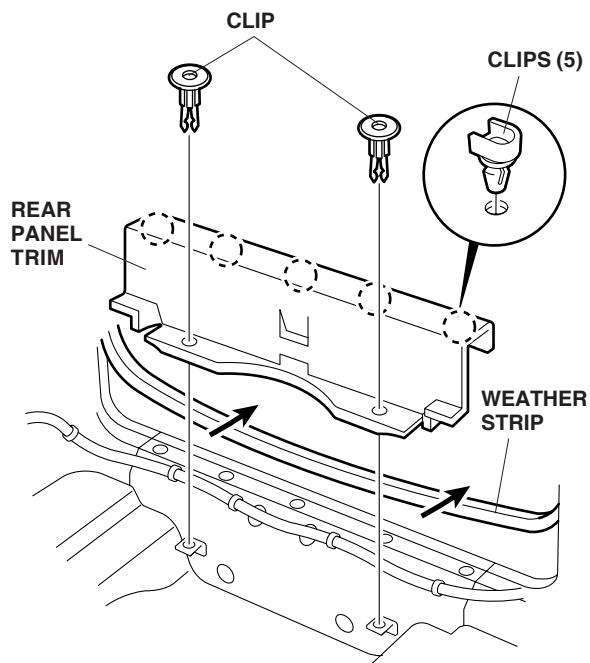

13. Remove the rear trim panel (five clips).

14. Remove the left rear door side sill trim (three clips).

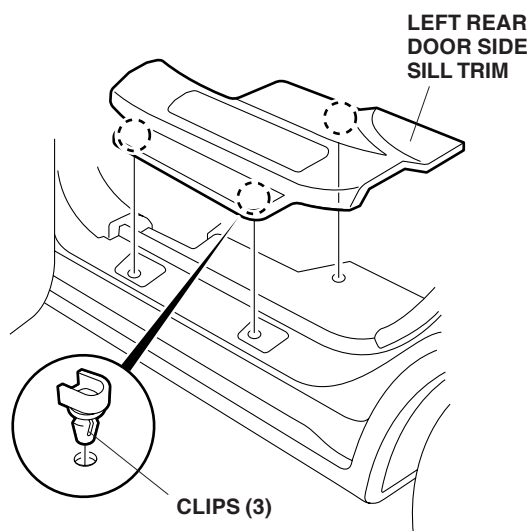

15. Inside the cargo area, remove the rear tie-down hook on the left side (one bolt).

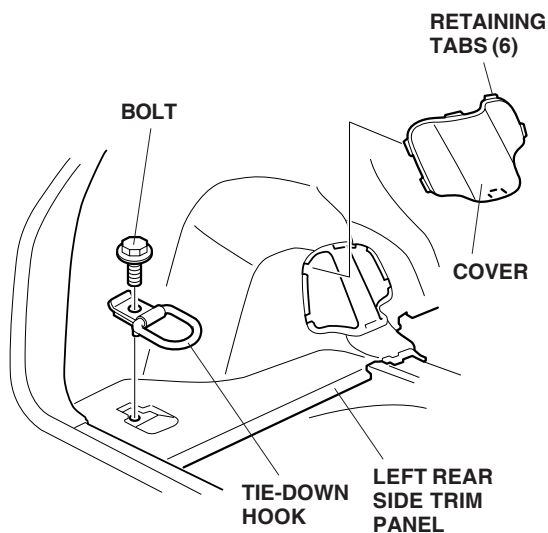

16. Remove the cover from the left rear side trim panel (six retaining tabs).

- Remove the screw cover from the hook, and remove the hook (one self-tapping screw).

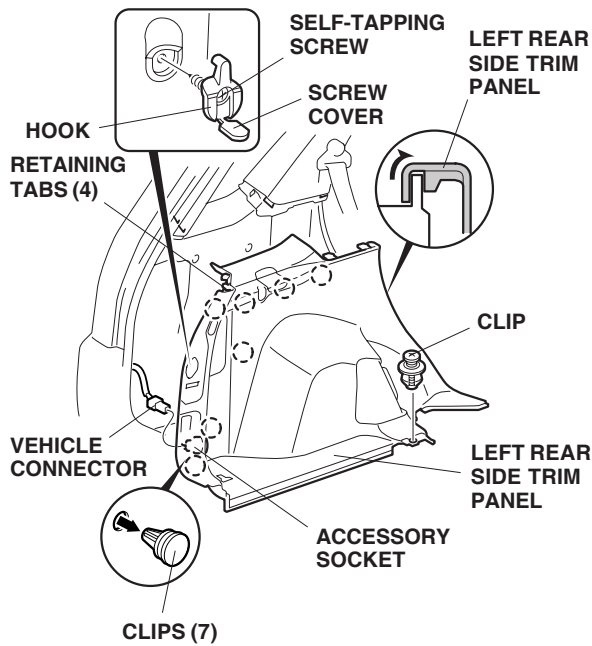

- Remove left rear side trim panel (one clip, four retaining tabs, seven clips then pull the liner out toward you, and unplug the accessory socket).

Installing the Sensor

- On the inside of the rear bumper, locate the four preset marks. Using a pushpin, pierce a hole through each of the four marks.

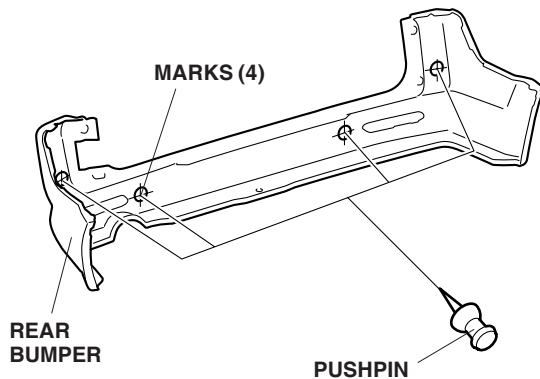

- While wearing eye protection, drill a 20 mm hole through each of the two outer marks, and a 26 mm hole through each of the inner marks. Remove any burrs from the edges of the holes.

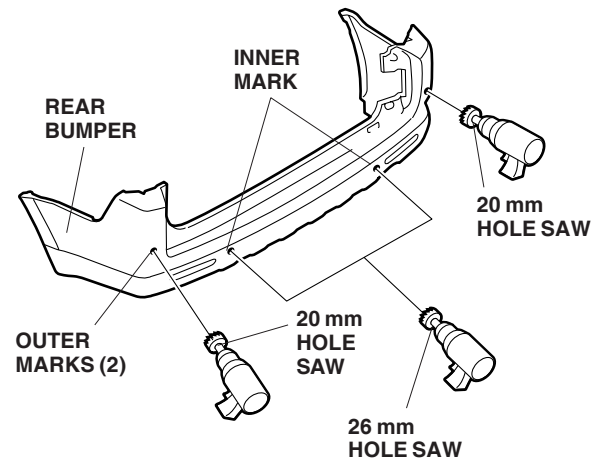

- Separate the corner sensors from the corner sensor trims. Install the corner sensor trims first, then install the corner sensors through the 20 mm holes you just made, with the "UP" mark facing up.

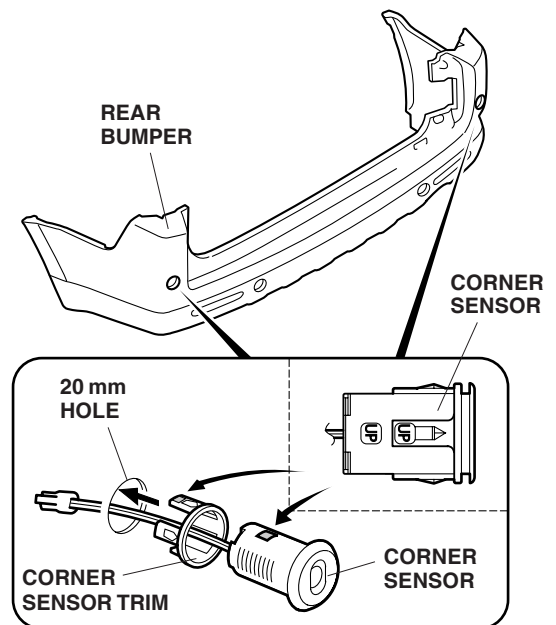

22. Install the two center sensors into the 26 mm holes. Secure the center sensors using one retainer clip for each sensor.

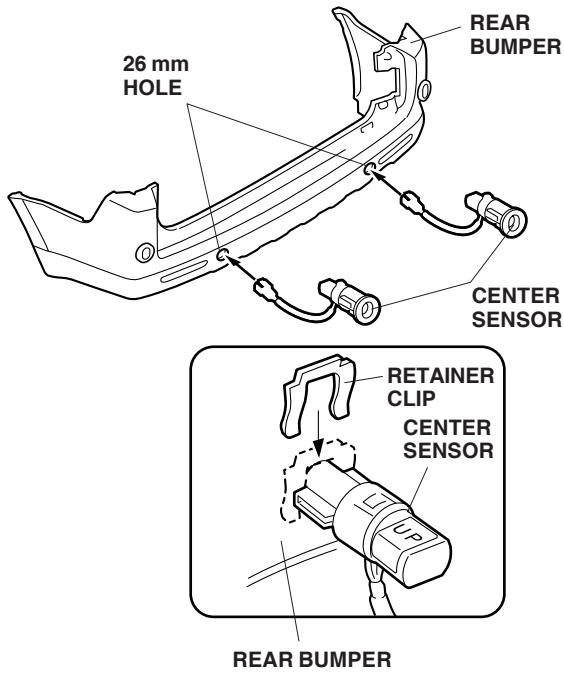

Routing the Backup Sensor Harness

23. Get the beeper, the control unit bracket, and the backup sensor harness. Position the beeper on the control unit bracket, then install the flange bolt and nut.

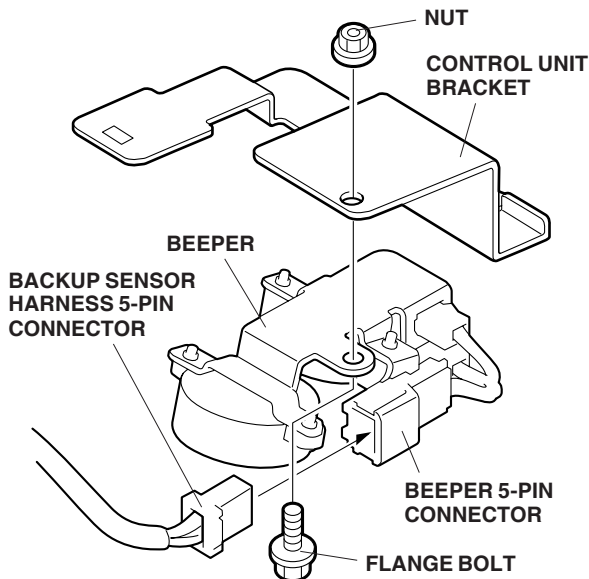

24. Plug the backup sensor harness 5-pin connector into the beeper 5-pin connector.

25. Slide the control unit onto the control unit bracket, and plug the backup sensor harness 22-pin connector into the control unit.

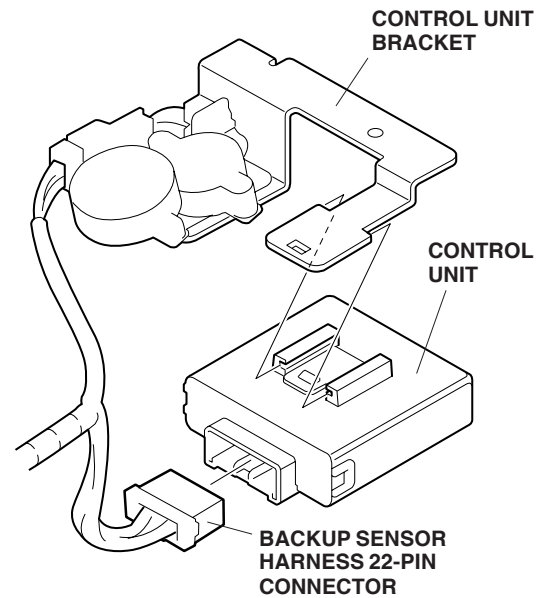

26. Inside the cargo area, remove and discard the vehicle hole seal.

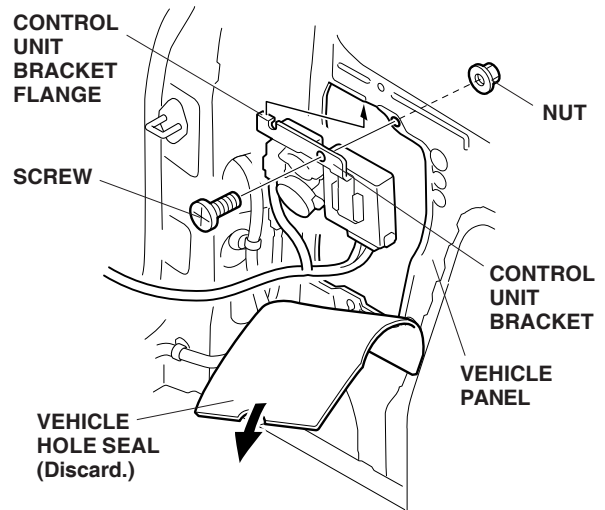

27. Position the control unit bracket on the vehicle panel, and install the screw and nut while pushing the control unit bracket flange against the vehicle panel. Tighten the screw and nut securely.

- Route the backup sensor harness 6-pin connector and grommet through the hole in the vehicle panel.

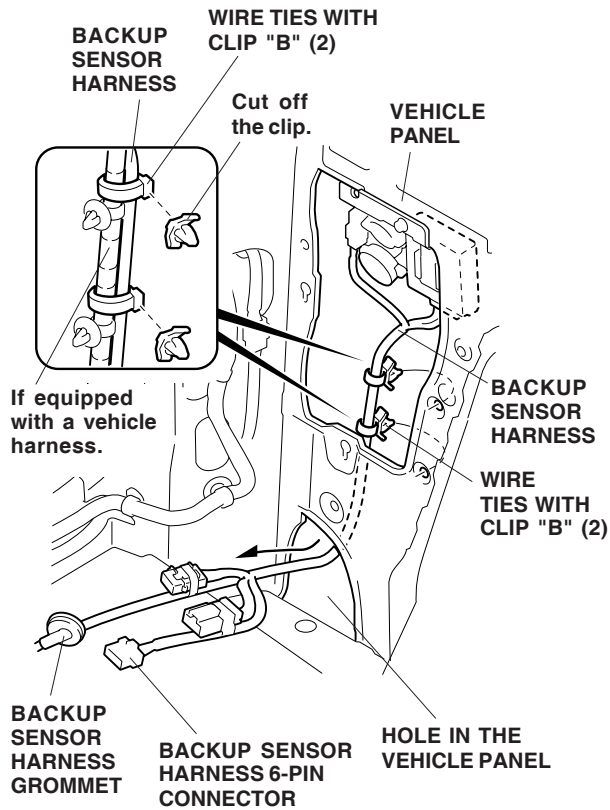

- Using two wire ties with clip "B", secure the backup sensor harness to the vehicle panel. If there is already a vehicle harness using the two vehicle panel holes, cut off the clips from the two wire ties, and secure the backup sensor harness to the existing vehicle harness.

- Attach the 2A fuse label to the backup sensor harness fuse case.

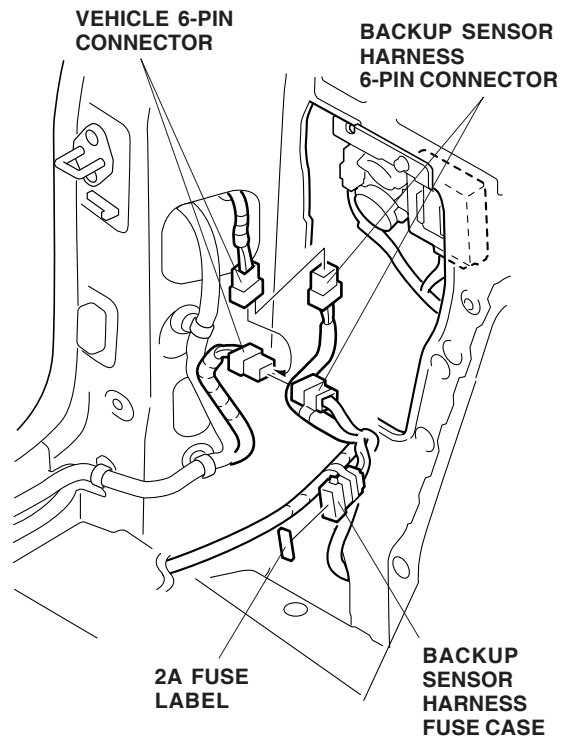

- Unplug the taillight 6-pin connectors, and plug the backup sensor harness 6-pin connectors in between the vehicle 6-pin connectors you just unplugged.
- Remove and discard the grommet from the vehicle panel.

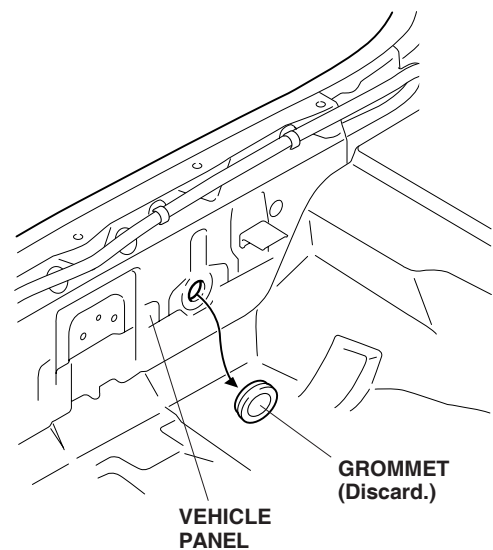

33. Route the four backup sensor harness 2-pin connectors through the vehicle grommet hole from the inside to the outside of the vehicle. Install the backup sensor harness grommet in the vehicle panel securely.

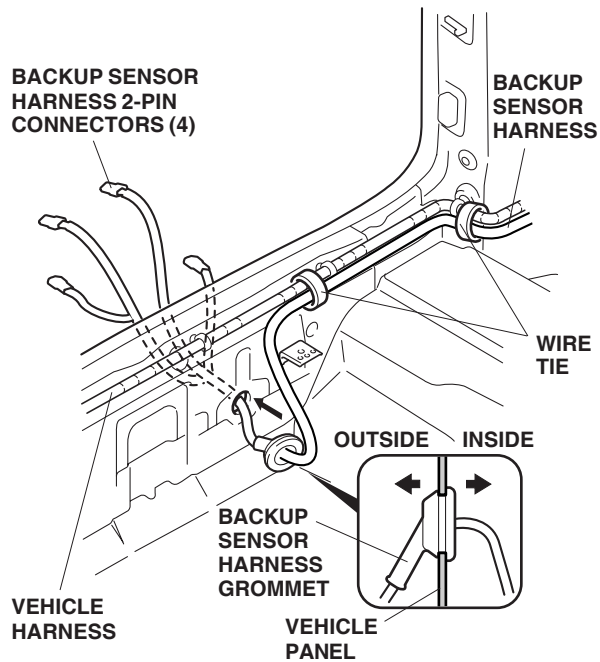

34. Using two wire ties, secure the backup sensor harness to the vehicle harness.

35. With the help of an assistant, plug the four backup sensor harness 2-pin connectors into the two center sensor connectors and two corner sensor connectors located on the rear bumper. Reinstall the rear bumper.

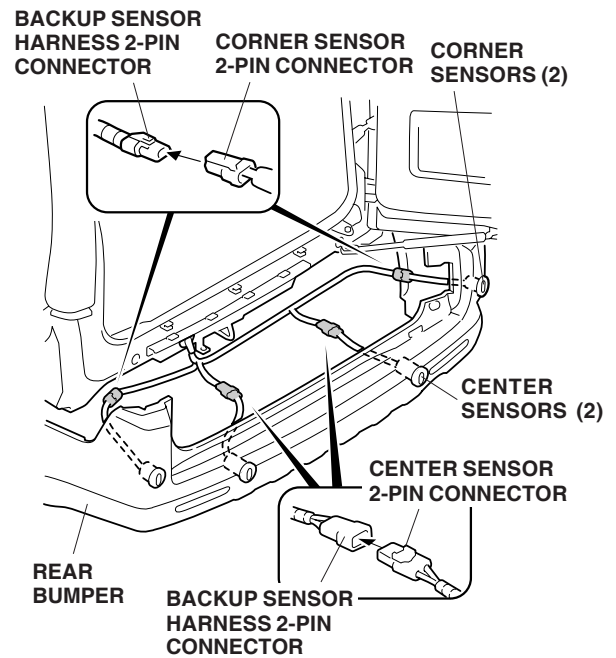

36. Get three wire ties with clip "A." Attach one wire tie with clip "A" at each of the green-taped areas on the backup sensor harness. Slide each of the wire ties with clip "A" onto the ribs of the rear bumper.

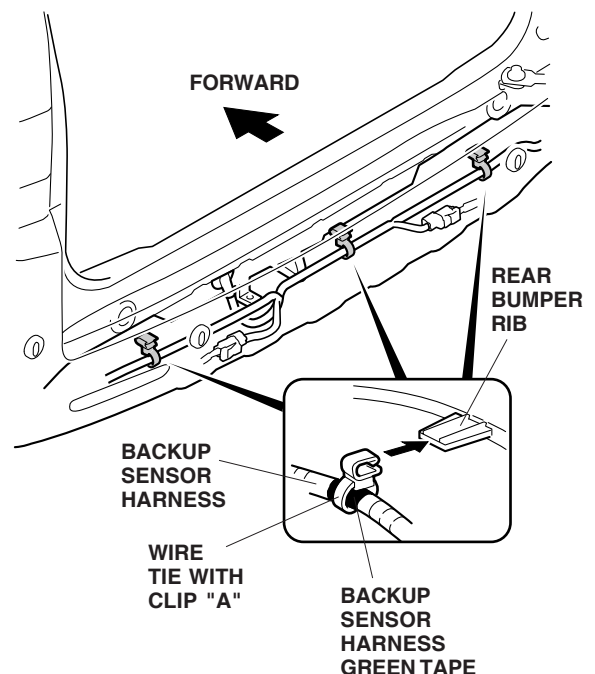

37. Using one wire tie, secure each center sensor 2-pin connector to the backup sensor harness.

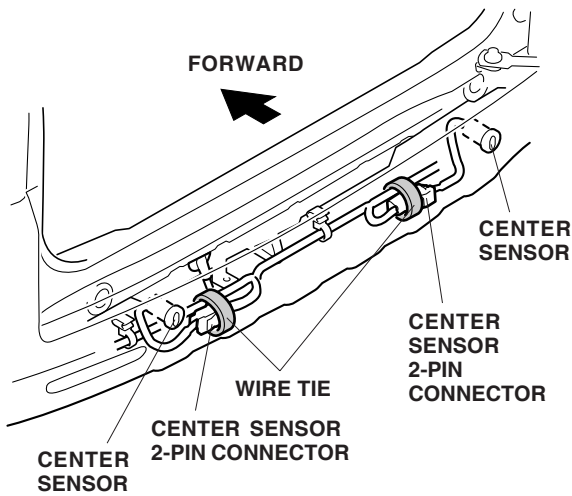

38. Attach the clip to the backup sensor harness at the location, then secure the harness to the boss on the rear bumper using the self-tapping screw.

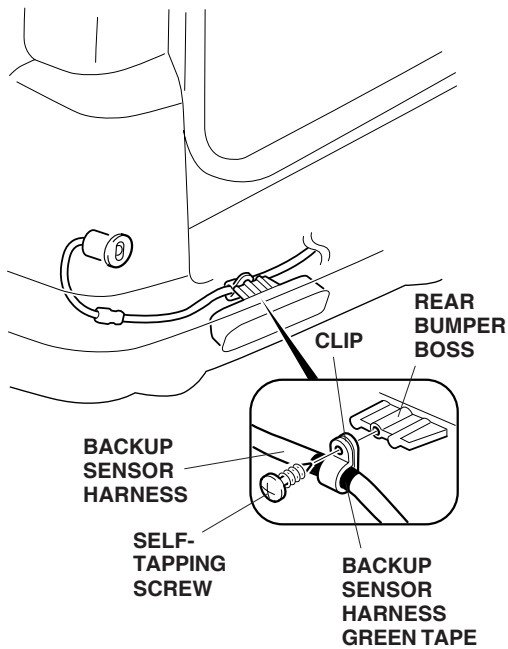

39. Attach a clip to the harness on the right side the same way.

Installing the Panel Seal

40. Using a utility knife, cut out the panel seal using the measurements shown.

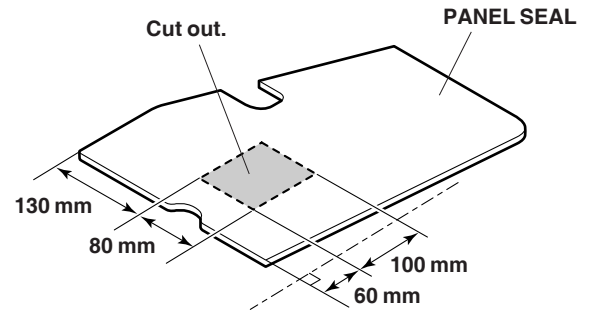

41. Align the panel seal over the beeper on the vehicle panel, and attach the panel seal by removing the adhesive backing.

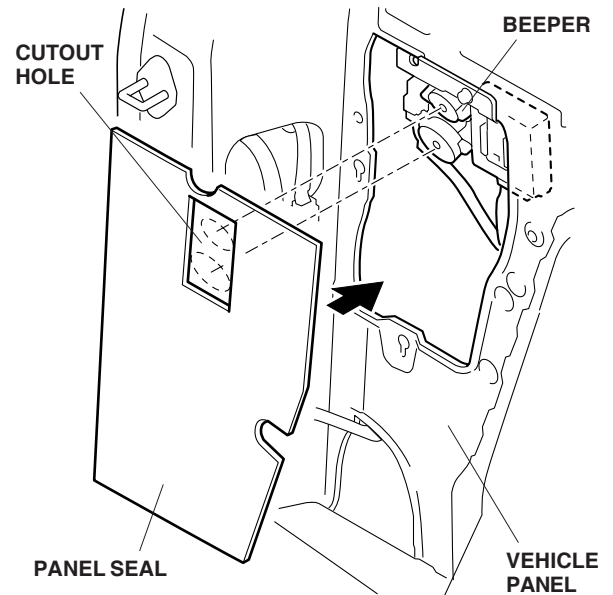

42. Check that all wire harnesses and cables are routed properly, and that all connectors are plugged in.
43. Reinstall all removed parts.
44. Reconnect the negative cable to the battery.
45. Enter the customer's radio anti-theft code, and reset the radio station presets.
46. Reset the clock.
47. Check that the backup sensors work properly as described in the Owner's Manual supplied with the backup sensor kit.

NOTE: Whenever the battery is disconnected, the driver's window AUTO function is disabled.

48. Start the engine. Push down on the driver's window switch until the window is fully open.
49. Pull up on the driver's window switch to close the window completely, then hold the switch for 2 seconds or more.
50. Lower and raise the window to check operation of the driver's window AUTO function.