



INSTALLATION INSTRUCTIONS

Accessory
ARMREST WITH STORAGE COMPARTMENT
P/N 08U89-S9A-110 (BLACK)
P/N 08U89-S9A-120 (SADDLE)

Application
**2006 CR-V
(WITH A/T ONLY)**

Publications No.
All 30570
Issue Date
SEP 2005

PARTS LIST

Armrest box

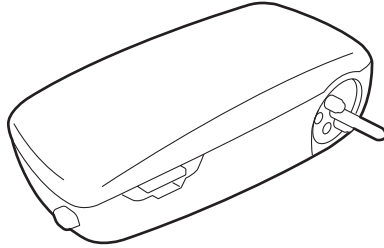

Base



2 Socket bolts



Owner's Manual

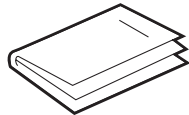

TOOLS REQUIRED

- Ratchet
- 10 mm and 17 mm Sockets
- 5 mm Hex wrench
- Torque wrench

INSTALLATION

NOTE: Take care not to tear the seams or damage the seat covers.

1. Remove the cap.

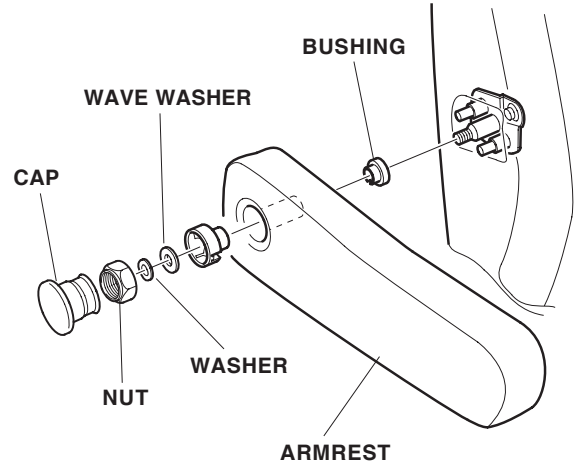

2. Remove the nut, the washer, and the wave washer, then remove the armrest. If necessary, remove the bushings from the armrest.
3. Remove the bolts, then remove the armrest bracket.

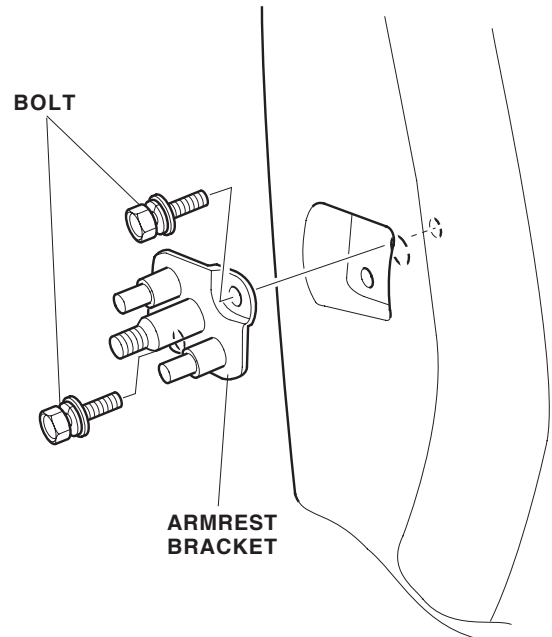

7. Get the new base from the kit, and position it on the pin base of the seat. Install the two socket bolts, Torque the socket bolts to 10-12 N·m (7-9 lbf-ft).

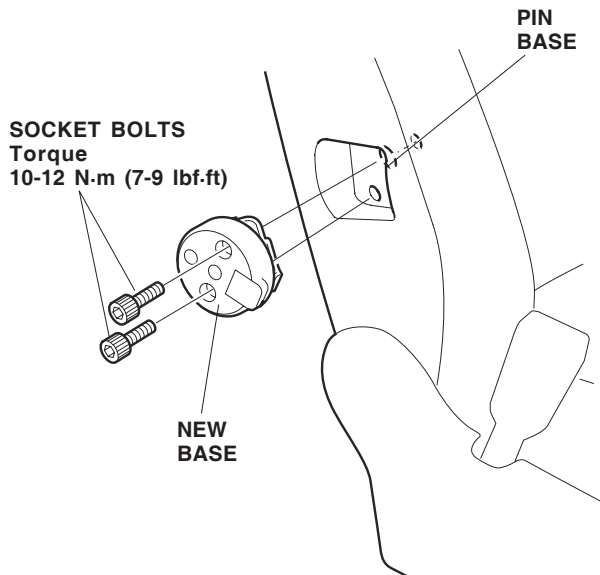

8. Insert the armrest into the holes in the base and push on it until it clicks into position. The white recessed portion of the push knob should be visible.

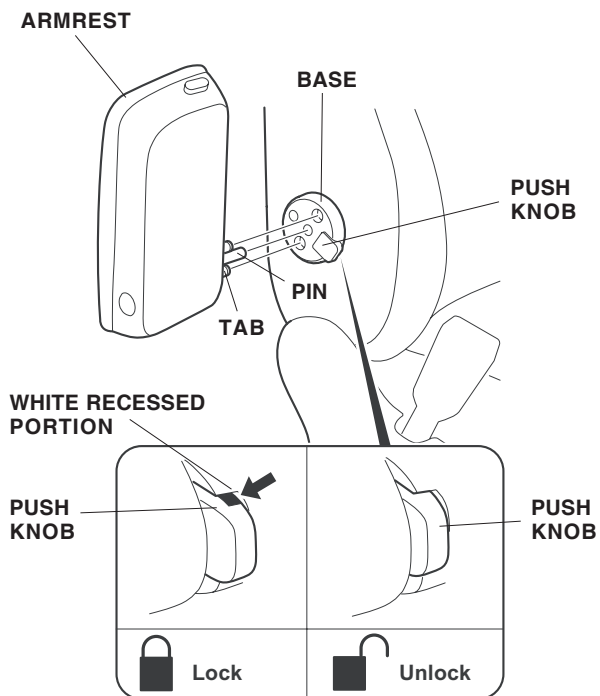

9. Check that the armrest operates properly by moving it up and down with your hand.
10. To release the armrest lock, press on the push knob and pull out on the armrest.
11. Put the armrest owner's manual in the glove box.