



# INSTALLATION INSTRUCTIONS

Accessory

**AUTOMATIC DAY/NIGHT MIRROR WITH COMPASS  
(EX, EX-L, EX-L NAVI)**

Application

**2006 ACCORD  
2- AND 4-DOOR**

Publications No.

**All 30199**

Issue Date

**AUG 2005**

## PARTS LIST

**Automatic Day/Night Mirror Kit  
P/N 08V03-SDA-100B**

Day/night mirror

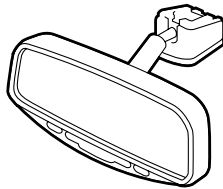

Mirror spring



Owner's manual

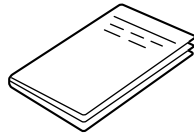

**Attachment Kit (sold separately)  
P/N 08V03-SDA-101A**

Short upper mirror cover  
(Use on all EX vehicles)

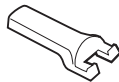

Short lower mirror cover  
(Use on all EX vehicles)

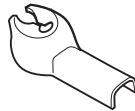

Long upper mirror cover  
(not used)

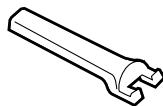

Long lower mirror cover  
(not used)

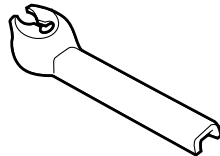

Mirror harness



2 EPT Sealers

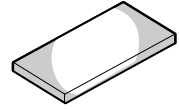

5 Wire ties



## TOOLS AND SUPPLIES REQUIRED

Phillips screwdriver

Isopropyl alcohol

Small flat-tip screwdriver

Scissors

Ratchet

8 mm Socket

Eye protection (face shield, safety goggles, etc.)

Tape measure

Drill

7 mm Drill bit

Long-nose pliers

## Illustration of the Day/Night Mirror Installed on the Vehicle

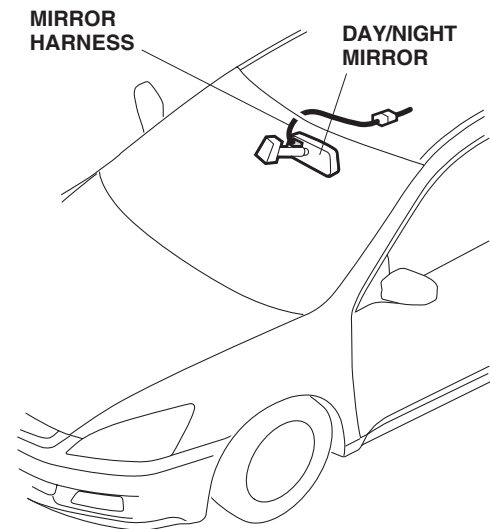

## INSTALLATION

**Customer Information:** The information in this installation instruction is intended for use only by skilled technicians who have the proper tools, equipment, and training to correctly and safely add equipment to your vehicle. These procedures should not be attempted by "do-it-yourselfers."

1. Make sure you have the anti-theft code for the radio, then write down the radio station presets.
2. Disconnect the negative cable from the battery.
3. Remove the left and right lenses from the roof console (six retaining tabs).

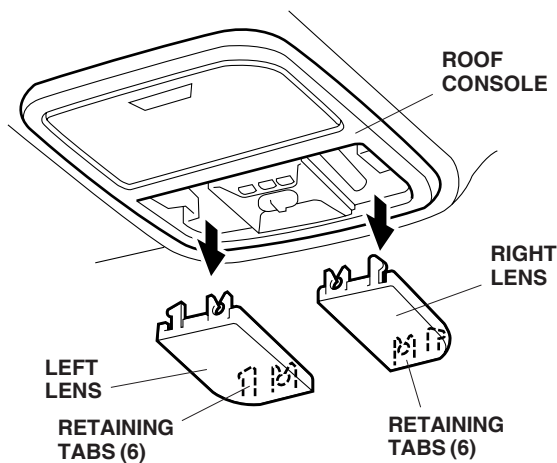

4. Remove the roof console (four bolts, and unplug the two connectors).

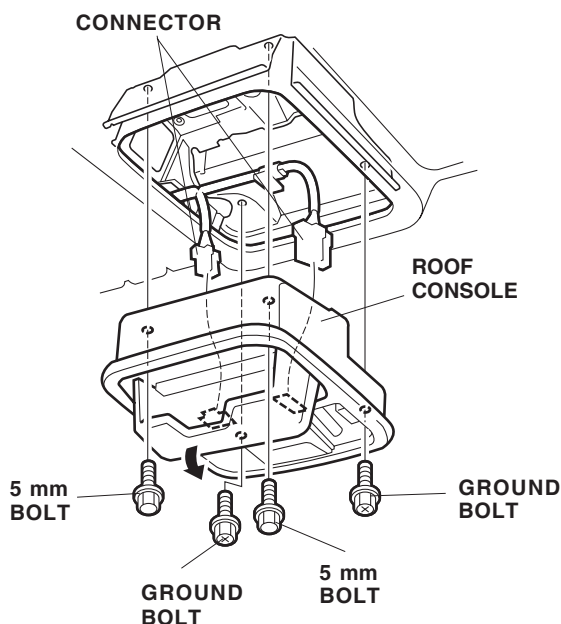

5. Remove the rearview mirror from the holder by rotating the stay 90° clockwise.

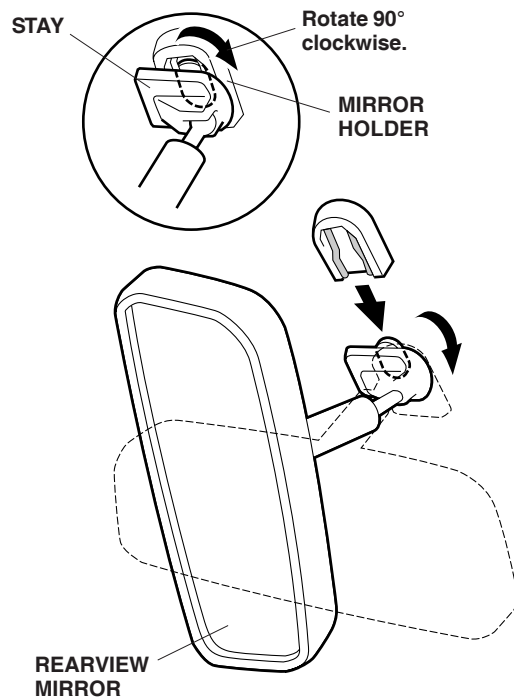

6. Replace the mirror spring. Slide the day/night mirror stay onto the mirror holder, then turn the mirror stay counterclockwise as shown.

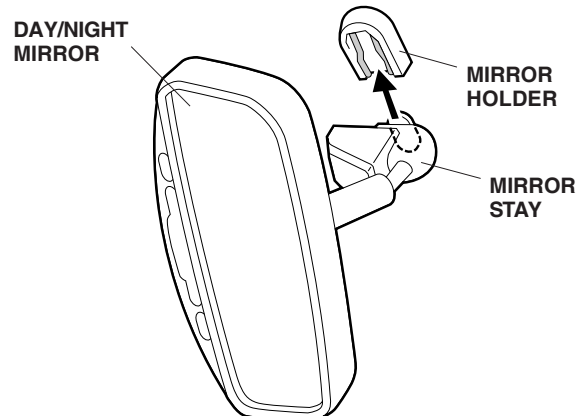
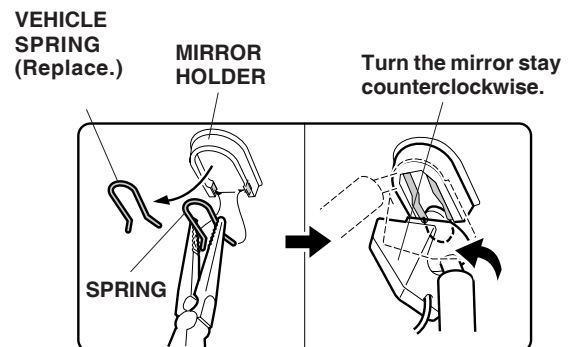

7. Plug the mirror harness 7-pin connector into the rear of the mirror, then route the 3-pin connector up and out through the roof liner as shown.

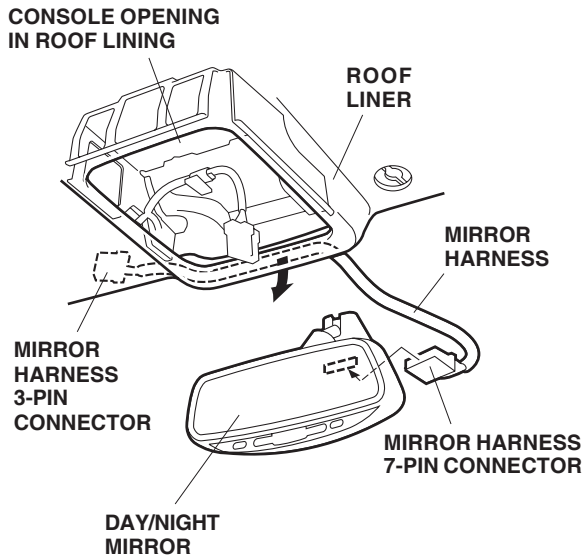

8. On the lower mirror cover, measure and cut off the ribs as shown.

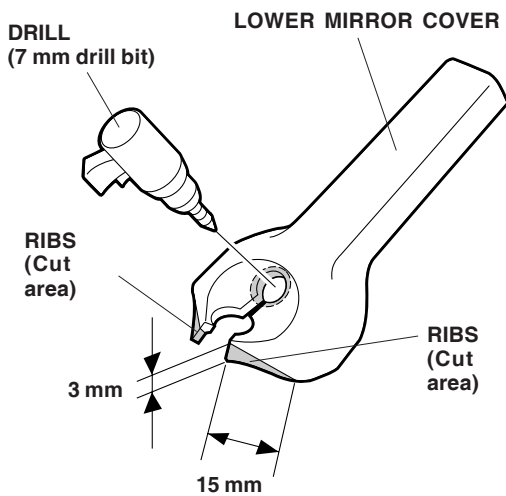

9. While wearing eye protection, drill a 7 mm hole through the existing hole on the lower cover as shown.

10. Measure and mark the mirror harness 110 mm from the 7-pin connector. Slide the end of the upper cover into the lower cover, then route the mirror harness through the grooves in the covers. Attach the lower cover to the mirror stay, and slide the upper cover to the edge of the roof liner.

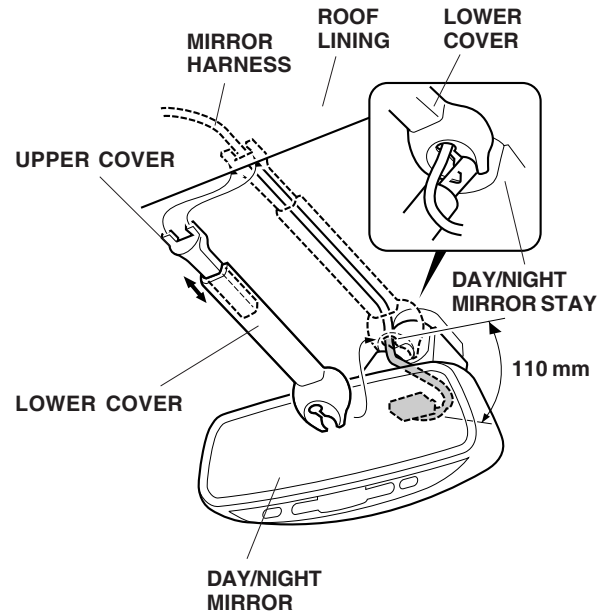

11. Remove the dummy connector from the vehicle harness 3-pin connector, then connect the vehicle harness 3-pin connector to the mirror harness 3-pin connector.

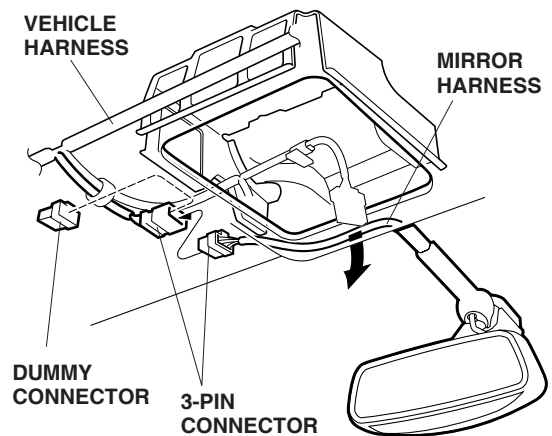

- Using isopropyl alcohol, thoroughly clean the area where the EPT sealers will attach.

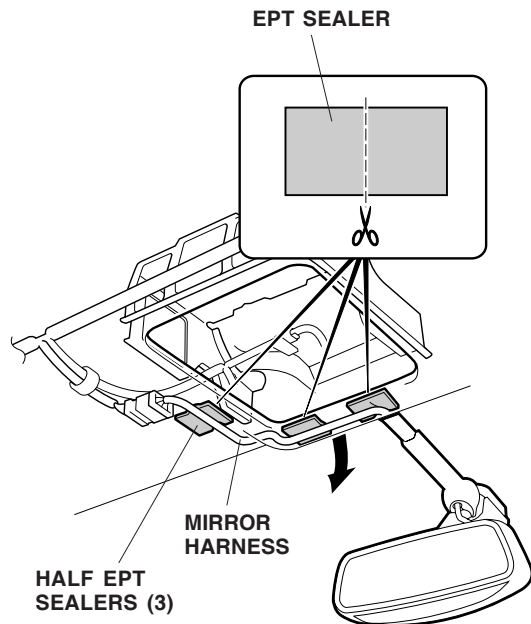

- Using scissors, cut the two EPT sealers in half.
- Attach the mirror harness to the roof liner with three pieces of the EPT sealer in the areas shown.

- Check that all wire harnesses and cables are routed properly and that all connectors are plugged in.
- Reinstall all removed parts.
- Reconnect the negative cable to the battery.
- Enter the customer's radio anti-theft code, and reset the radio station presets.
- Reset the clock.
- Check the operation of the automatic day/night mirror according to the owner's manual supplied.

**NOTE:** Whenever the battery is disconnected, the driver's window AUTO function is disabled.

- Start the engine. Push down on the driver's window switch until the window is fully open.
- Pull up on the driver's window switch fully to close the window completely, then hold the switch for 2 seconds.
- Check the window AUTO function by opening and closing the window with the driver's window switch.