



INSTALLATION INSTRUCTIONS

Accessory FOG LIGHT P/N 08V31-SDA-101	Application 2006 ACCORD HYBRID	Publications No. All 31220
		Issue Date OCT 2005

NOTE: The outside temperature gauge cannot be installed in a vehicle with accessory fog lights.

PARTS LIST

Right fog light

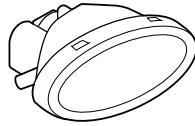

Left fog light



Right bracket A



Left bracket A



Right bracket B



Left bracket B



Right trim

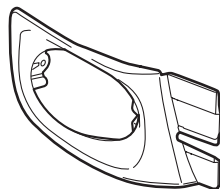

Left trim

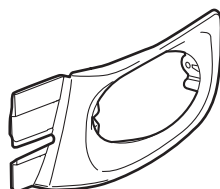

Fog light harness

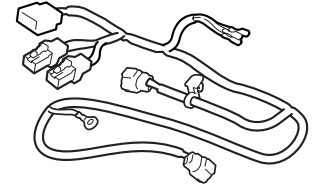

Switch harness

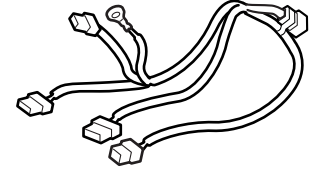

Switch

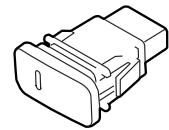

Template A

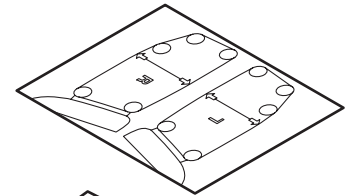

Template B

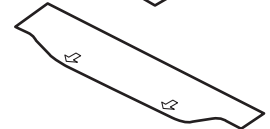

Relay (black)

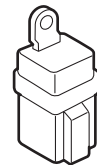

Relay (gray)

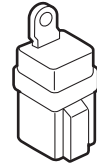

Fuse label

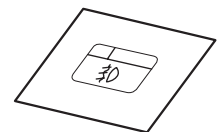

4 Self-tapping screws,
5 x 12 mm



2 Step-screws,
(with rubber)



2 Step-screws



2 Ground bolts



Washer



2 Washer-bolts



3 Washer-screws



25 Long wire ties

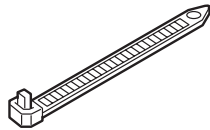

3 Short wire ties

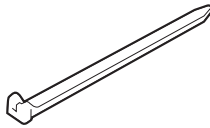

Relay bracket

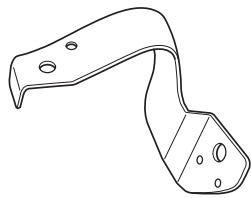

4 Self-tapping screws,
4 x 16 mm



Fuse (20A)



Flange nut



Corrugated tube

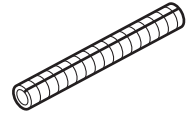

TOOL AND SUPPLIES REQUIRED

#2 Phillips screwdriver

Small flat-tip screwdriver

Felt-tip pen

10 mm Combination wrench

10 mm Socket

Ratchet

Measure

3 mm and 7 mm Drill bits

Eye protection (face shield, safety goggles, etc.)

File

Diagonal cutters

20 mm Hole saw

Drill

Masking tape

Pushpin

Drill stop

Scissors

Hacksaw blade

Illustration of the Fog Lights Installed on the Vehicle

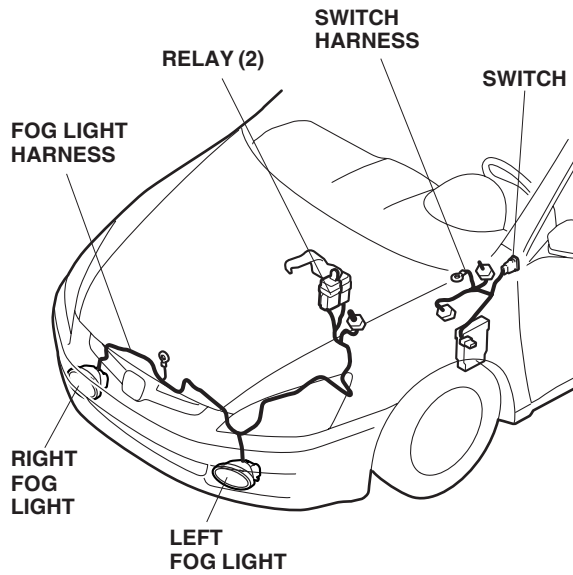

INSTALLATION

Customer Information: The information in this installation instruction is intended for use only by skilled technicians who have the proper tools, equipment, and training to correctly and safely add equipment to your vehicle. These procedures should not be attempted by “do-it-yourselfers.”

1. Make sure you have the anti-theft code for the radio, then write down the radio station presets.
2. Disconnect the negative cable from the battery.

Installing Fog Lights

3. Install the left trim to left bracket A with two 4 x 16 mm self-tapping screws.

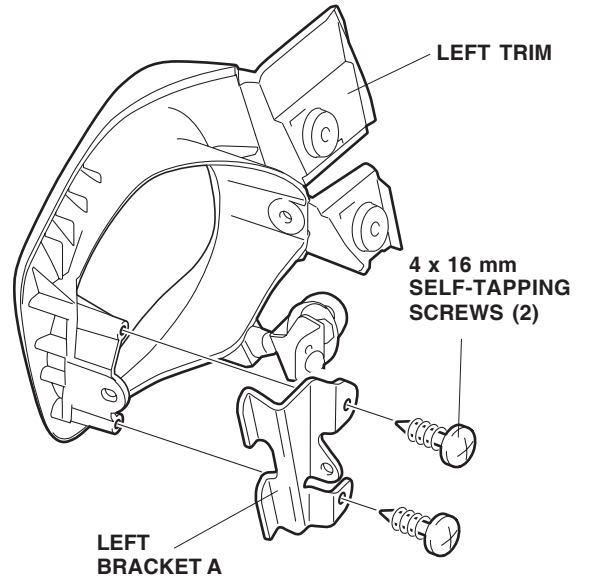

4. Install the left fog light to the left trim with the one step-screw (with rubber), step-screw, and washer-screw.

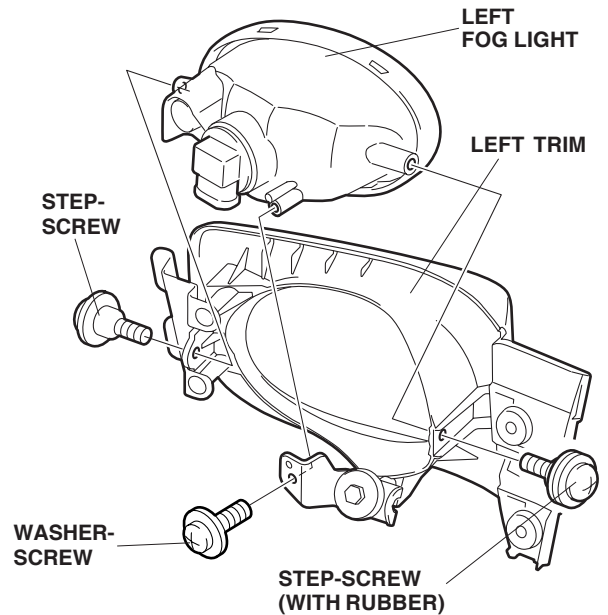

5. Repeat steps 3 and 4 to install the right fog light.

Cutting the Front Bumper.

- Using scissors, cut out template A. Position template A on the front bumper as shown, and mark the bumper at each of the two marks indicated on template A with a felt-tip pen.

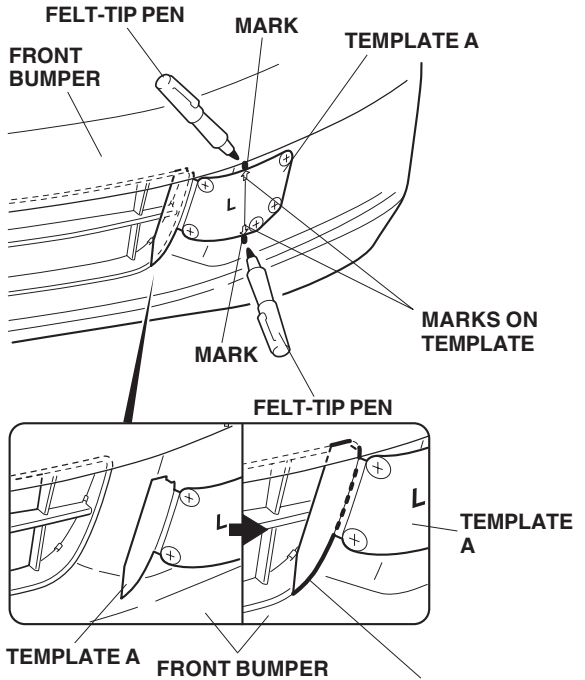

Align the end of the template with the end of the bumper grille

- Remove template A.

- Align template B with the marks you just made, and mark the bumper at the two marks indicated on template B with a felt-tip pen. Remove template B.

If equipped with a front spoiler, measure and cut off template B, and align template B on the front bumper.

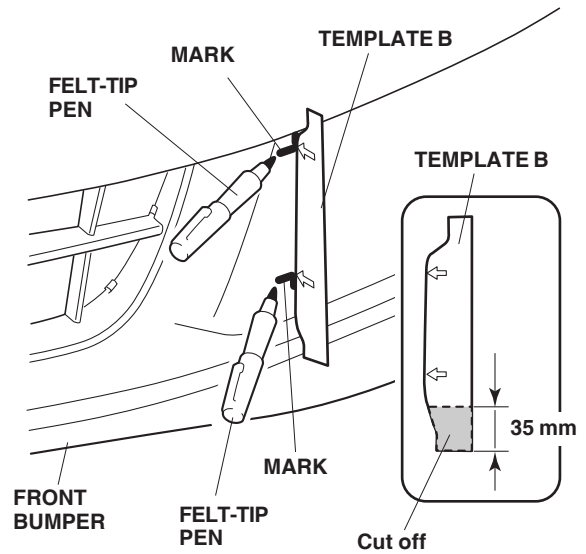

- Align template A with the marks you just made. Tape template A to the bumper with strips of masking tape.

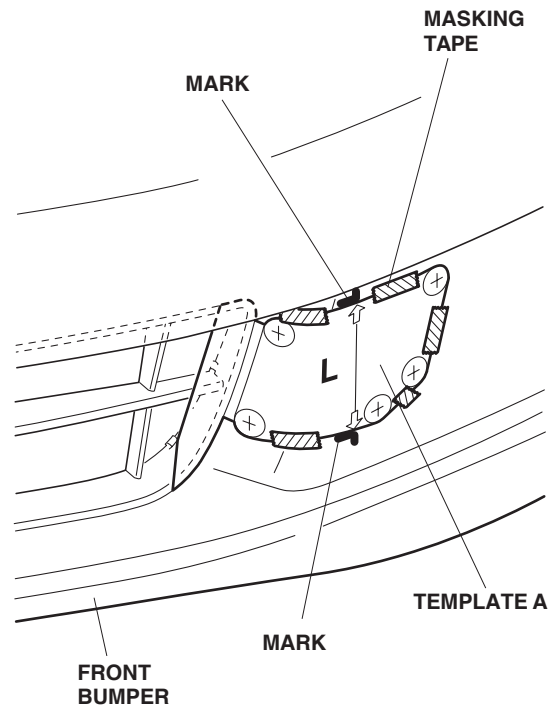

- Using a pushpin, mark the front bumper at the centers of the five marks indicated on template A.

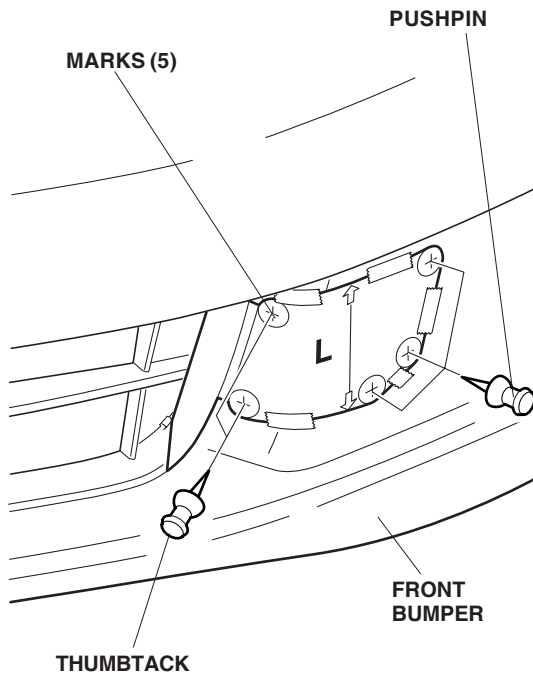

- Using a felt-tip pen, mark the front bumper along outer edge of template A.

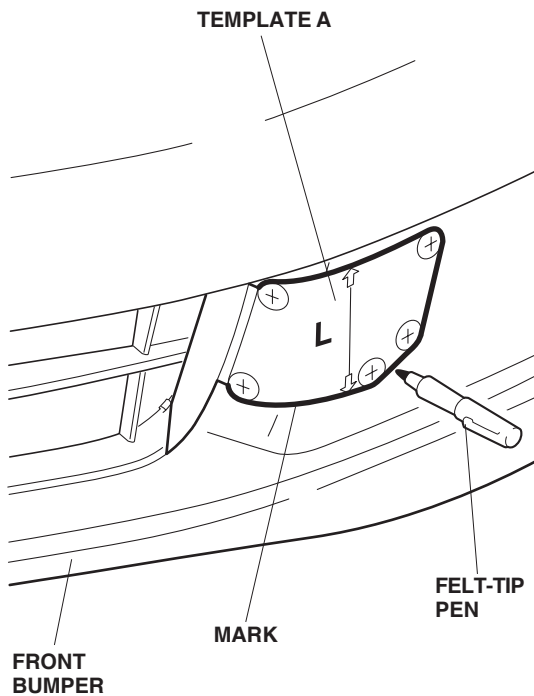

- Remove template A.

- To prevent damage to the front bumper, apply masking tape around the fog light opening.

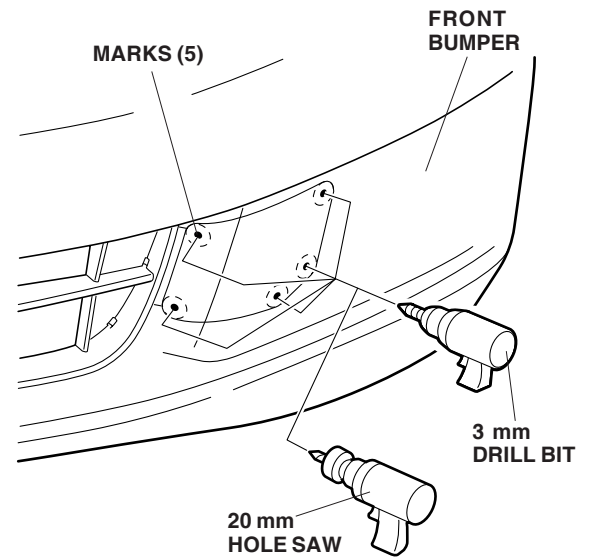

- While wearing eye protection, drill a 20 mm hole through each of the five marked locations using a 20 mm hole saw. Start with a 3 mm drill bit, and finish with a 20 mm hole saw.
- Using a straight edge, mark between the two inboard holes.

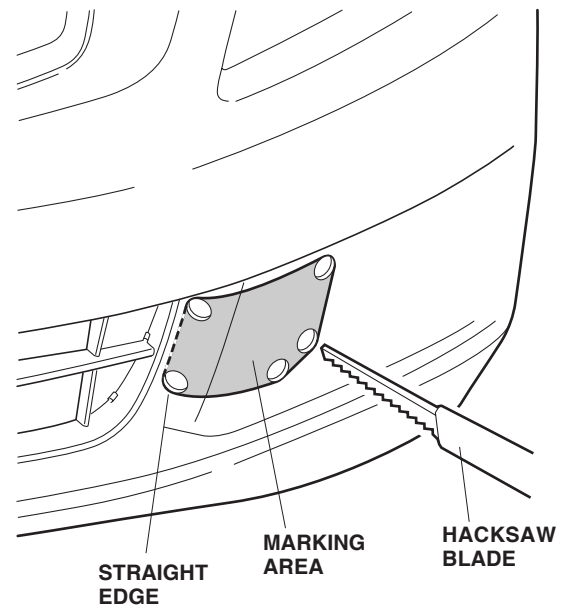

- Using a hacksaw blade, cut out the front bumper along the lines made in steps 11 and 15. Remove any burrs from the edge of the hole with a file.

- Hook the fog light tabs on bracket A under the edge of the bumper hole. With the tabs on bracket A hooked to the edge of the bumper hole, position the left fog light on the front bumper as shown. Open the two screw covers. Using a felt-tip pen, mark the trim at the center of each hole concealed under the screw cover as shown.

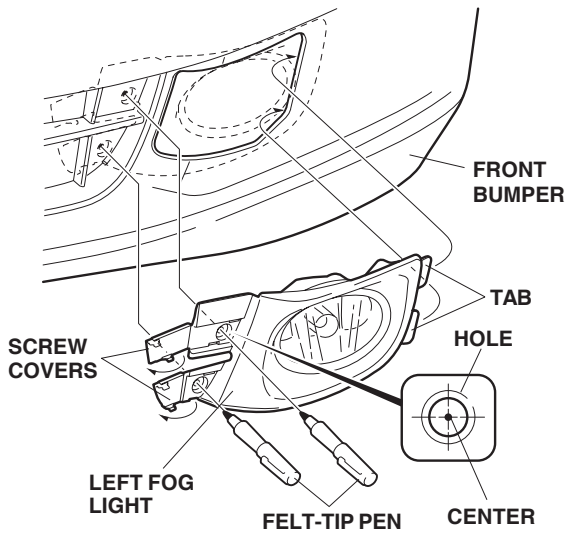

- Remove the left fog light.
- While wearing eye protection, drill a 7 mm hole through the bumper at each of the two marks made in step 17. First drill with a 3 mm bit, and finish with a 7 mm bit. Remove any burrs from the edges of the holes.

NOTE: To prevent damaging the vehicle frame, use a drill stop around the drill bit 10 mm from the end.

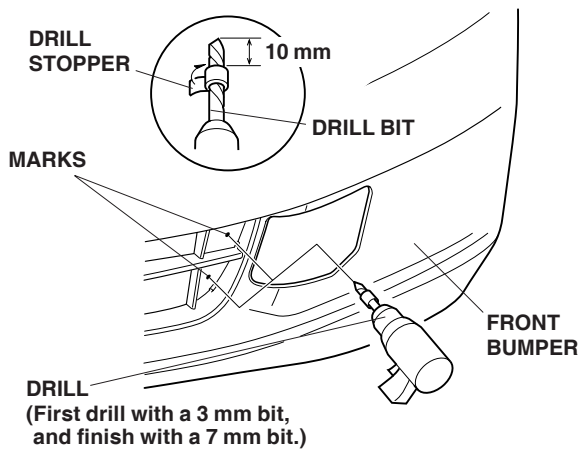

- Repeat steps 6 through 19 to install the right fog light.

Routing the Fog Light Harness

- Open the hood. Remove the radiator cover (ten clips and four retaining tabs).

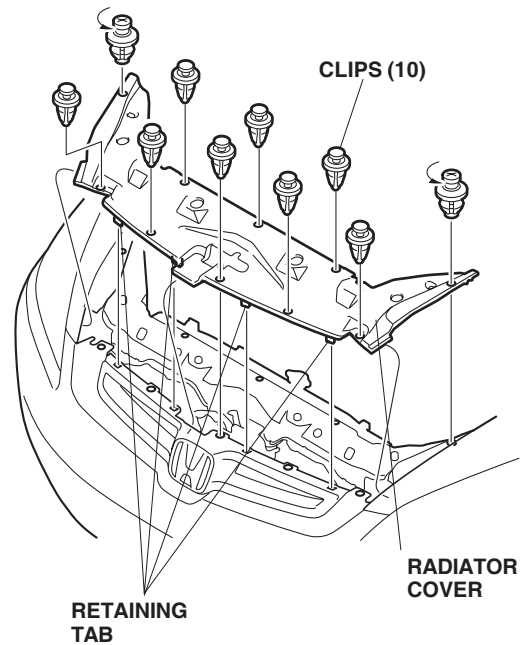

- Remove the hood latch cover (one clip).

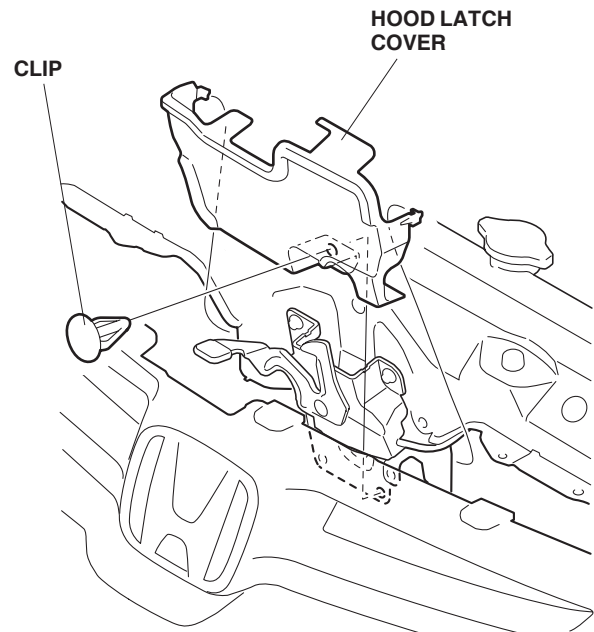

23. Remove the air duct cover (two clips and pull it out toward you). Remove the air duct cover by pulling it out toward you.

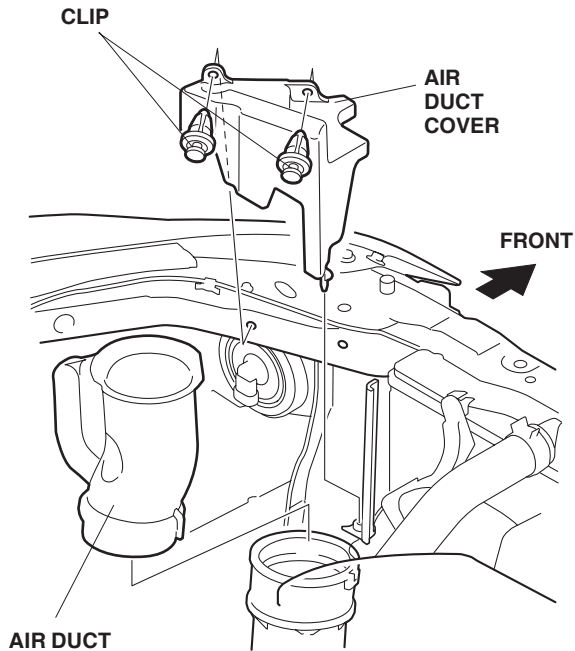

24. Route the fog light harness 2-pin connector through the front bulkhead and alongside the vehicle harness.

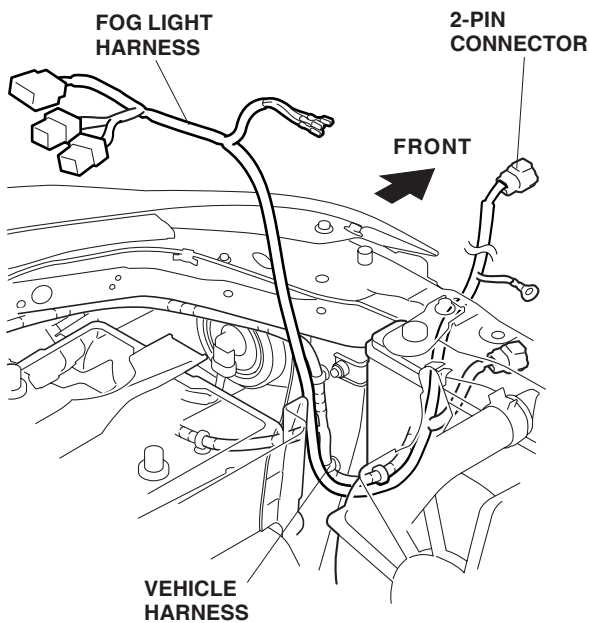

25. Route the ground terminal end of the fog light harness alongside the vehicle harness across the front bulkhead to the right side of the vehicle.

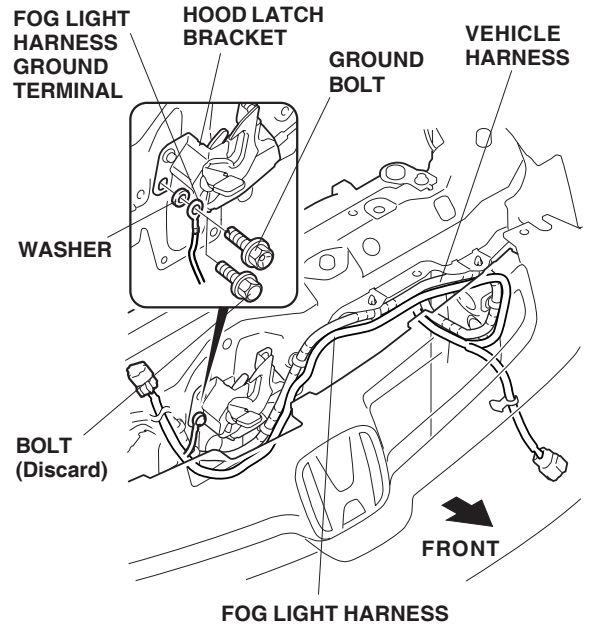

26. Remove and discard the lower bolt that secures the hood latch bracket. Using one ground bolt and the washer supplied, attach the fog light harness ground terminal to the hood latch bracket.

27. On left side of vehicle, secure the fog light harness to the vehicle harness with five wire ties in the areas shown. Push the fog light harness clip into the hole in the body panel.

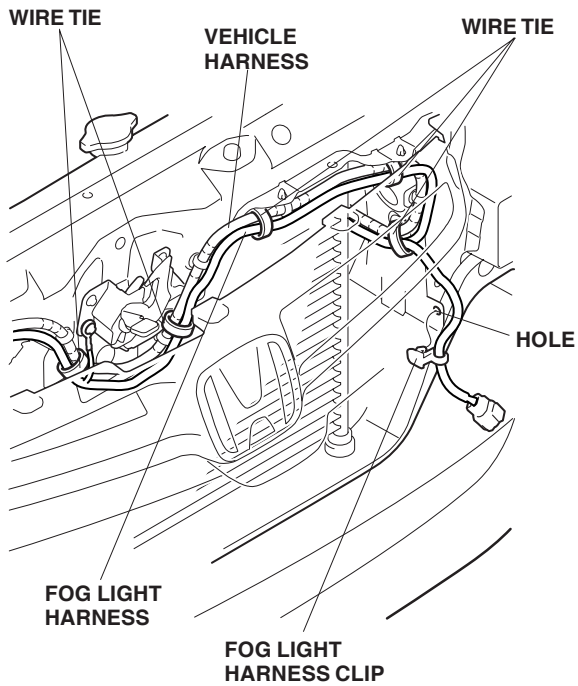

28. On the right side of vehicle, secure the fog light harness to the vehicle harness with four wire ties.

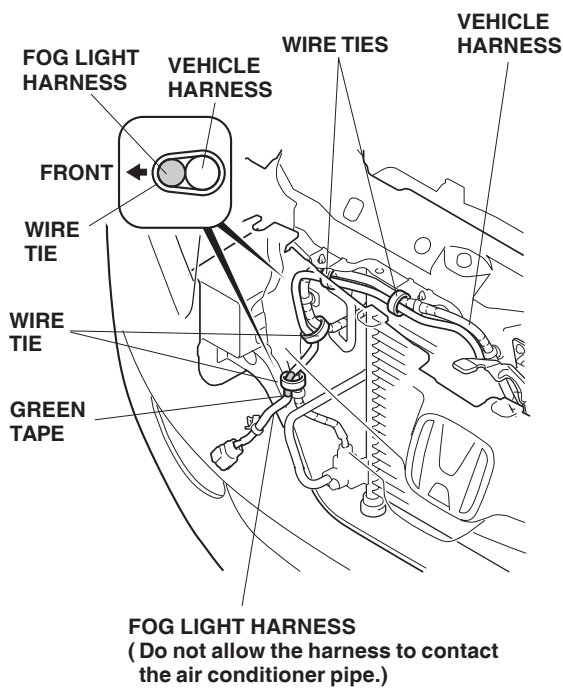

29. Insert the tab from left bracket B through the left fog light opening, and attach bracket B to the grille hole in the bumper grille.

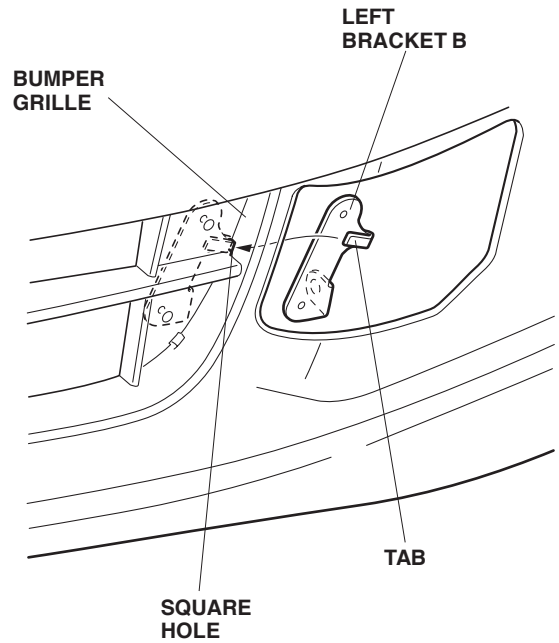

30. Connect the left fog light harness 2-pin connector to the left fog light, and hook the tabs on bracket A under the edge of the bumper hole. Open the screw covers, and attach the left fog light to the front bumper with two 5 x 12 mm self-tapping screws. Close the screw covers.

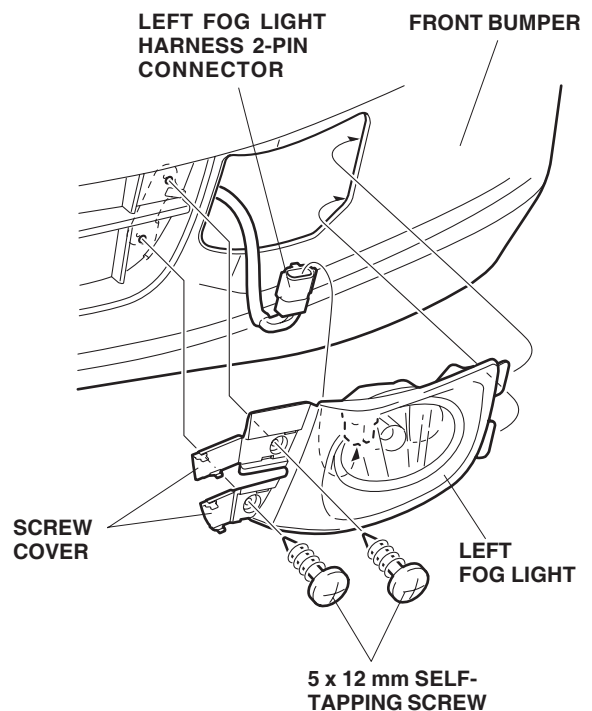

31. Insert the tab from right bracket B through the right fog light opening, and attach bracket B to the grille hole in the bumper grille.

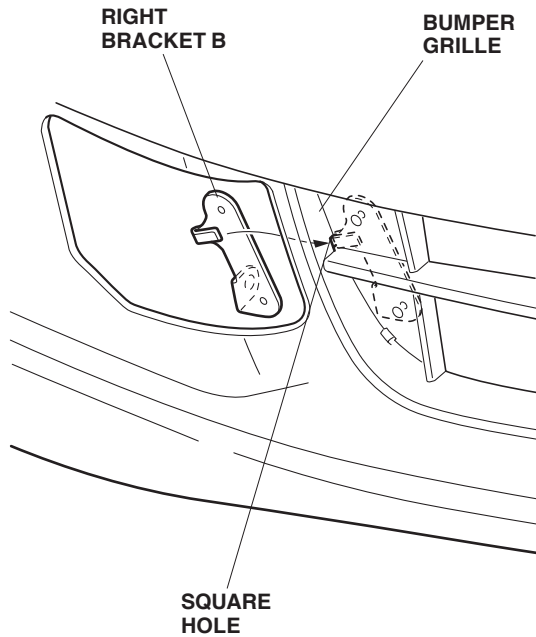

32. Attach the right fog light harness wire connector to the right fog light with the washer-screw.

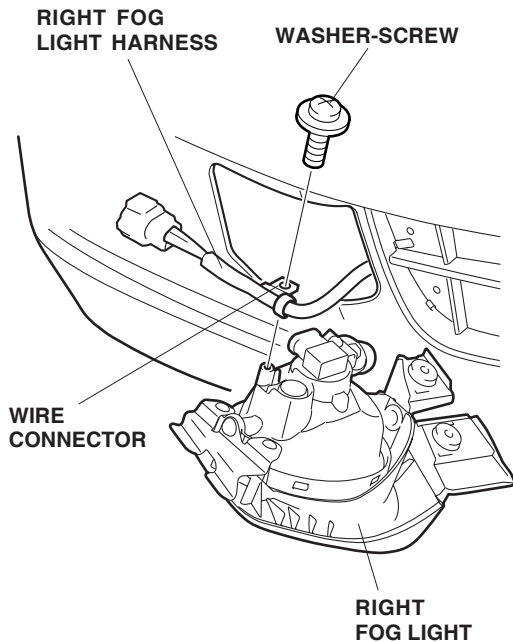

33. Connect the right fog light harness 2-pin connector to the right fog light, and hook the tabs on bracket A under the edge of the bumper hole. Open the screw covers, and attach the right fog light to the front bumper with the two 5 x 12 mm self-tapping screws. Close the screw covers.

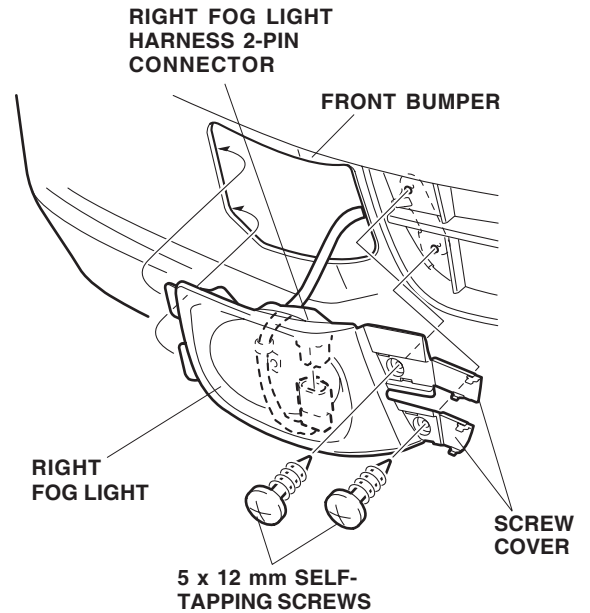

34. Remove the auxiliary under-hood fuse/relay box B (one retaining tab).

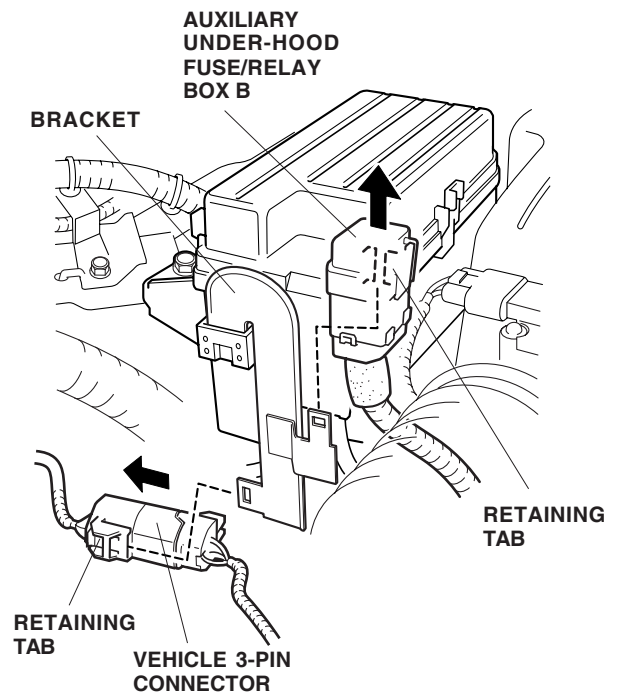

35. Remove the vehicle 3-pin connector (one retaining tab).

36. Remove the bracket from the under-hood fuse/relay box (one retaining tab).

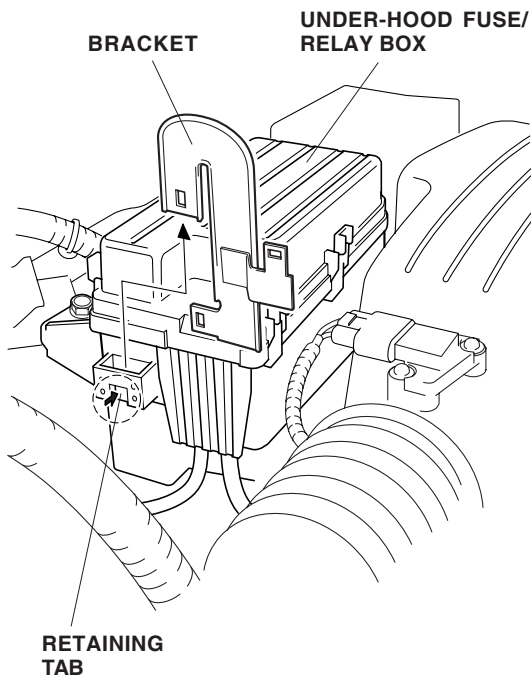

37. Remove the vehicle wire tie from the bracket (one retaining tab).

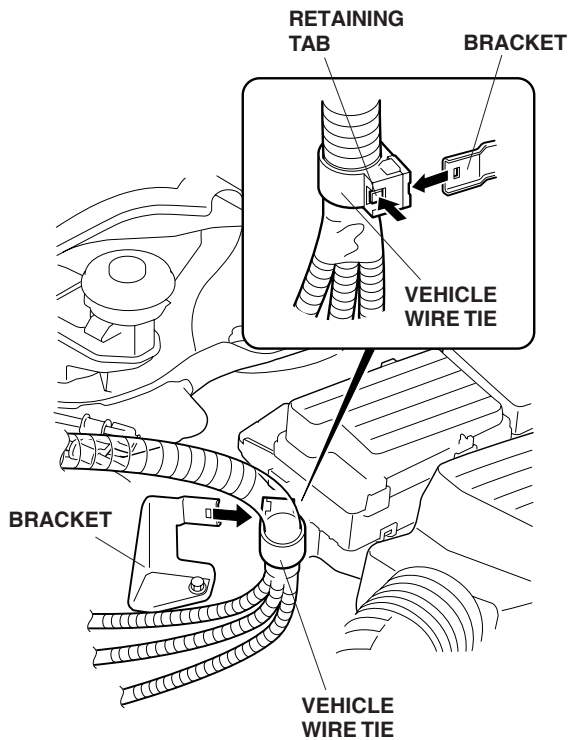

38. Remove the under-hood fuse/relay box cover (four retaining tabs).

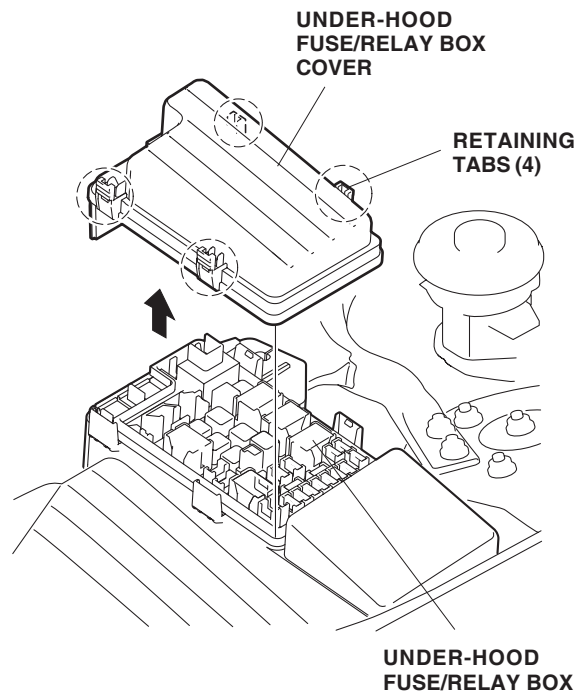

39. Remove the two vehicle harnesses (two bolts). Disconnect the negative cable first from the battery terminal.

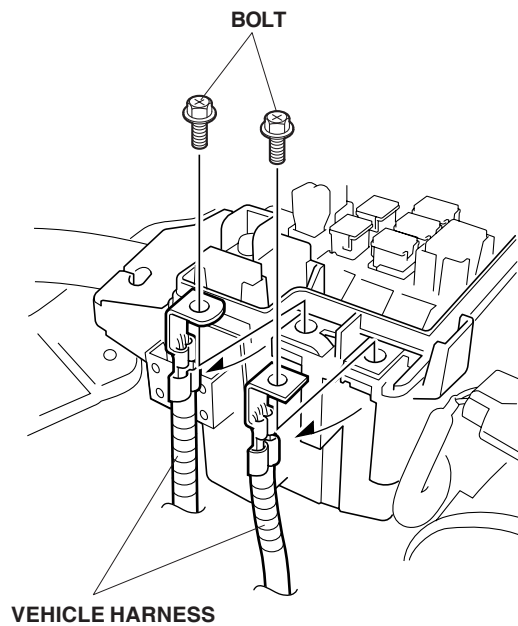

40. Remove the two bolts that secure the under-hood fuse/relay box.

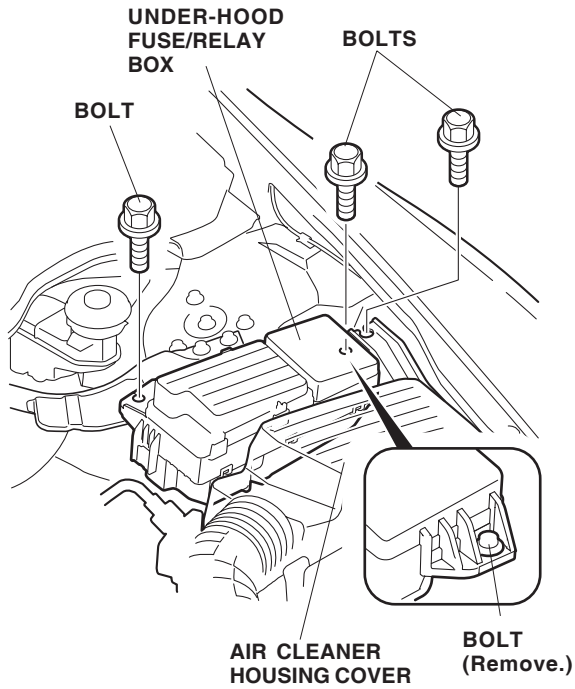

41. Remove the bolt that fastens the air cleaner housing cover.

42. Release the six retaining tabs, and separate the under-hood fuse/relay box under cover.

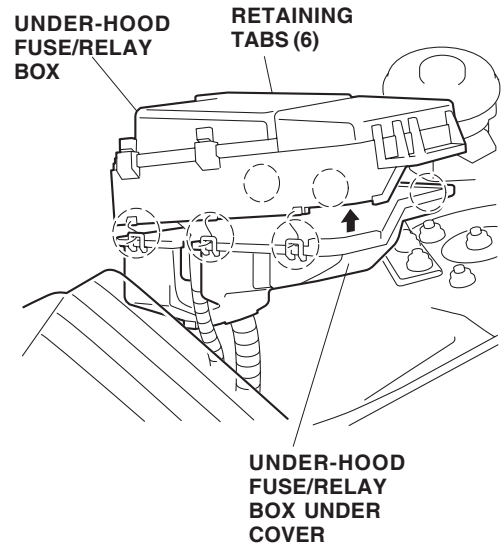

43. Raise the fuse/relay box.

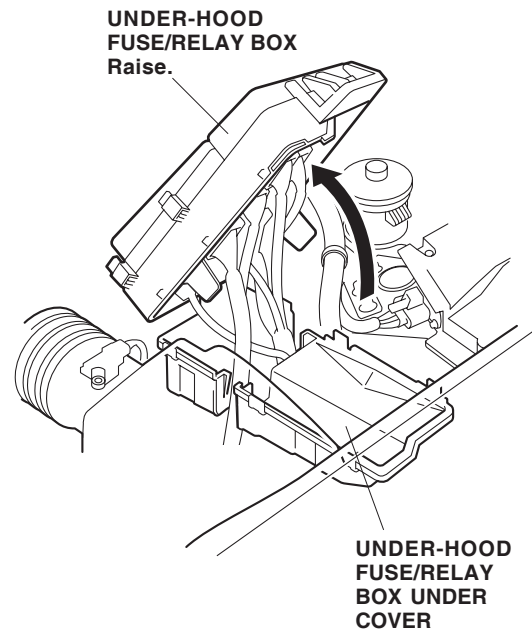

44. Lift the air cleaner housing cover up, and route the other end of the fog light harness toward the engine alongside the vehicle harness.

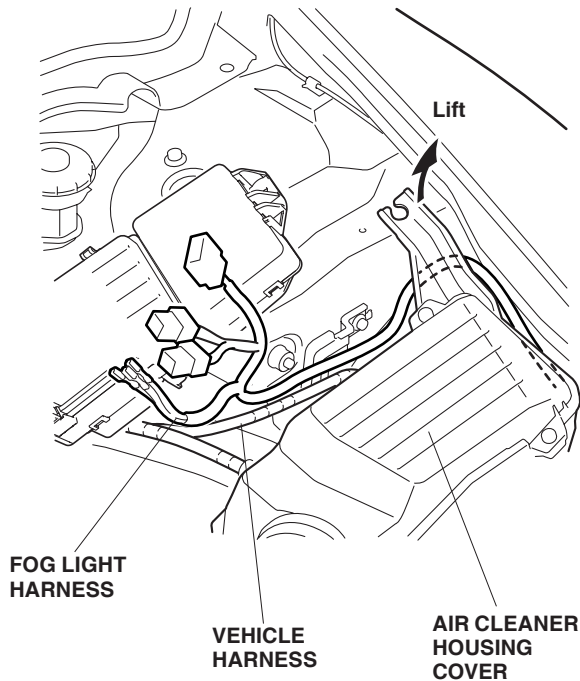

45. Unplug the vehicle 14-pin and 20-pin connectors from the under-hood fuse/relay box. Release the lock on the vehicle 14-pin connector, and push the fog light harness white/green and red/green wire terminals into the vehicle 14-pin connector. Reattach the lock on the 14-pin connector.

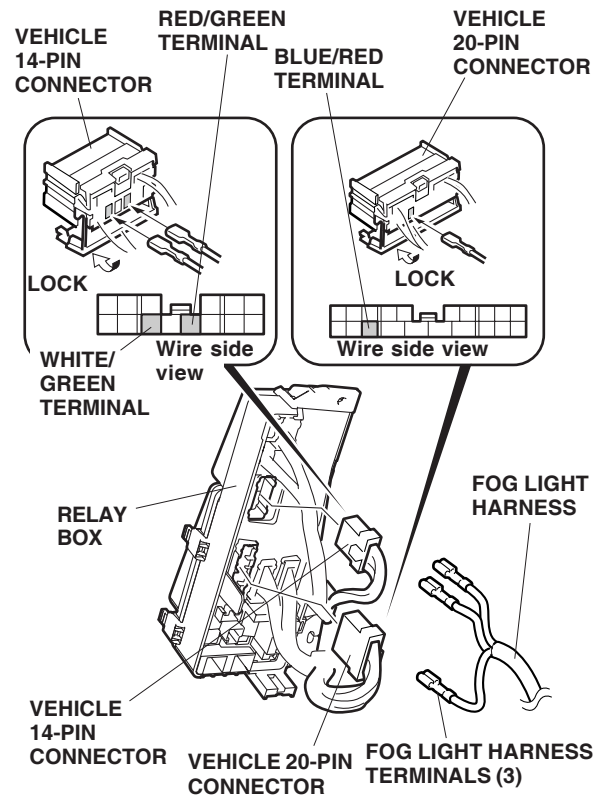
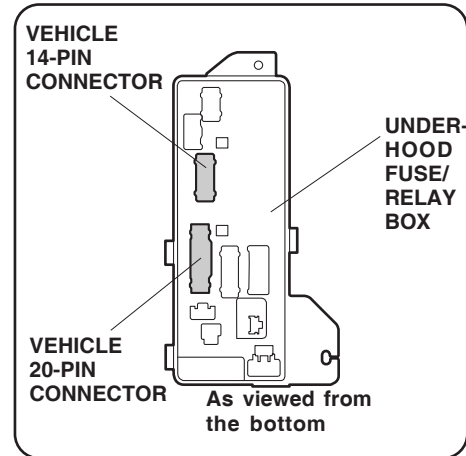

46. Release the lock on the vehicle 20-pin connector, and push the fog light harness blue/red wire terminal into the vehicle 20-pin connector. Reattach the lock on the 20-pin connector.
47. Plug the vehicle 14-pin and 20-pin connectors into the under-hood fuse/relay box.

48. Secure the fog light harness to the vehicle harness with one wire tie in the area shown.

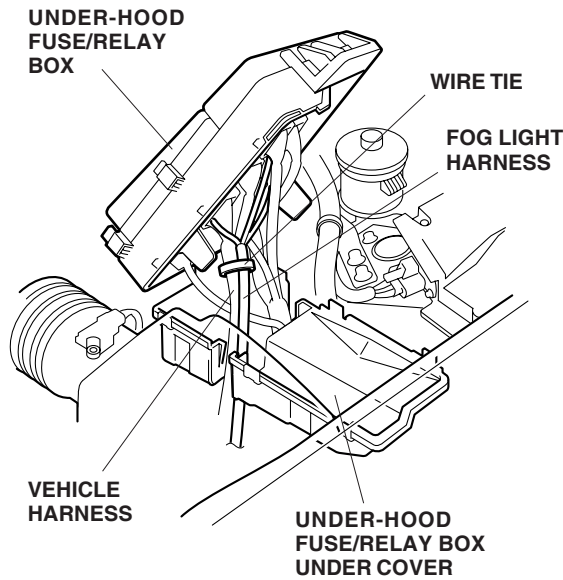

49. Reinstall the under-hood fuse/relay box under cover. Be careful not to pinch the wires.
50. Wrap the corrugated tube around the vehicle harness and secure with the three short wire ties.

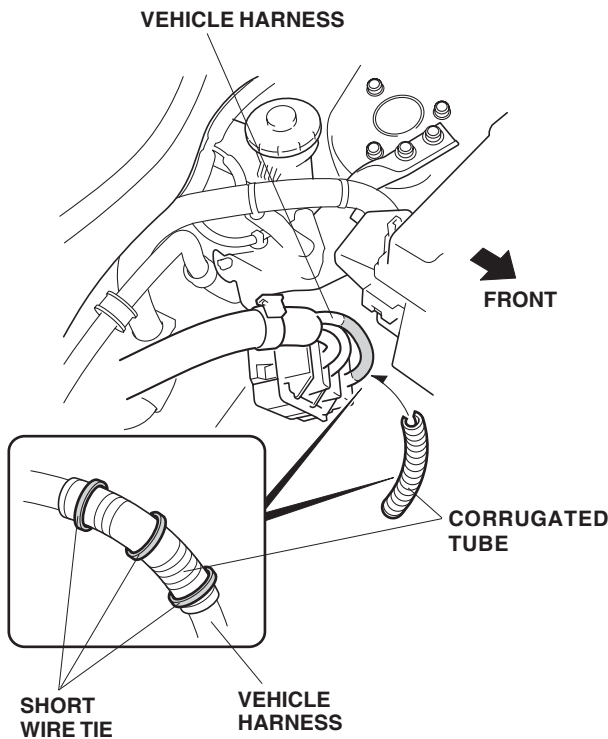

51. Reinstall the vehicle wire tie removed in step 37.

52. Under the under-hood fuse/relay box, locate the vehicle 3-pin connector blue-taped to the vehicle harness, and remove the blue tape to free the connector. Connect the fog light harness 3-pin connector into the 3-pin connector you just freed. Secure the fog light harness to the vehicle harness with four wire ties in the area shown.

A/T Model:

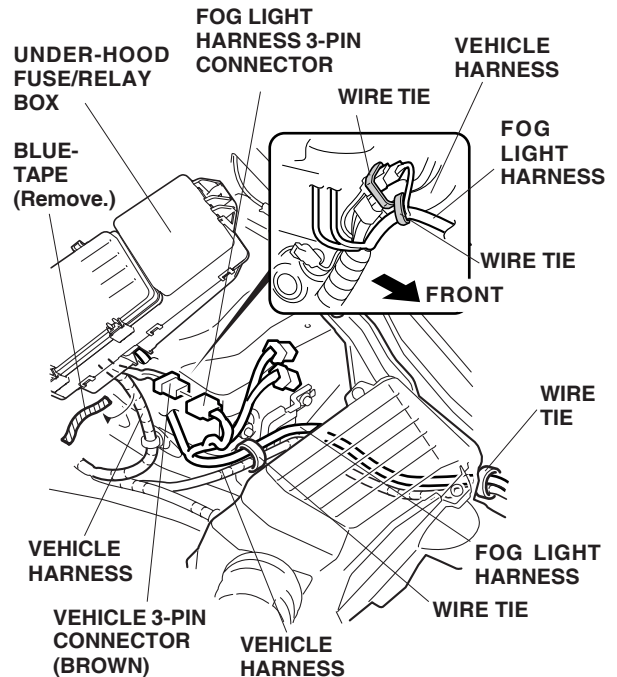

M/T Model:

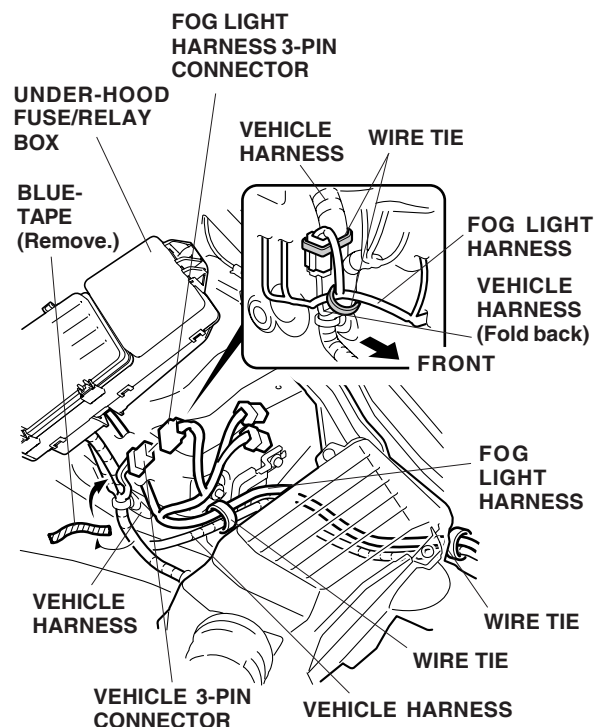

NOTE: If the 3-pin connector is already used by another accessory, locate the 3-pin connector taped to that other accessory harness. Remove the tape and the dummy connector from the other accessory harness. Plug the fog light harness 3-pin connector into the other accessory harness.

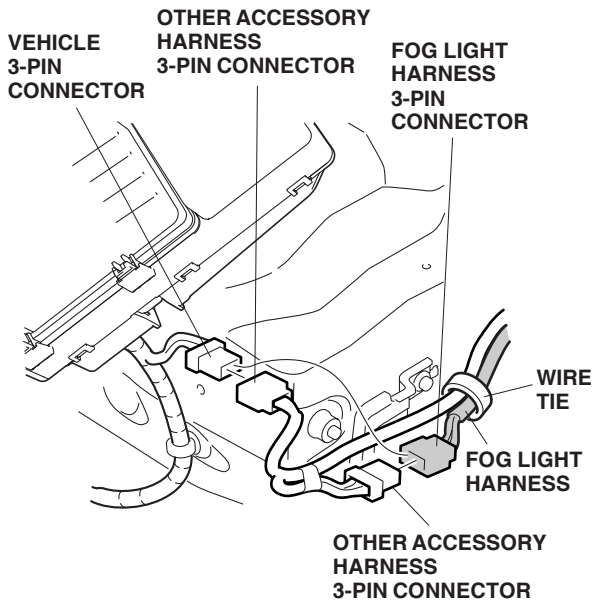

53. Install the relays (black and gray) to the relay bracket with one washer-bolt and one flange nut.

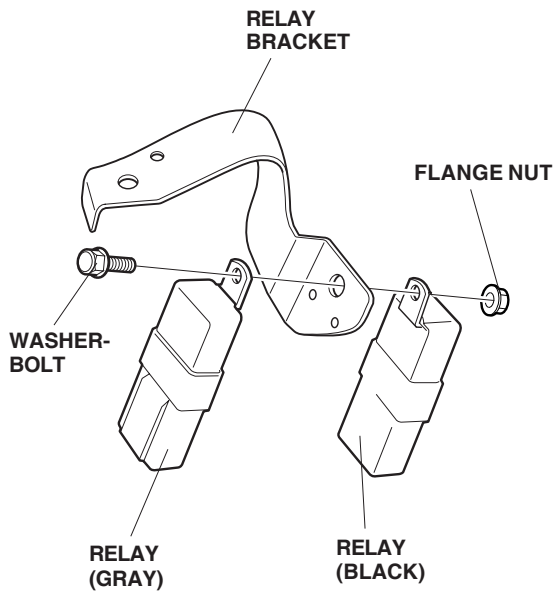

54. Plug the two fog light harness 4-pin connectors into the relays. Plug the blue connector into the gray relay and the brown connector into the black relay.

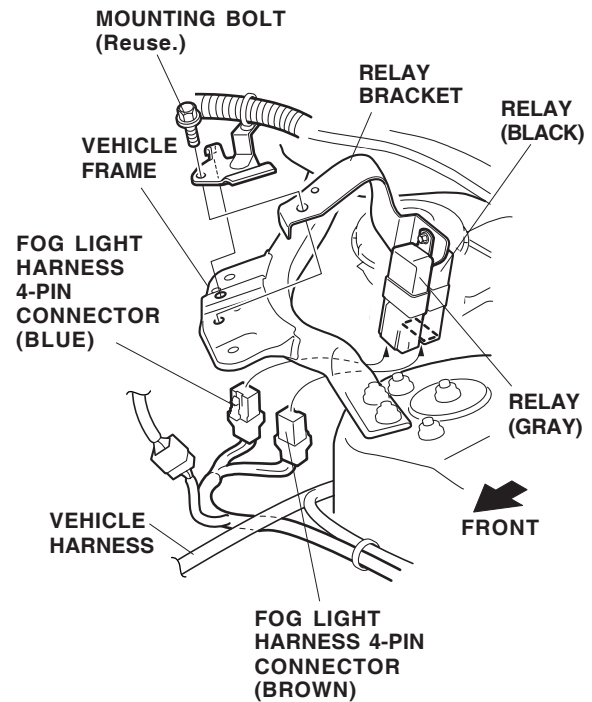

55. Remove the mounting bolt that secures the vehicle bracket, and attach the relay bracket with this bolt.

56. Secure the fog light harness to the vehicle harness with three wire ties in the areas shown.

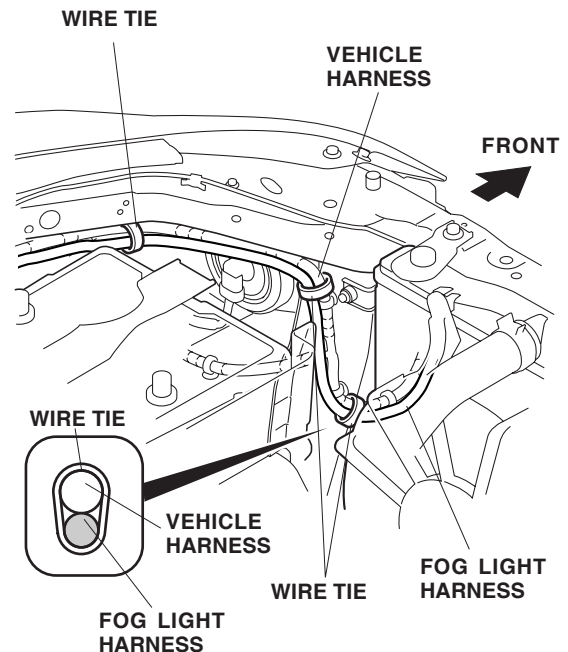

57. Install the 20A fuse (provided) into the No.10 slot of the under-hood fuse/relay box.

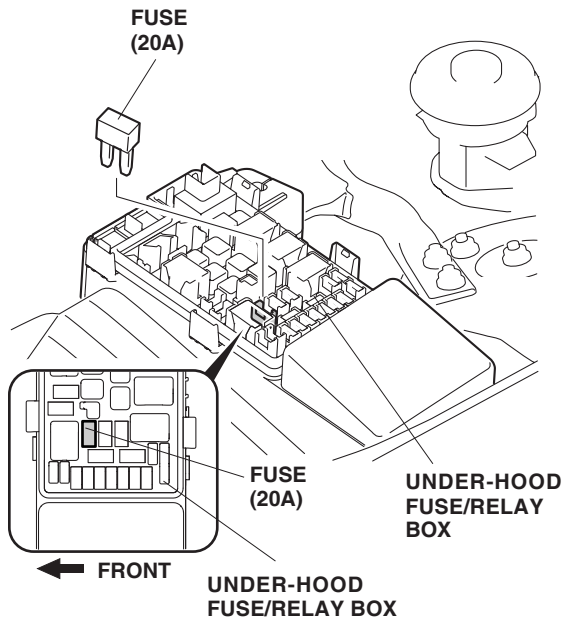

58. Attach the 20A fuse label over the No.10 spot of the under-hood fuse/relay box cover. Reinstall the under-hood fuse/relay box cover.

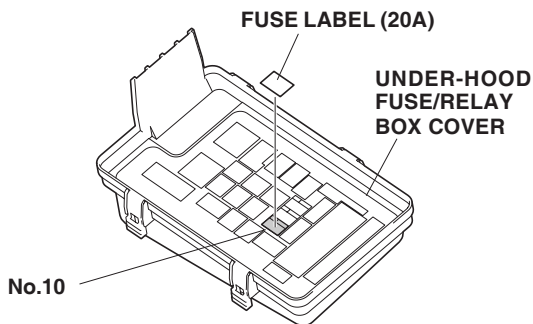

Routing the Switch Harness

59. Remove the driver's dashboard lower cover:
- Remove the one self-tapping screw.
 - Release the four clips on the left side first by pulling out on the driver's dashboard lower cover.
 - After releasing the four clips, insert the flat-tip screwdriver between the clip and the dashboard frame. Gently twist the screwdriver to release the clip.
 - Release the two clips on the right side.
 - Unplug the vehicle connector, and remove the lower cover.

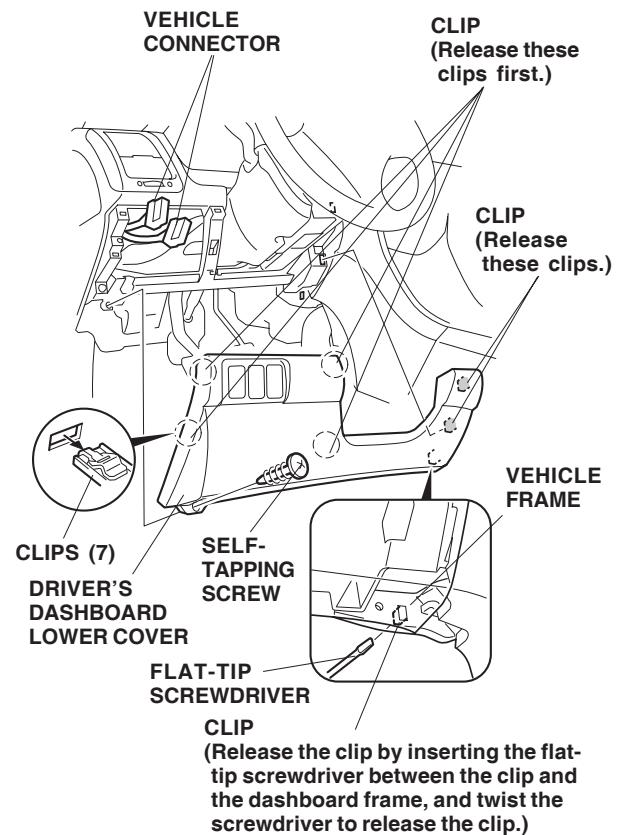

60. If equipped, remove the driver's dashboard under cover (three clips, one pin, and one holder).

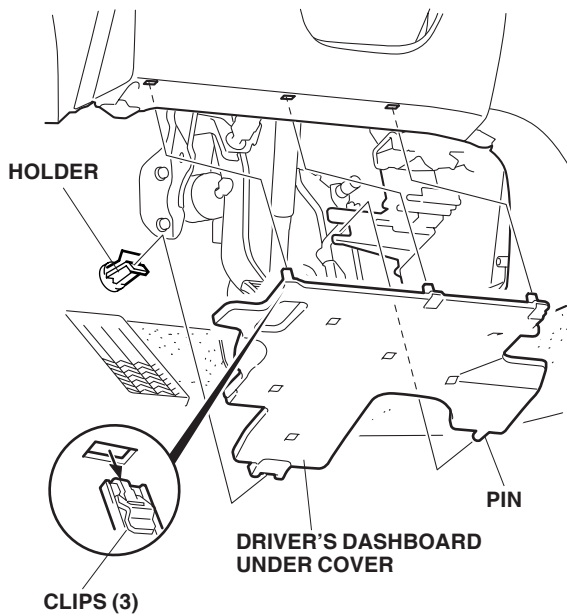

61. Plug the switch harness 6-pin connector into the 6-pin connector connection position of the under-dash fuse/relay box.

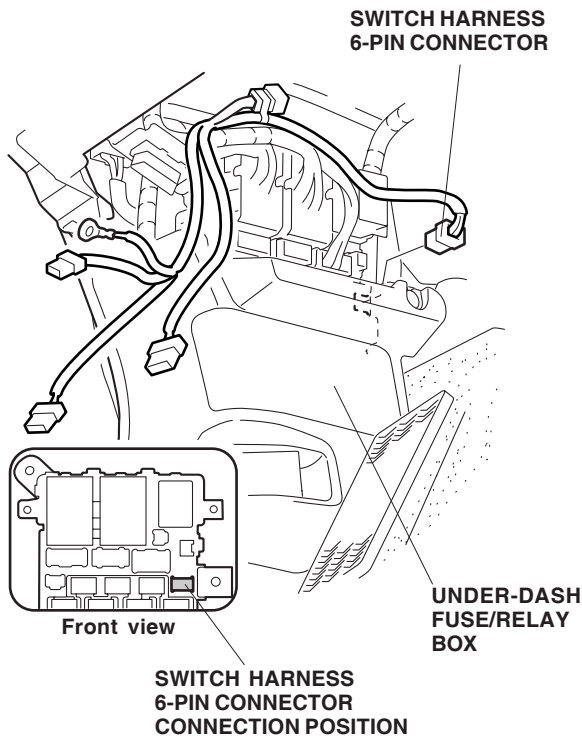

NOTE: If the fuse box 6-pin connector is already being used by another accessory, unplug its 6-pin connector from the under-dash fuse/relay box. Locate the 6-pin connector taped to the switch harness. Remove the dummy connector from the switch harness. Plug the other accessory harness 6-pin into the switch harness, and plug the switch harness 6-pin connector into the under-dash fuse/relay box.

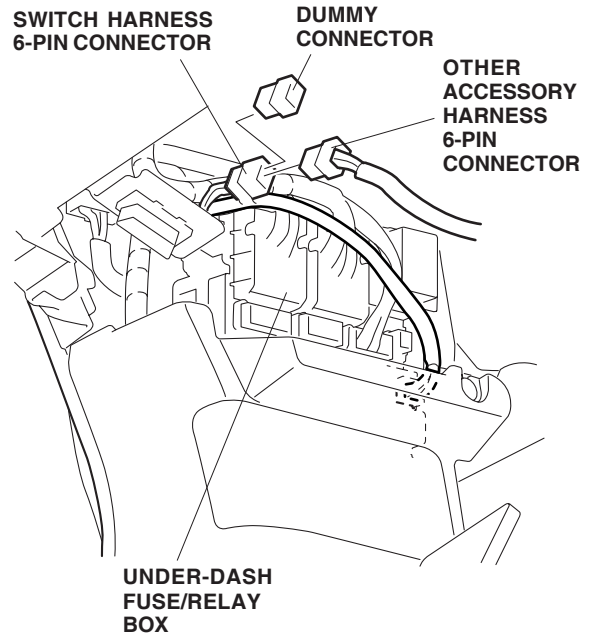

62. Route the switch harness 5-pin connector (blue) to the body panel opening alongside the vehicle harness. Secure the switch harness to the vehicle harness with one wire tie in the area shown.

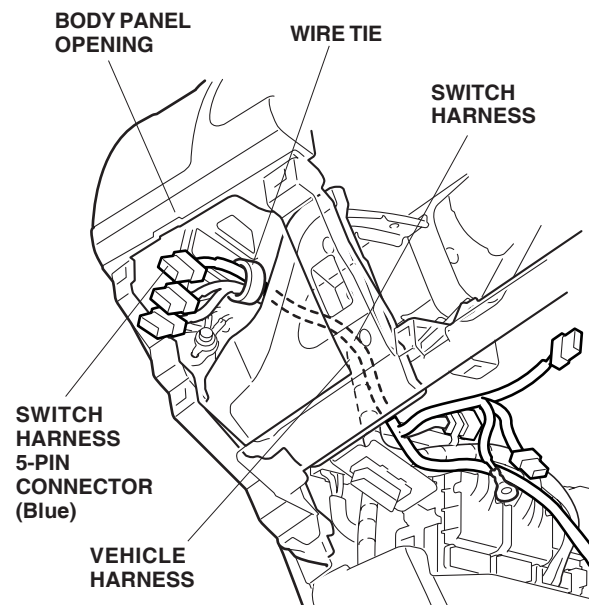

63. Behind the steering hanger pipe, locate the 2-pin connector blue-taped to the vehicle harness. Connect the switch harness 2-pin connector to the vehicle 2-pin connector.

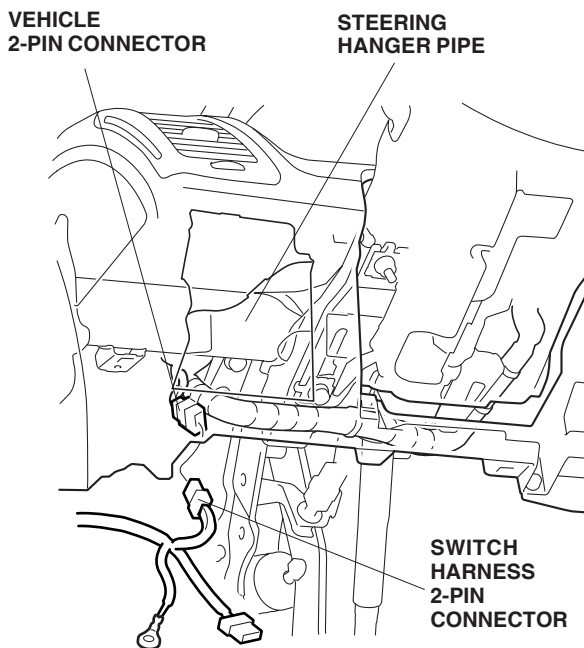

NOTE: If the 2-pin connector is already being used by another accessory, locate the 2-pin connector taped to the other accessory harness. Plug the switch harness 2-pin connector into the other accessory harness.

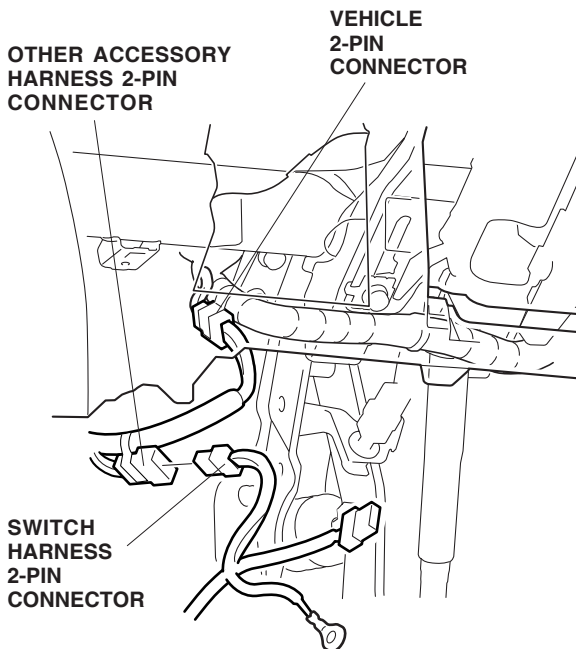

64. Attach the switch harness ground terminal to the steering hanger pipe stay with one of the ground bolts supplied.

Without Cruise Control:

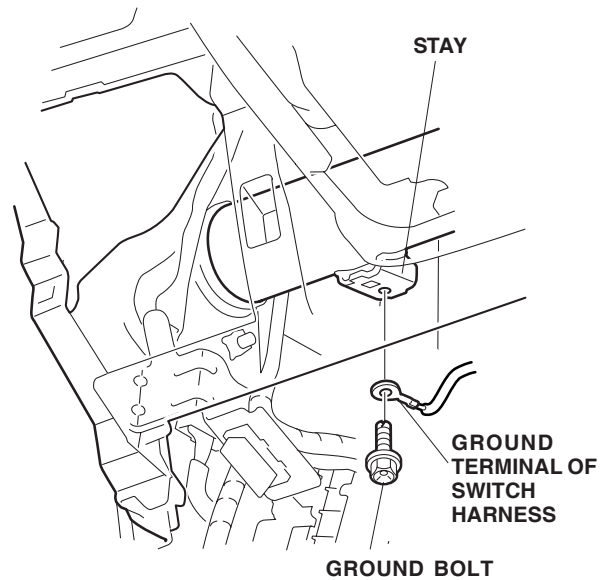

With the Cruise Control:

- Remove and discard the bolt that fastens the control unit, then attach the switch harness ground terminal to the steering hanger pipe with the ground bolt supplied.

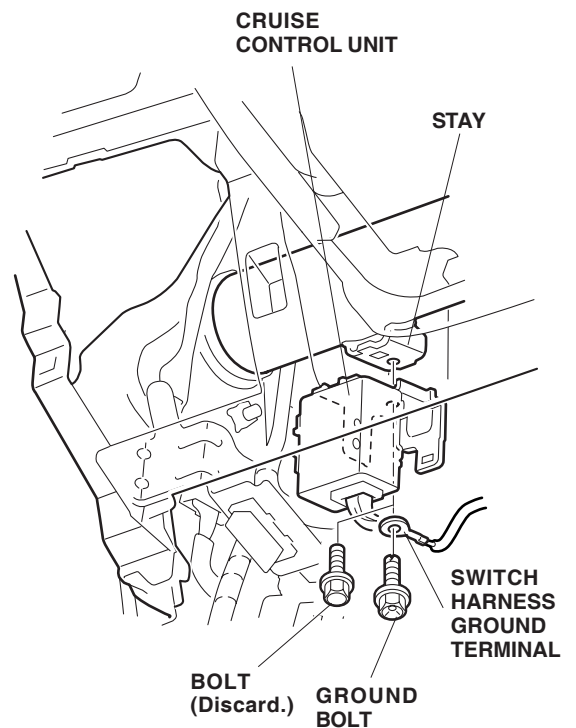

65. On the left of the steering shaft, locate the 3-pin connector black-taped to the vehicle harness, and plug the switch harness 3-pin connector in the 3-pin connector.

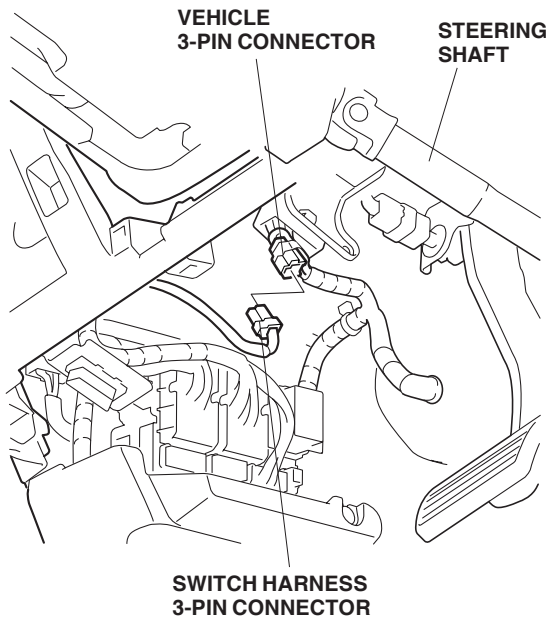

NOTE: If the 3-pin connector is already being used by another accessory, locate the 3-pin connector taped to the other accessory harness. Remove the dummy connector from that other accessory harness. Plug the switch harness 3-pin connector into the other accessory harness.

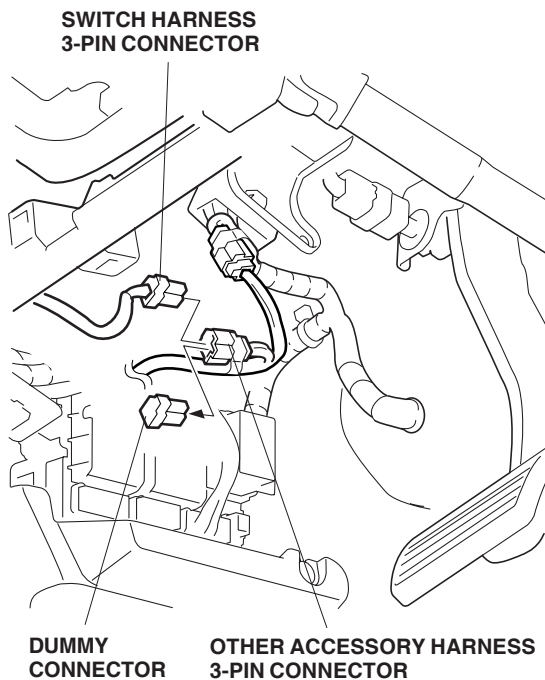

66. Secure the switch harness to the vehicle harness with six wire ties in the areas shown.

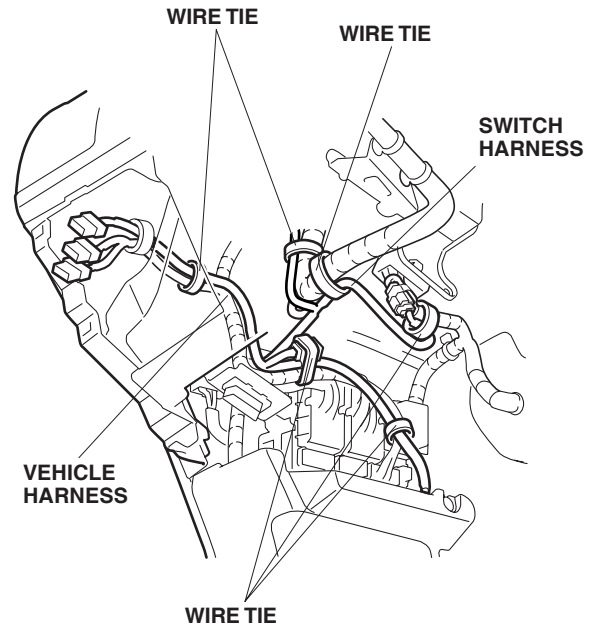

67. Remove the switch cover from the driver's side dashboard lower cover, and install the switch in the driver's dashboard lower cover.

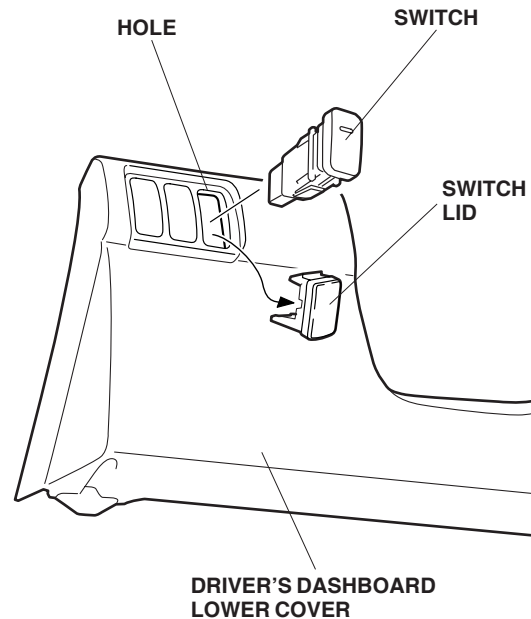

68. If equipped, reinstall the driver's dashboard under cover.

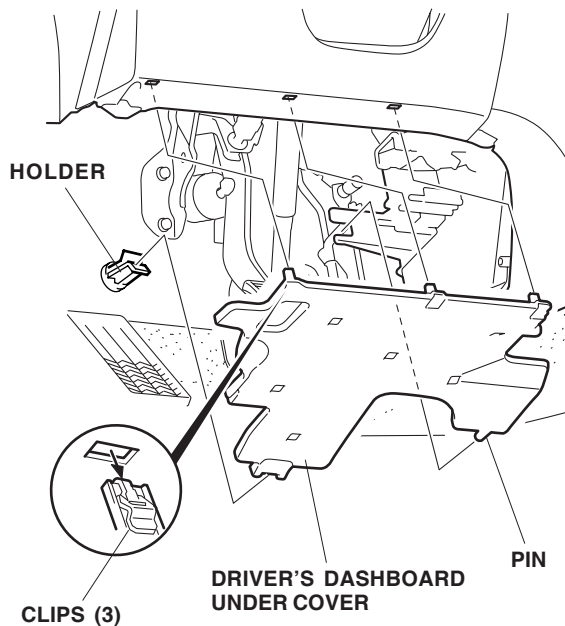

69. Plug the switch harness 5-pin connector (blue) into the switch, then reinstall the dashboard lower cover.

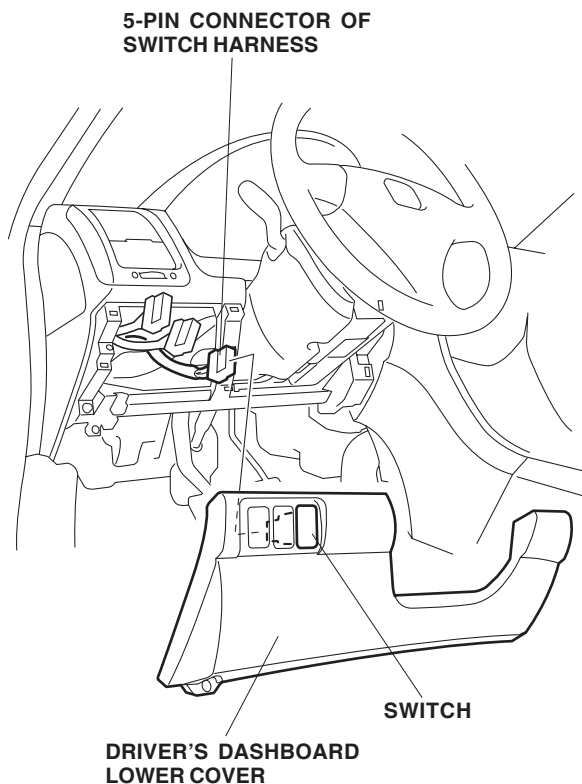

70. Check that all wire harnesses are routed properly and all connectors are plugged in.
71. Reinstall all removed parts. Check that all clips and fasteners are installed securely.
72. Reconnect the negative cable to the battery.

USE AND CARE

How to Operate Fog Lights

- Turn the headlight switch to the "on" position (headlights on low beam).
- Press the fog light switch (indicator is on).

The fog light lenses can cloud when the outside temperature is cold; this is normal and should go away in warm weather.

Fog Light Aiming Adjustment

73. Adjust the fog light:
- Adjust the aiming according to local laws and regulations.
 - To adjust, turn the aiming adjustment screw in or out until the correct aiming is obtained.

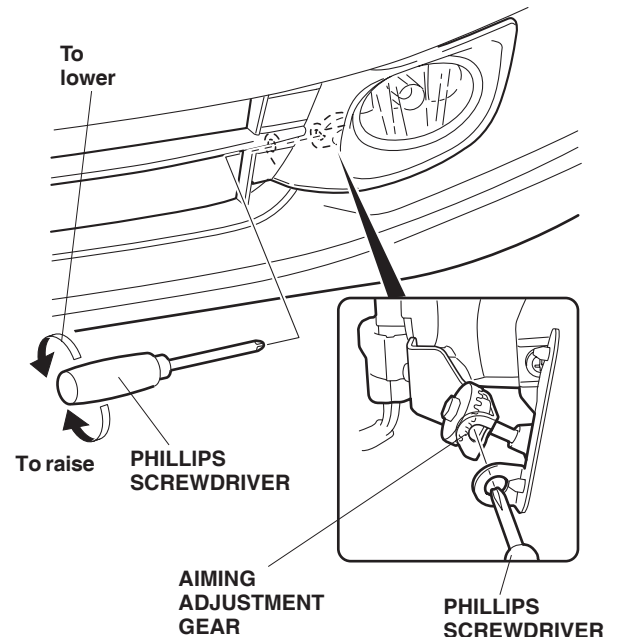

74. Reset the clock, and reset the radio station presets.
75. Do the ECU idle learn procedure.
 - Make sure all electrical items (A/C, audio, rear window defogger, lights, etc.) are off.
 - Reset the PCM with the HDS.
 - Turn the ignition switch ON (II), and wait 2 seconds.
 - Start the engine. Hold the engine speed at 3,000 rpm without load (in Park or neutral) until the radiator fan comes on, or until the engine coolant temperature reaches 194°F (90°C).
 - Let the engine idle about 5 minutes with the throttle fully closed.

NOTE: If the radiator fan comes on, do not include its running time in the 5 minutes.

76. If the IMA battery level gauge (BAT) displays zero segments, start the engine, and hold it between 3,500 rpm and 4,000 rpm (in Park or Neutral) until the IMA battery level displays at least three segments.

NOTE: Whenever the battery is disconnected, the driver's AUTO window function is disabled.

77. Start the engine. Push down on the driver's window switch until the window is fully open.
77. Pull up on the driver's window switch fully to close the window completely, then hold the switch for 2 seconds.
78. Test the driver's AUTO window function.

BULB REPLACEMENT

1. Open the screw covers, remove the two self-tapping screws that fasten the fog light, and pull the fog light out toward you.
2. Unplug the connector from the fog light, and remove the fog light assembly.

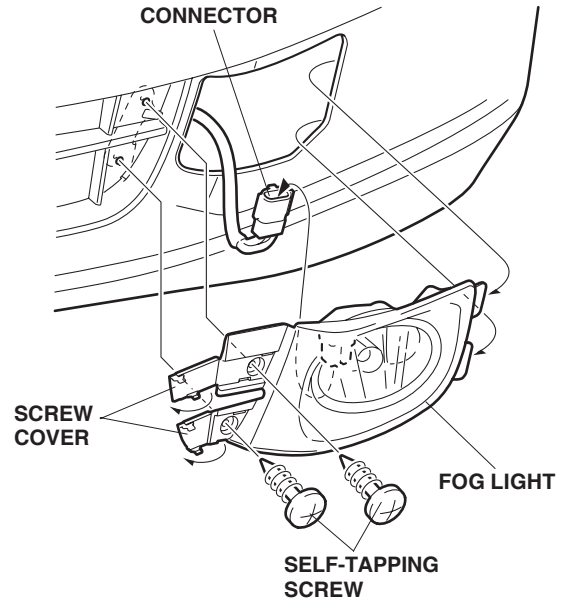

3. Remove the bulb.

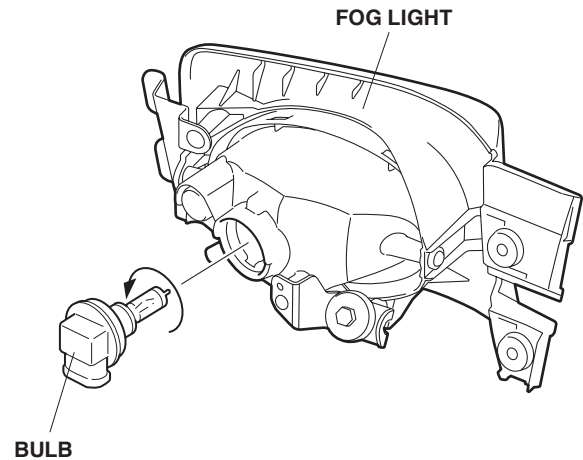

4. Install the new bulb into the socket.

- Use only a genuine Honda halogen light bulb of specified wattage.

Rating: 12V 55W H11 Halogen Light Bulb
P/N 33165-S5A-003

- Do not touch the bulb. Oily or greasy substances on the bulb can shorten its service life due to the heat produced when the bulb is turned on. If the bulb is accidentally touched, wipe it clean with a soft cloth that has been dampened with a denatured alcohol or a mild detergent solution.
- Align the tab on the fog light with the cutout in the bulb when installing the new bulb. If not aligned, the fog light may annoy oncoming drivers.

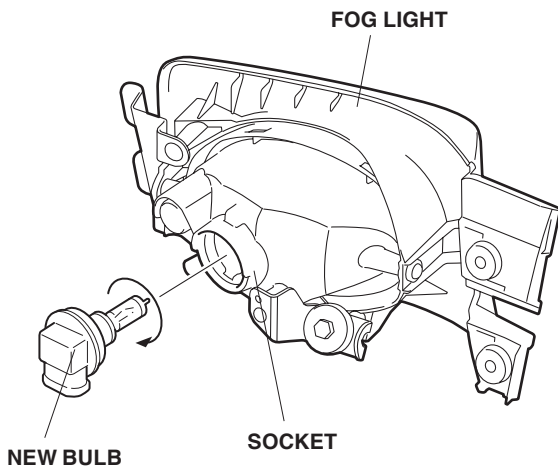

2221050T

5. Reinstall the removed parts in the reverse order of removal.

- Check that the wire harnesses are not pinched.
- Be sure to tighten the self-tapping screw and bolts securely.

6. Check the operation of the fog light; adjust the aiming if necessary.

CIRCUIT DIAGRAM

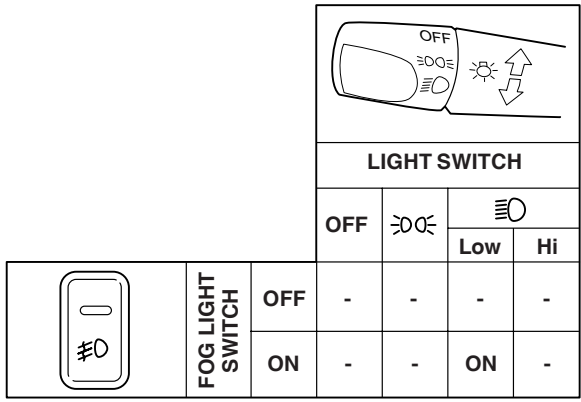
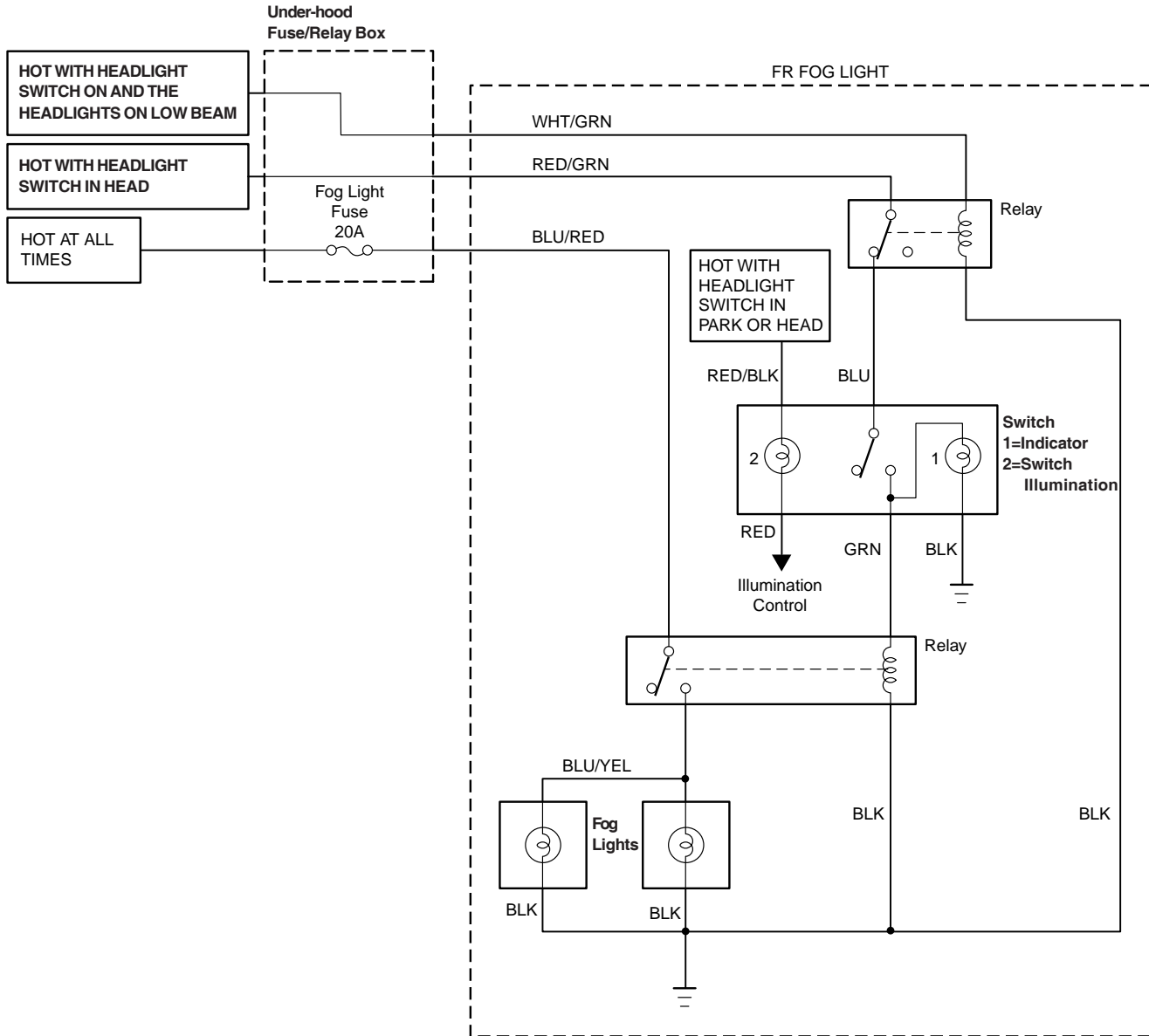

BLK	BLACK	BRN	BROWN
YEL	YELLOW	ORN	ORANGE
BLU	BLUE	PUR	PURPLE
GRN	GREEN	NAT	NATURAL
RED	RED	PNK	PINK
WHT	WHITE	GRY	GRAY
LT BLU	LIGHT BLUE	LT GRN	LIGHT GREEN