



INSTALLATION INSTRUCTIONS

Accessory

BODY SIDE MOLDING

Application

**2006 ACCORD
2-DOOR**

Publications No.

A11 30212

Issue Date

SEP 2005

PARTS LIST

Left door body side molding

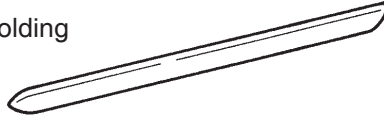

Left quarter panel body side molding



Right door body side molding

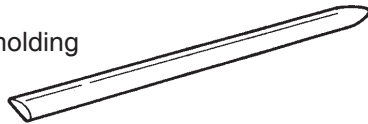

Right quarter panel body side molding



Template

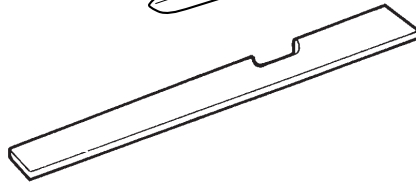

TOOLS AND SUPPLIES REQUIRED

- Isopropyl alcohol
- Shop towel
- Felt-tip pen
- Masking tape
- Tape measure
- Hard rubber roller

INSTALLATION

NOTE:

- Be careful not to damage the body paint finish.
- This body side molding kit should be installed only if the ambient air temperature is 60°F (15°C) or above.
- To allow the adhesive to “cure,” do not wash the vehicle for 24 hours.
- These instructions are for the left side of the car. The same procedure applies to the right side of the car.
- If you're also installing door edge guards (sold separately), install them before you install the body side moldings.

Attaching the Template

1. Position the template on the left door, aligning the template upper edge with the door panel character line and the door handle line. Align the front edge of the template with the door panel edge.

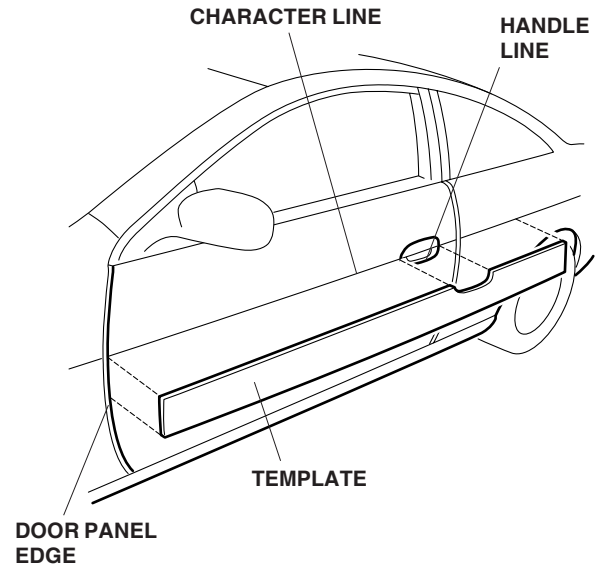

2. Tape the top and sides of the template to the door.

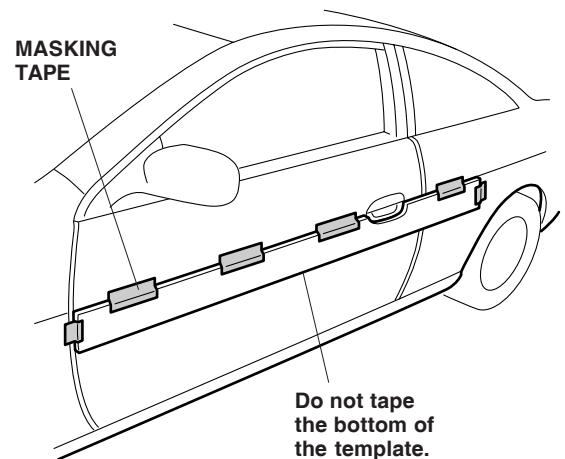

Installing the Door Body Side Molding

- Using isopropyl alcohol on a shop towel, clean the area where the left door body side molding will attach.
- Remove 1½ to 2 inches (40 to 50 mm) of adhesive backing from rear end of the molding, and fold it up diagonally toward the outside.

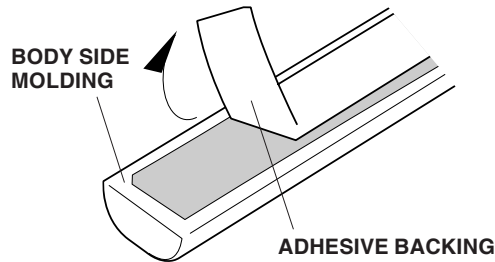

- Position the molding on the door panel, and align the upper edge of the molding with the lower edge of the template. Further adjust the location of the molding so that the clearance between the rear edge of the molding and door panel is ¾ inch (1.5 mm).

With Door Edge Guards

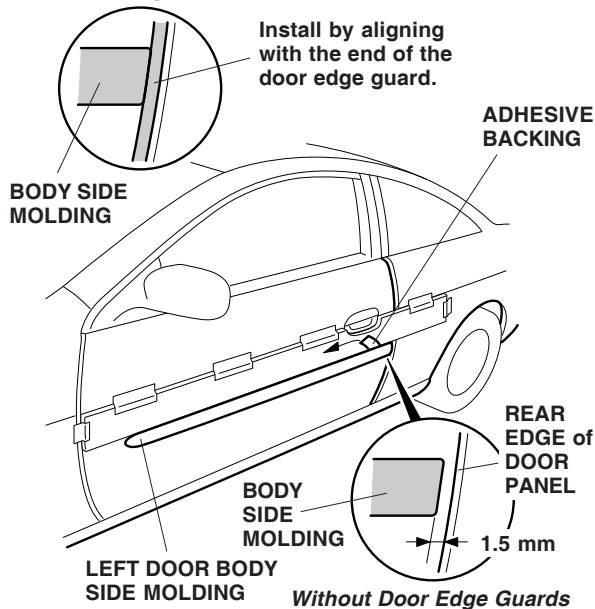

- Attach the rear edge of the molding to the edge of the door. Continue holding the molding in alignment, and carefully pull out about 5¾ inches (150 mm) of tape from under each side; then press the molding into place. Repeat as necessary, 5¾ inches (150 mm) at a time, until the entire length of molding is attached. Do not "stretch" the molding by stroking or smoothing it into place; instead roll or "walk" your hand or fingers against it from back to front.

Installing the Quarter Panel Body Side Molding

- Install the left quarter panel body side molding as described in steps 3 through 6.

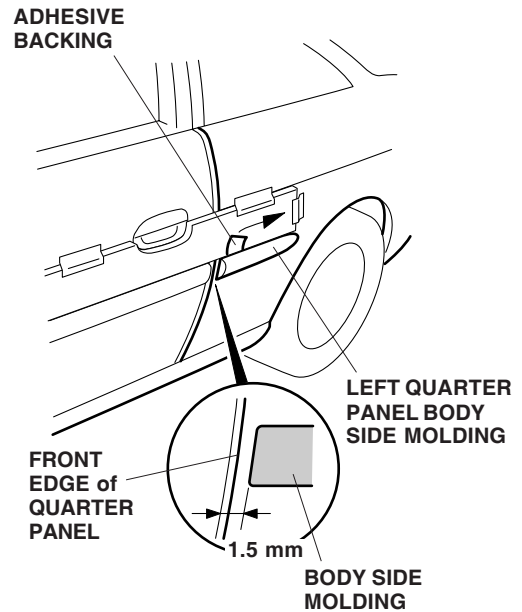

- Remove the template.
- Using a hard rubber roller, apply about 30 lb (15 kg) of pressure along the top edge of each molding, from the one end to the other. Repeat along the bottom edge of each molding.
- Position the template on the right (passenger's) door, and repeat steps 2 through 9 to install the door moldings on the right side of the vehicle.

NOTE: After the body side molding is installed, tell your customer not to wash the vehicle for 24 hours to give the adhesive time to cure.