



# INSTALLATION INSTRUCTIONS

Accessory  
**WOOD-GRAIN  
STEERING WHEEL  
P/N 08U97-S9V-100A**

Application  
**2005 PILOT**

Publications No.  
**All 28083**  
Issue Date  
**SEP 2004**

## PARTS LIST

Wood trim steering wheel

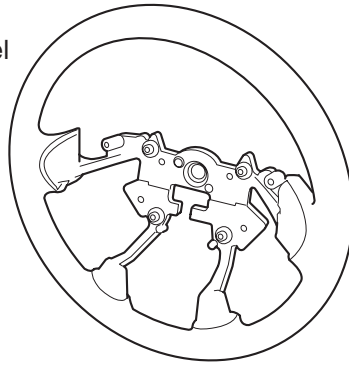

2 Torx bolts



4 Torx bolts



## TOOLS REQUIRED

Phillips screwdriver  
10 mm Combination wrench  
Flat-tip screwdriver  
19 mm T-handle wrench  
Torque wrench  
Steering wheel puller  
T30 and T40 Torx bits

## INSTALLATION

**Customer Information:** The information in this installation instruction is intended for use only by skilled technicians who have the proper tools, equipment, and training to correctly and safely add equipment to your vehicle. These procedures should not be attempted by "do-it-yourselfers."

**NOTE:** After installing the wood-grain steering wheel, you must align the steering wheel spoke angle to the straight ahead position by adjusting the front toe.

1. Make sure you have the anti-theft code for the radio, then write down the radio station presets.
2. Disconnect the negative cable from the battery, and wait for at least 3 minutes before you start to install the wood trim steering wheel.
3. Pry up on the retaining tabs, and remove the access panel from the underside of the driver's side airbag.

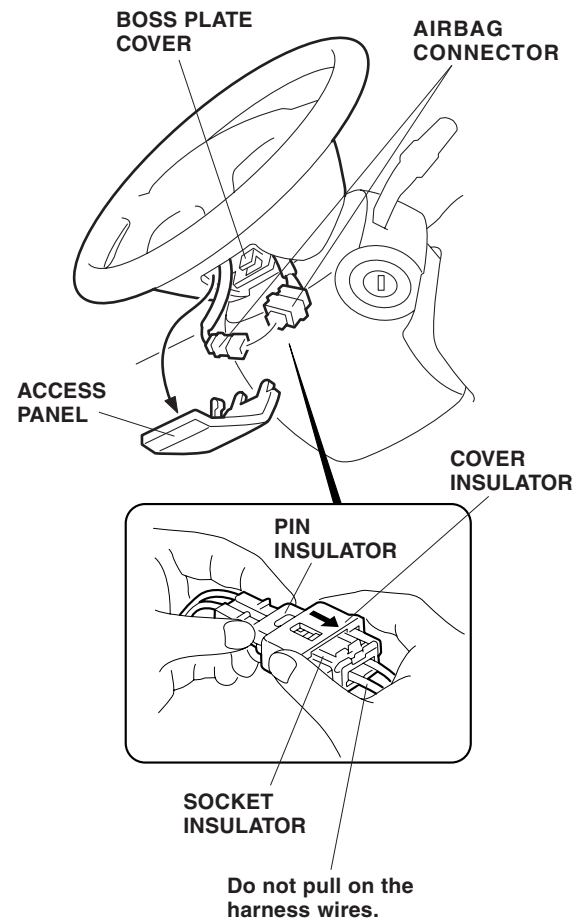

4. Remove the airbag connector from the boss plate cover. Unplug the airbag connectors; while holding the pin insulator, pull out on the cover insulator. Do not pull on the socket insulator.

- Remove and discard the two Torx bolts that secure the airbag, and remove the airbag. Carefully set the airbag in a secure location with the pad facing up. Do not drop or bump the airbag against anything.

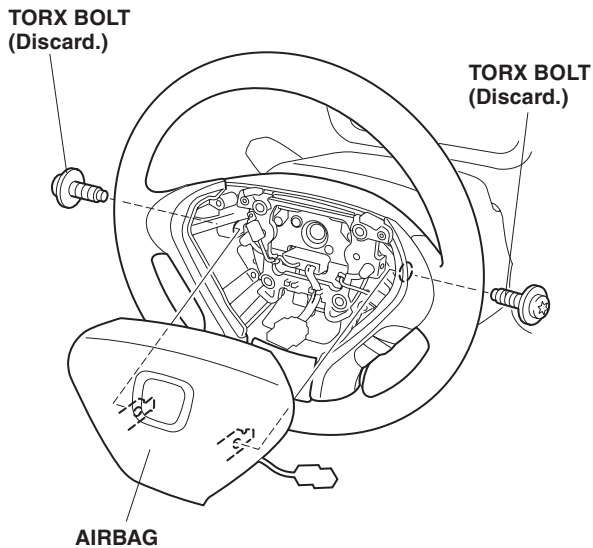

- Turn the steering wheel so the front wheels are in the straight-ahead position.
- If equipped, disconnect the radio remote and cruise switch.

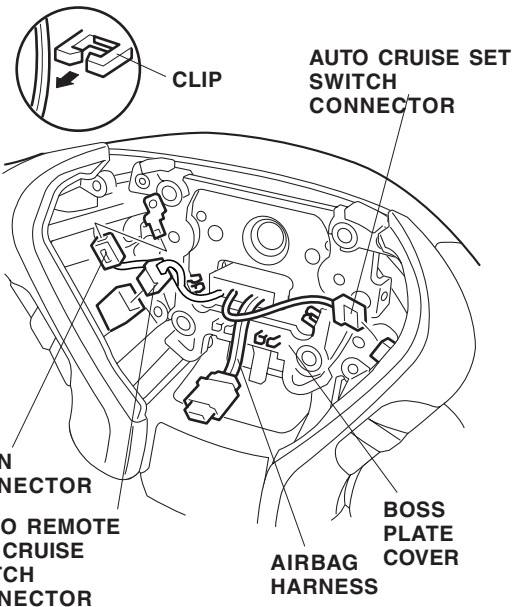

- Disconnect the auto cruise set switch connector and the horn connector.
- Release the airbag harness, the auto cruise set switch harness, and the horn harness from the three clips on the boss plate cover.

- Remove the steering wheel nut, and remove the steering wheel. Be careful not to rotate or turn the steering wheel during removal.

If a steering wheel puller is needed to remove the steering wheel, be careful not to thread the steering wheel puller bolts into the body cover or steering shaft housing farther than 10 mm.

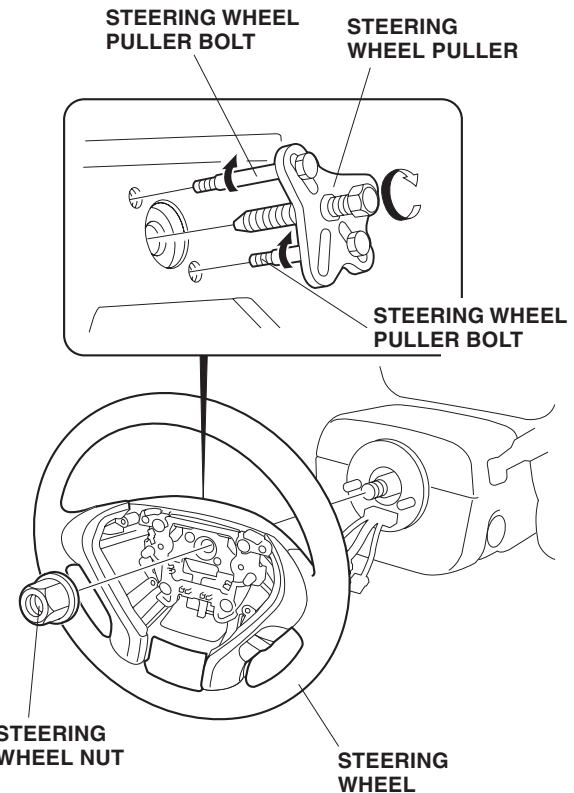

- Remove the four screws that fasten the right and left finishers. Unclip and remove the finishers.

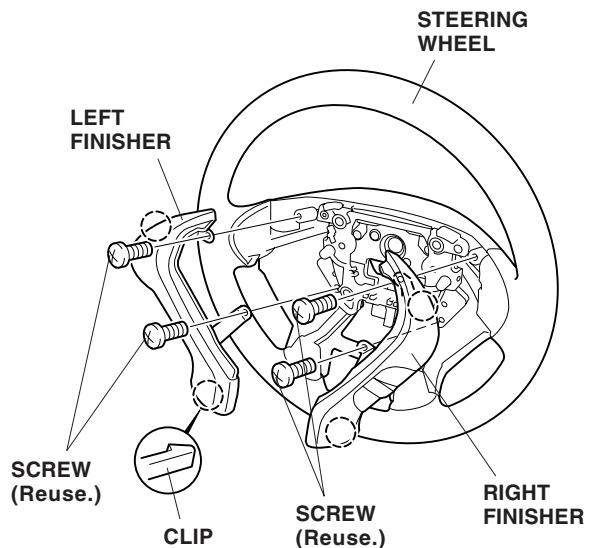

- Remove the boss plate cover (4 Torx bolts with washers). Remove the four springs. Note the location of the springs. Remove and retain the washers from the Torx bolts.

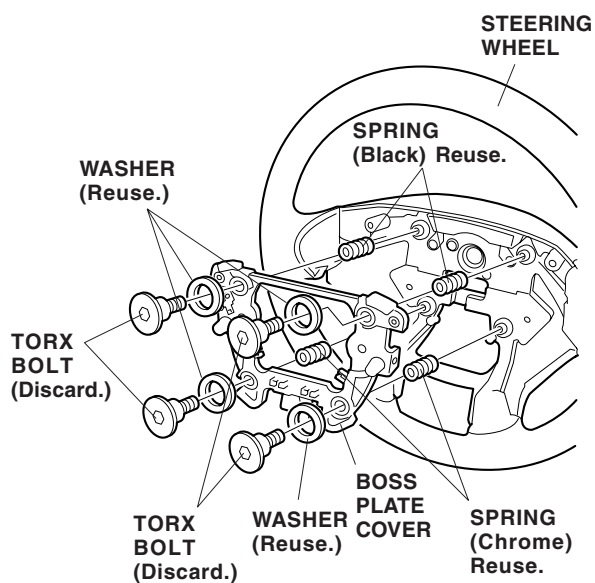

- Remove the steering wheel body cover (four self-tapping screws).

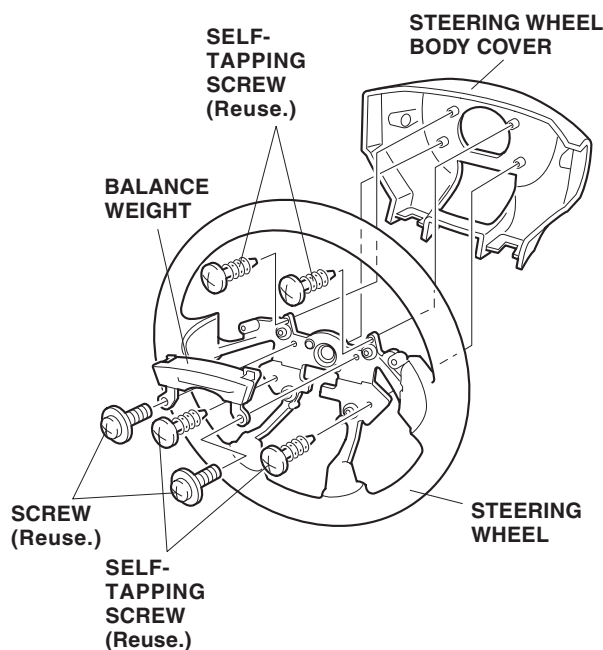

- Remove the steering wheel balance weight (two screws).
- Install the steering wheel balance weight to the wood trim steering wheel with the two screws.

- Install the steering wheel body cover removed in step 13, to the wood-grain steering wheel with the four self-tapping screws (reused).

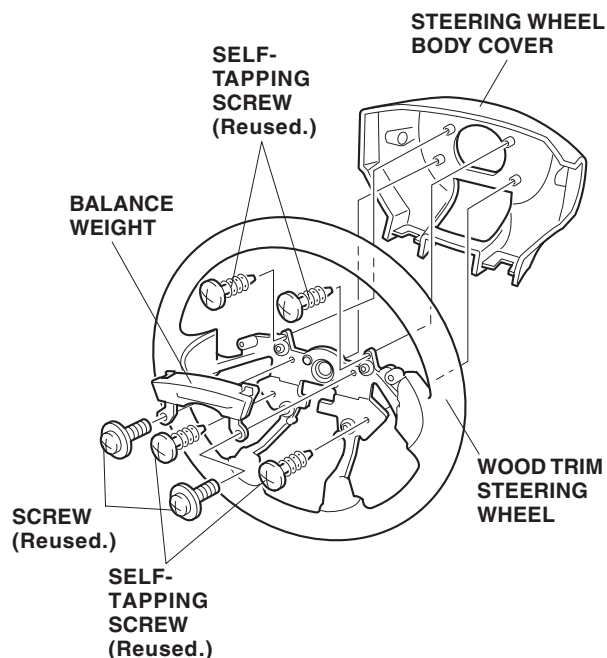

- Get the new Torx bolts, and insert the washers (removed in step 11) over the new Torx bolts. Position the four springs on the wood trim steering wheel, and install the boss plate cover with the four Torx bolts. Torque the bolts to 3 to 9 N·m (2.9 to 3.6 lb-ft).

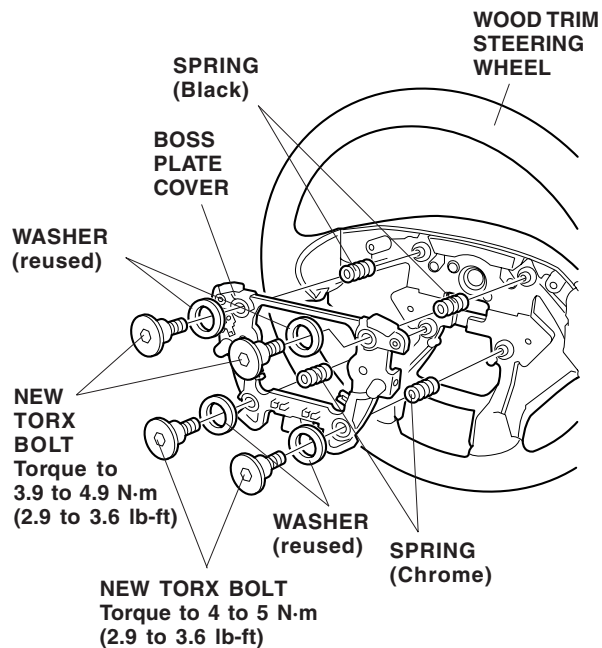

18. Install the right and left finishers to the wood trim steering wheel using the four screws.

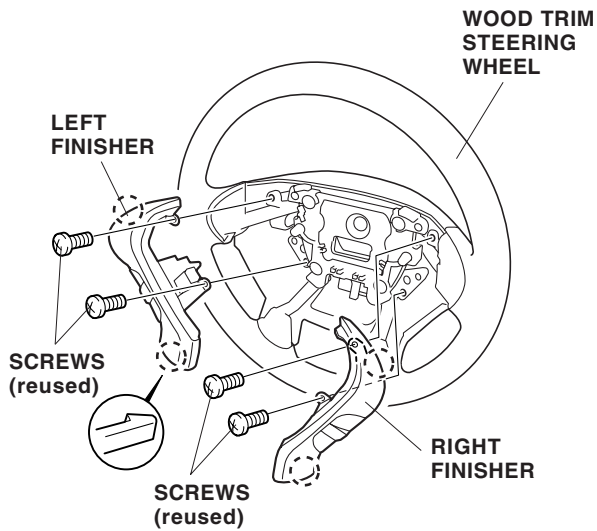

*If the cable reel was moved, continue with step 19; if it was not moved, go to step 20.*

19. Align the cable reel:

- Rotate the cable reel clockwise all the way until it stops.
- Turn the cable reel counterclockwise about two complete turns until the "TOP" arrow on the cable reel points up.

20. Install the wood trim steering wheel on the steering column shaft in the straight-ahead position:

- Route the wire harnesses through the opening in the wood trim steering wheel.
- Align the two tabs of the canceling sleeve with the two cutouts in the steering wheel as shown.
- Check that the wire harnesses are not pinched.

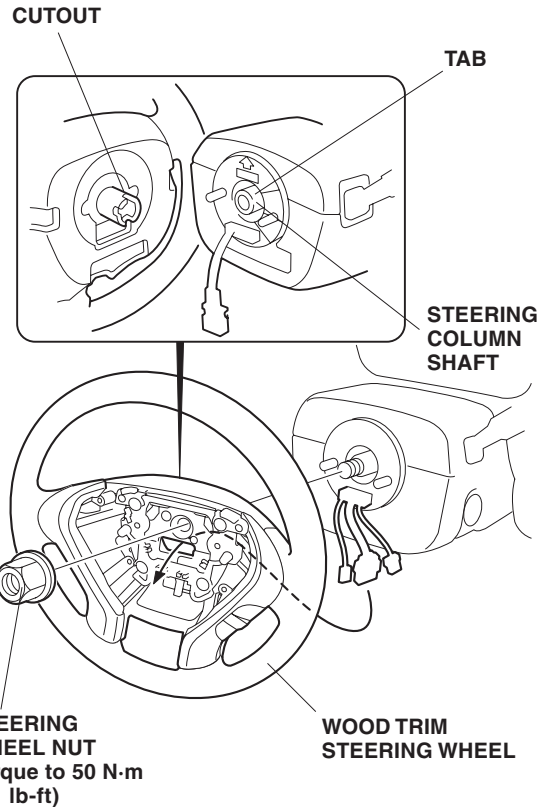

21. Install the steering wheel nut. Torque the steering wheel nut to 50 N·m (36 lb-ft).

22. Plug in the connector for the auto cruise set switch, and connect the horn connector as shown. If equipped, plug in the connector for the radio remote and cruise switch.

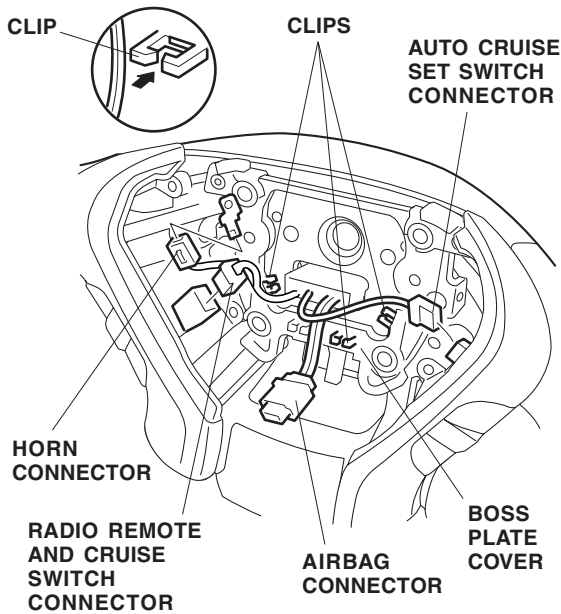

22. Attach the auto cruise set switch wires, the airbag connector wires, and the horn wire to the correct wire clips.
23. Get the airbag, and route the airbag harness down through the steering wheel. Position the airbag on the wood trim steering wheel, and install the two Torx bolts supplied. Torque the Torx bolts to 10 N·m (7 lb-ft).

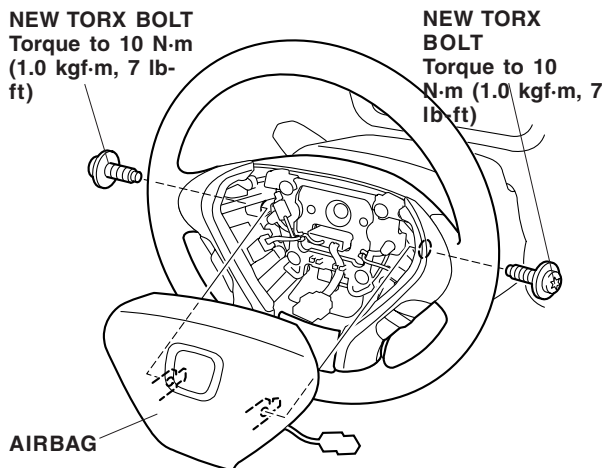

24. Connect the airbag harness connectors:

- Hold on to the socket insulator and push it onto the pin insulator until it contacts the tab on the pin insulator.
- Do not push the socket insulator onto the pin insulator by pushing on the cover insulator.
- Continue pushing the socket insulator in the same direction until the cover insulator rides over the tab on the pin insulator and is locked securely.
- Reattach the airbag harness connector to the boss plate cover.
- Reinstall the access panel.

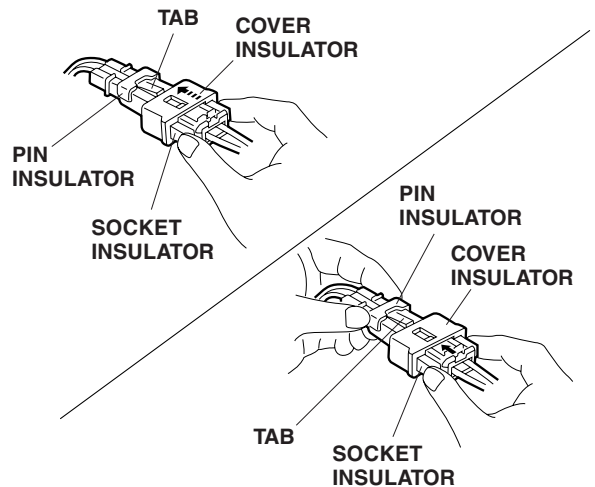
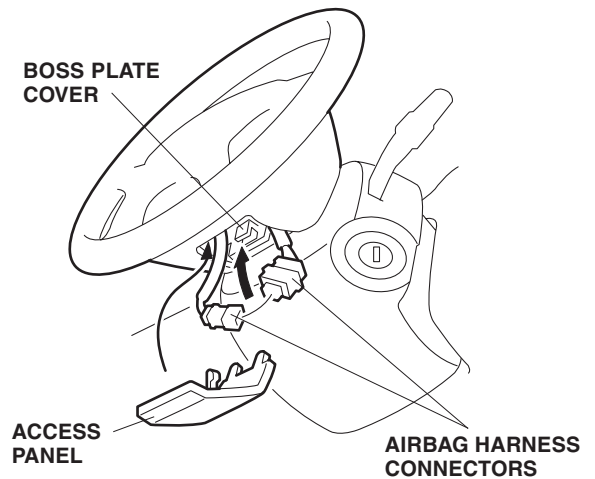

25. Reconnect the negative cable to the battery.
26. Make sure the steering wheel is in the straight-ahead position with the front wheels. If the spoke angle of the steering wheel is not in the straight-ahead position with the front wheels, adjust the front toe as described in the Service Manual.

NOTE: The flat-rate time for installing the steering wheel includes toe adjustment.

27. Verify that the horn works.
28. Turn the ignition key on, and verify that the SRS warning light comes on and stays on for 6 seconds; turn the key off to make sure the SRS warning light goes off.
29. Enter the customer's radio anti-theft code, and reset the radio station presets.
30. Reset the clock.

NOTE: Whenever the battery is disconnected, the driver's AUTO window function is disabled.

31. Start the engine. Push down on the driver's window switch until the window is fully open.
32. Pull up on the driver's window switch to close the window completely, then hold the switch for 2 seconds or more.
33. Test the AUTO window function.
34. Do the PCM idle learn procedure.
  - Make sure all electrical items are turned off.
  - Start the engine. Hold the engine speed at 3,000 rpm with no load (in Park or Neutral) until the radiator fan comes on.
  - Let the engine idle for about 5 minutes with the throttle fully closed and with all electrical items off.

NOTE: If the radiator fan comes on during this step, the time it operates must not be included in the 5 minutes.