



INSTALLATION INSTRUCTIONS

Accessory
SIDE STEPS
 P/N 08L33-S9V-100A (BLACK)
 P/N 08L33-S9V-100B (CHROME)

Application
2005 PILOT

Publications No.
All 28074
 Issue Date
SEP 2004

PARTS LIST

Left side step

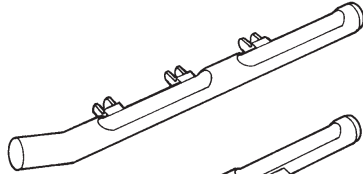

Right side step

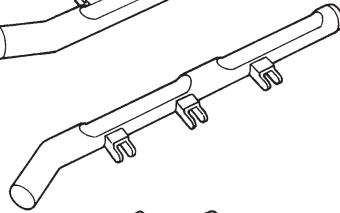

6 "A" brackets

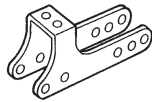

6 "B" brackets



24 Long flange bolts



48 Short flange bolts



48 Flange nuts



TOOLS AND SUPPLIES REQUIRED

Ratchet

Clip remover

13 mm Socket

13 mm Combination wrench

Extension

Blanket

Torque wrench

INSTALLATION

Customer Information: The information in this installation instruction is intended for use only by skilled technicians who have the proper tools, equipment, and training to correctly and safely add equipment to your vehicle. These procedures should not be attempted by "do-it-yourselfers."

NOTE:

- Thoroughly clean the bottom of the body from the rear of the front wheels, up to the front of the rear wheels.
- Be careful not to damage the body paint finish. To prevent damage, place a blanket under the side step during the installation.
- These instructions show the left side side step being installed; the same procedure applies to installing the right side step.

1. Assemble two front bracket assemblies using brackets "A" and "B" along with four short flange bolts, and four flange nuts. Be sure to use the outboard holes in bracket "B." Don't tighten these nuts yet.

Front Bracket Assembly

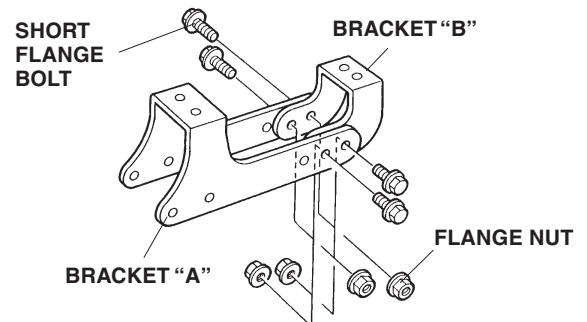

2. Assemble four center and rear bracket assemblies using brackets "A" and "B" along with four short flange bolts, and four flange nuts. Be sure to use the inboard holes in bracket "B." Don't tighten these nuts yet.

Center and Rear Bracket Assembly

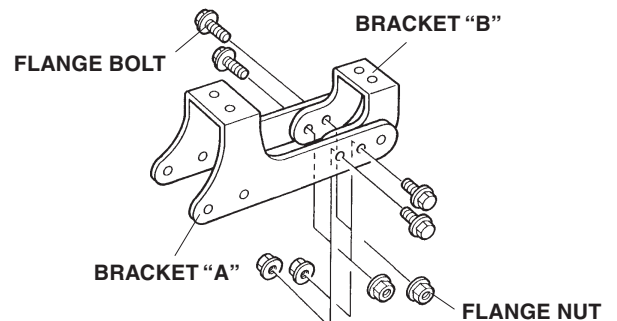

- Remove the six clips from the bottom of the body. Push in on the center of each clip, and remove it using a clip remover tool. The clips will not be reused.

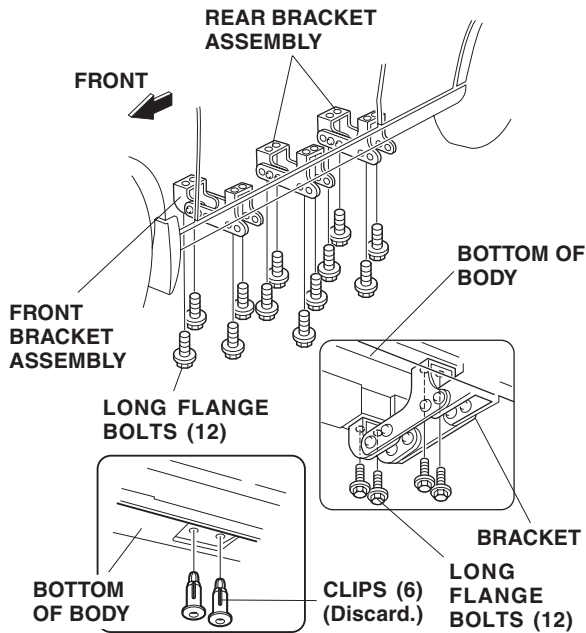

- Install the one front bracket assembly and the two rear and center bracket assemblies to the body using 12 long flange bolts. Thread the long flange bolts in about 3 or 4 threads.
- Position the side step to the brackets using 12 short flange bolts and twelve flange nuts. Thread the short flange bolts in about three or four threads.

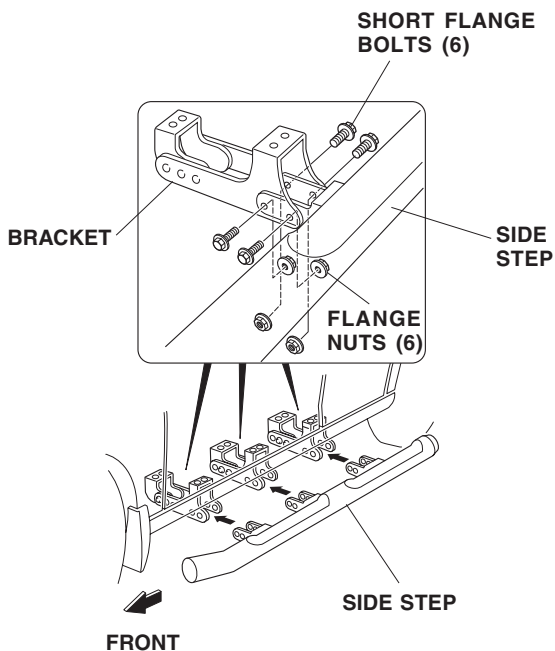

- Adjust the location of the left side step so that there is even clearance between the side step and the body, then tighten the long flange bolts installed in step 4. Torque the long flange bolts to 27 N·m (20 lb-ft).

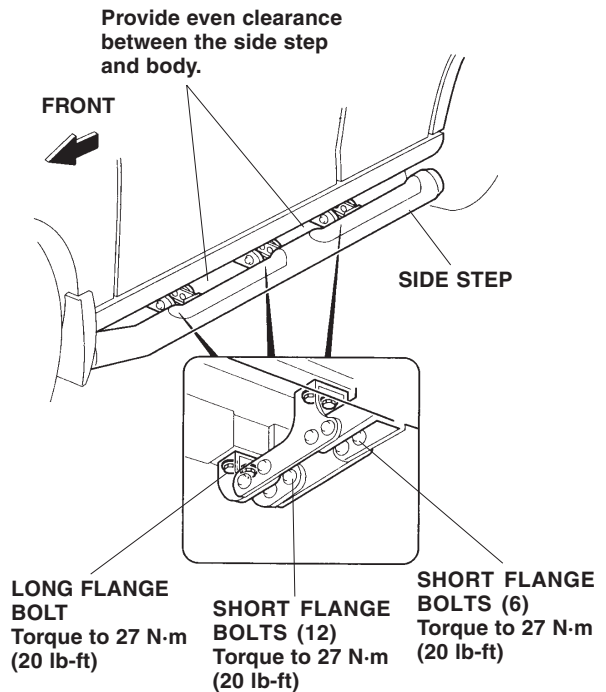

- Torque the 12 short flange bolts installed in step 2 to 27 N·m (20 lb-ft).
- Torque the six short flange bolts installed in steps 1 and 2 to 27 N·m (20 lb-ft).
- Repeat steps 3 through 8 to install the side step on the right side of the vehicle.