



INSTALLATION INSTRUCTIONS

Accessory

**AIR DEFLECTOR
P/N 08P47-S9V-102**

Application

2005 PILOT

Publications No.

All 28038-30102

Issue Date

JULY 2005

PARTS LIST

Air deflector

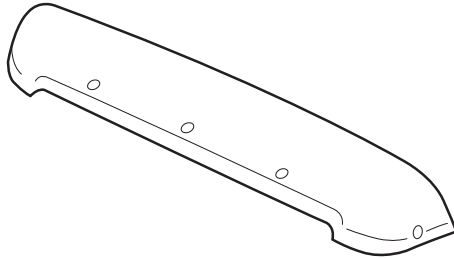

Center bracket

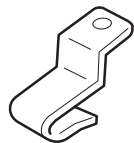

2 Front brackets



2 Side brackets



2 Plastic grommets



2 Screws, 5 x 15 mm



2 Screws, 6 x 1.0 mm



5 Protective tapes

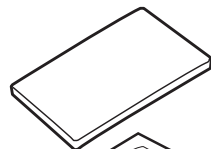

Alcohol pad

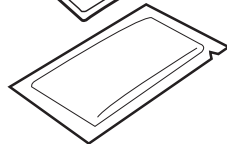

3 Clips



2 Collars



2 Rivnuts, 6 x 1.0 mm



Hood label

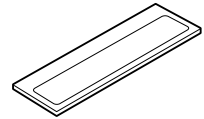

2 Screws, 6 x 14 mm



2 Nylon washers



TOOLS AND SUPPLIES REQUIRED

#2 Phillips screwdriver

Tape measure

Felt-tip pen

Shop towel

Masking tape

Drill

3 mm, 6 mm, and 10 mm Drill bits

File

Touch-up paint

Eye protection (face shield, safety goggles, etc.)

Rivnut tool, 6 x 1.0 mm (Available through the Honda

Tool and Equipment program (888) 424-6857)

INSTALLATION

Customer Information: The information in this installation instruction is intended for use only by skilled technicians who have the proper tools, equipment, and training to correctly and safely add equipment to your vehicle. These procedures should not be attempted by "do-it-yourselfers."

NOTE:

- Be careful not to damage the body finish when you install the air deflector.
- This air deflector should be installed only when the ambient air temperature is 60°F (15°C) or above.

1. Open the hood. Locate the two outer square holes on the inside of the hood. Push one plastic grommet into each outer square hole.

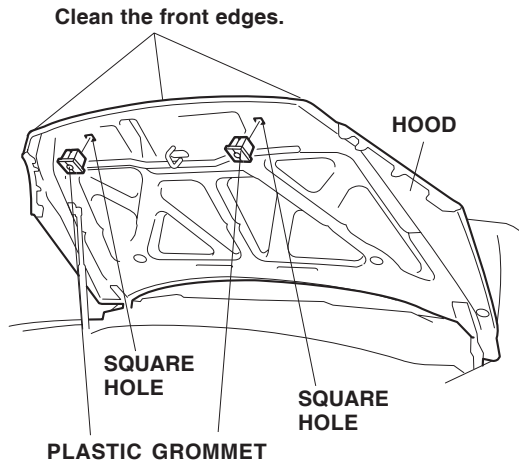

2. Clean the front edge of the hood with the alcohol pad included in the kit.
3. Locate the dimpled area at the inside edge of the hood. While wearing eye protection, drill a 10 mm hole through each of the two dimpled areas.
 - To prevent drilling through the inner panel, wrap masking tape around the drill bit at a point 10 mm away from the tip.
 - First drill with a 3 mm drill bit, then with a 6 mm drill bit, and finish with a 10 mm drill bit.
 - After drilling, remove any burrs from the edges of the 10 mm holes with a file and apply touch-up paint.

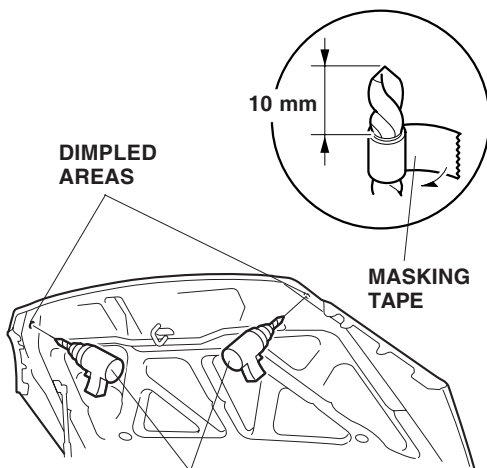

DRILL
(First drill with a 3 mm drill bit, then with a 6 mm drill bit, and finish with a 10 mm drill bit.)

4. Install the two rivnuts into the two holes in the hood using the following procedure:

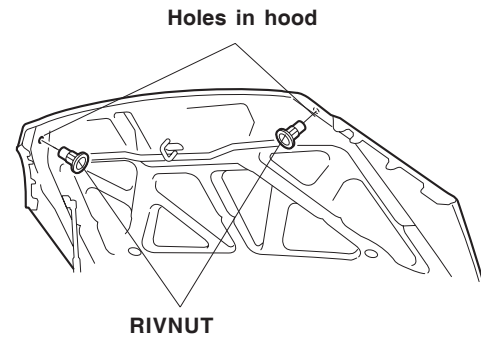

- Thread the rivnut onto the mandrel of the tool as shown.

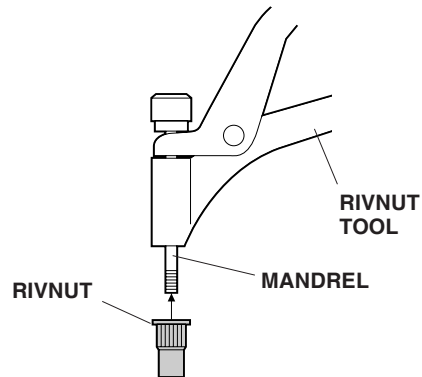

- Insert the rivnut into the hole in the body panel.

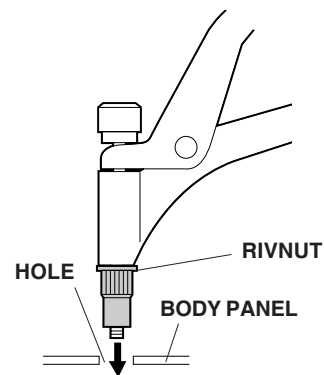

- Squeeze the handle firmly until the rivnut is compressed to form a flange-like stopper under the body panel.

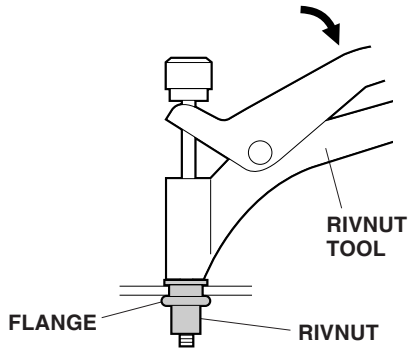

- Release the handle, turn the mandrel, and take the tool off the rivnut.

5. Temporarily slide the front brackets over the lip of the hood, and align the hole in the bracket with the hole in the plastic grommets. Install the 5 x 15 mm screw. Repeat on the other side.

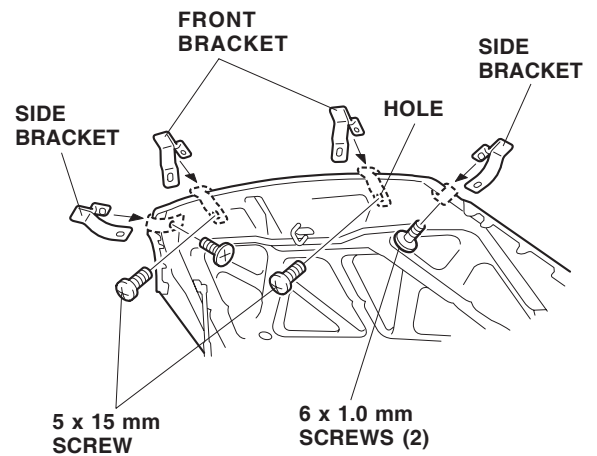

6. Temporarily slide the side brackets over the lip of the hood, and align the hole in the bracket with the rivnut. Install the 6 x 1.0 mm screw. Repeat on the other side.
7. Attach a piece of masking tape to the hood under each front bracket and side bracket.

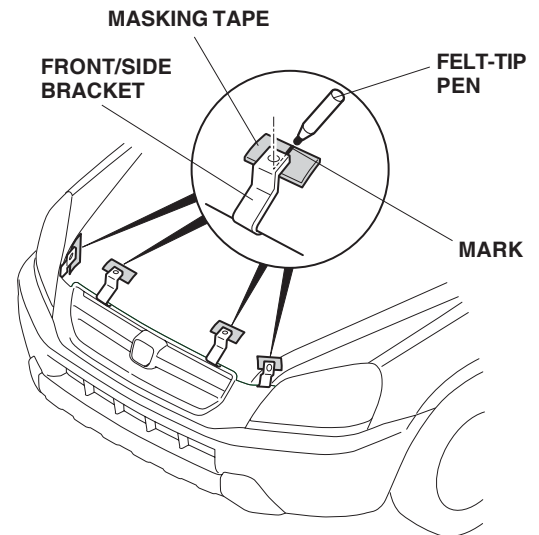

8. Using a felt-tip pen, mark the masking tape where each front bracket and side bracket will rest, then remove the front brackets and side brackets.

- Attach five protective tapes around the front of the hood at each marked location.

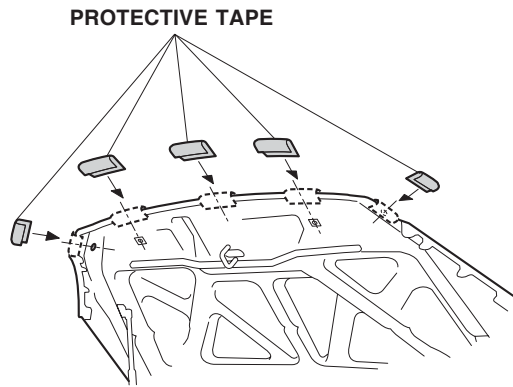

- Attach the remaining protective tape around the center of the hood.
- Reinstall the two side brackets over the hood around the protective tapes and hood gasket, and install the 6 x 1.0 mm screws.

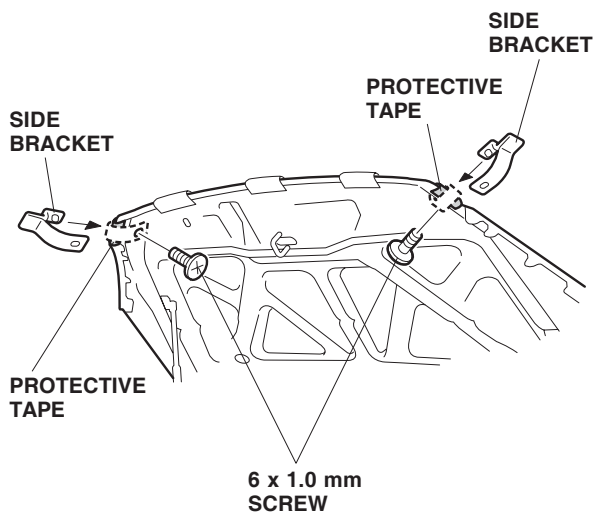
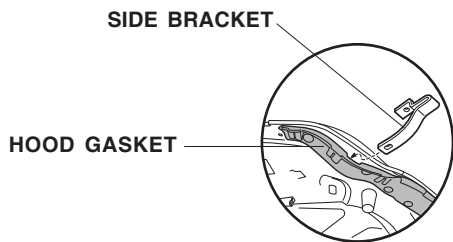

- Attach the two front brackets and the center bracket to the air deflector using the three clips.

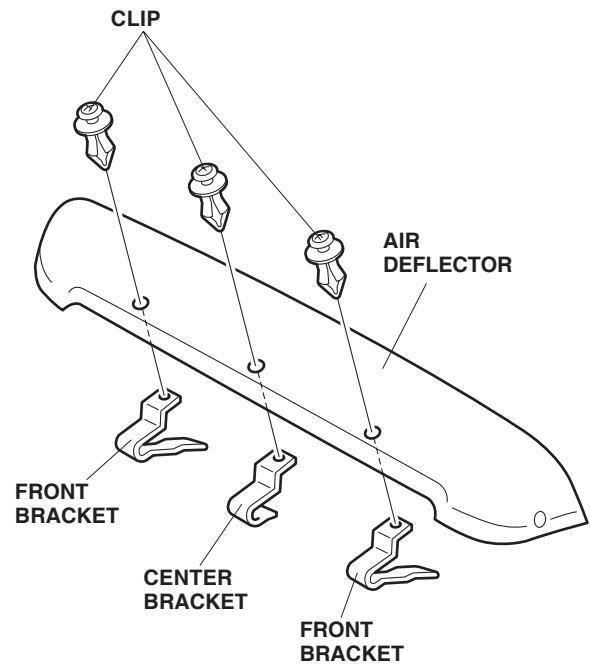

- Close the hood, and position the air deflector on the hood by sliding the two front brackets and the center bracket over the three protective tapes; align the holes in the air deflector over the two brackets. Install the two 6 x 14 mm screws, the two nylon washers, and two collars, then tighten the screws securely.

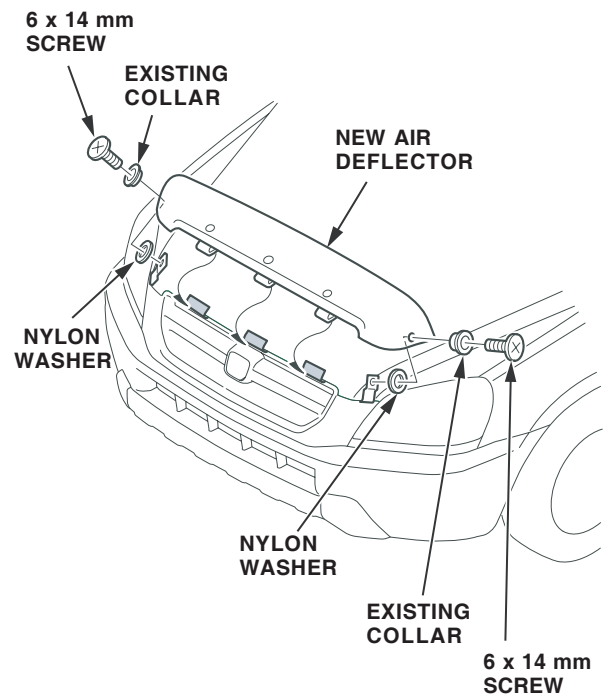

14. Open the hood. Install the two 5 x 15 mm screws.

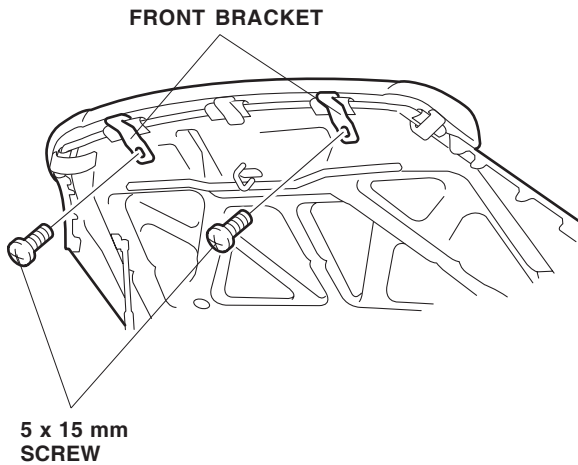

15. Using isopropyl alcohol on a shop towel, thoroughly clean the area where the hood label will attach.
16. Remove the adhesive backing from the hood label and attach it to the engine hood in the area shown. Hold the label firmly against the hood with the palm of your hand for 2 seconds.

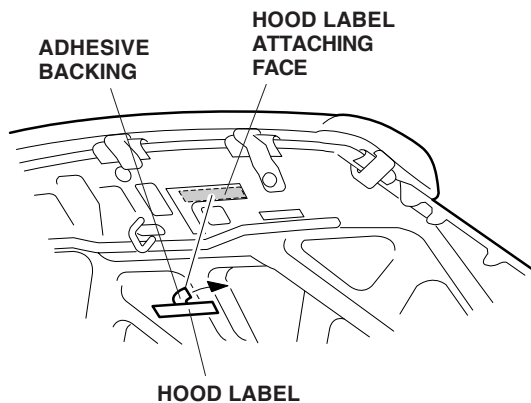

NOTE: After the air deflector is installed, tell your customer not to wash the vehicle for 24 hours to allow the adhesive to cure.