



# INSTALLATION INSTRUCTIONS

Accessory

ENGINE BLOCK HEATER  
P/N 08T44-S5B-100

Application

2005 CIVIC  
2- AND 4-DOOR

Publications No.

All 27861

Issue Date

AUG 2004

## PARTS LIST

Engine block heater

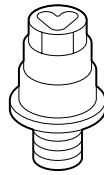

Aluminum washer



Heater harness

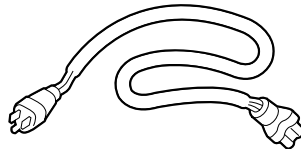

Protective cap

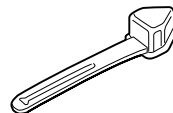

12 Short wire ties

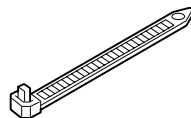

## TOOLS AND SUPPLIES REQUIRED

Ratchet

10 mm, 19 mm, and 24 mm Sockets

Torque wrench

Wrench (1/2 inch)

Diagonal cutters

Drain pan

Blanket

Coolant (Honda All Season Antifreeze/Coolant Type 2)

### NOTE:

- Always use Honda All Season Antifreeze/Coolant Type 2. Using a non-Honda coolant can result in corrosion, causing the cooling system to malfunction or fail.
- To avoid burning out the element, do not operate the engine block heater before it is installed in the vehicle or before you add coolant.

## INSTALLATION

**Customer Information:** The information in this installation instruction is intended for use only by skilled technicians who have the proper tools, equipment, and training to correctly and safely add equipment to your vehicle. These procedures should not be attempted by "do-it-yourselfers."

1. Allow the engine and all cooling system components to cool down.
2. Remove the five bolts securing the resonator, then disconnect the intake air duct and the air cleaner duct. Unclip the wire harness, and remove the resonator.

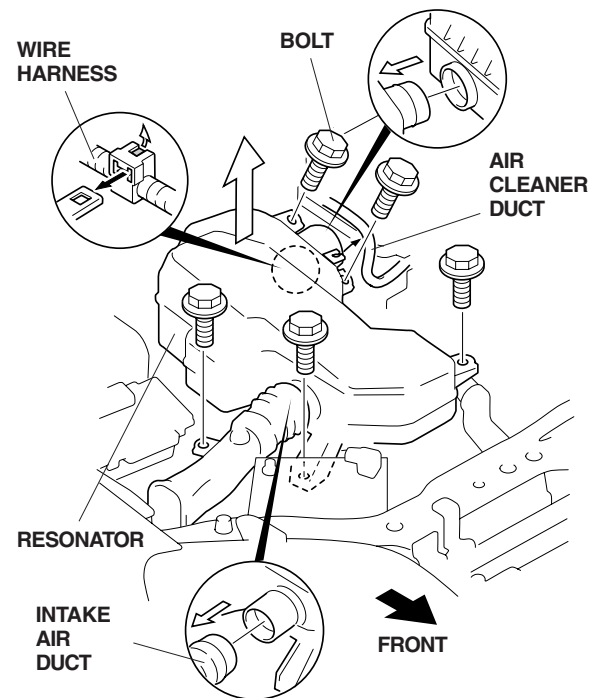

- Route the heater harness connector down below the air cleaner.

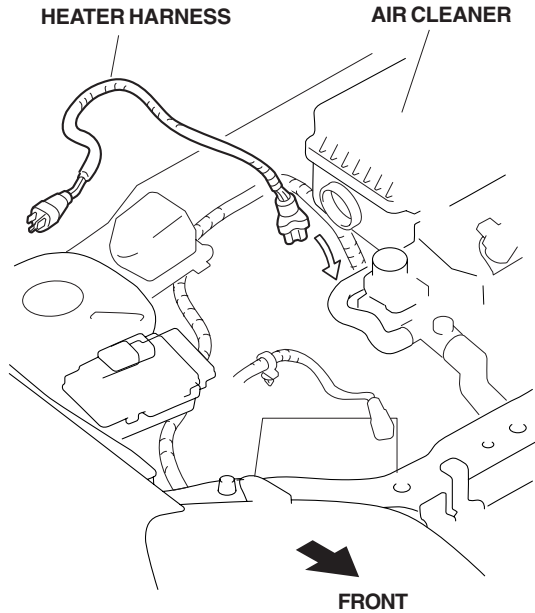

- Remove the front bumper (ten clips and four self-tapping screws). Set the bumper on a blanket to prevent damage.

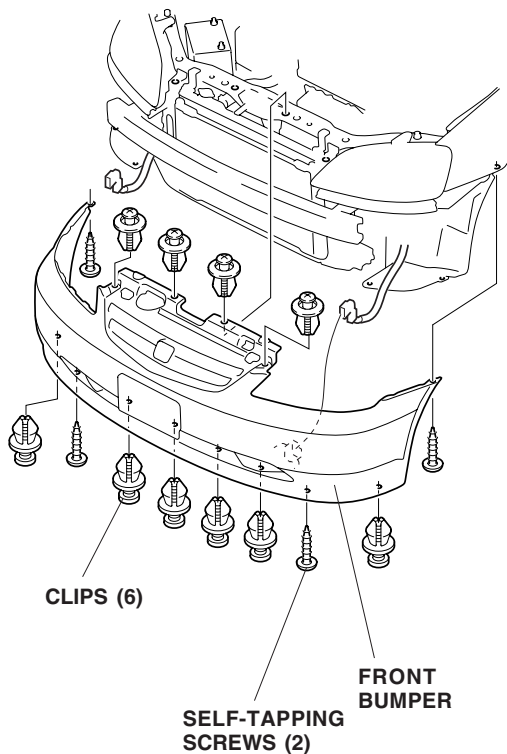

- Place a clean drain pan under the radiator drain plug, then remove the drain plug from the bottom of the radiator to drain the coolant. Remove the radiator cap to increase the flow.

**NOTICE** Radiator coolant will damage paint. Quickly rinse any spilled coolant from painted surfaces.

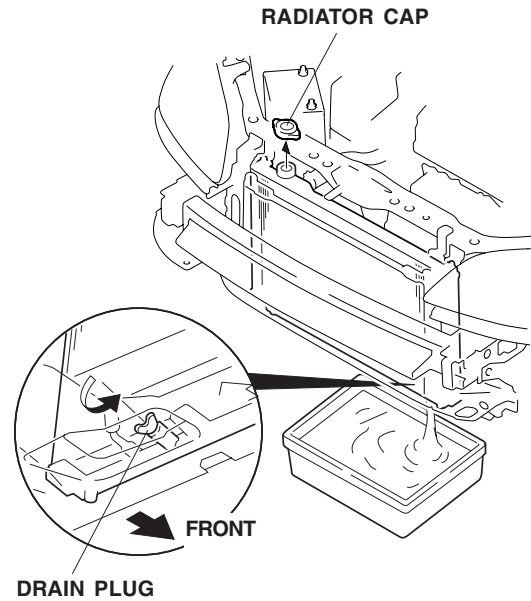

- On the rear of the engine, locate and remove the engine block drain bolt and washer. Coolant remaining in the engine jackets flows out of the bolt hole when the bolt is removed. (Retain the drain bolt in case the engine block heater is removed.)

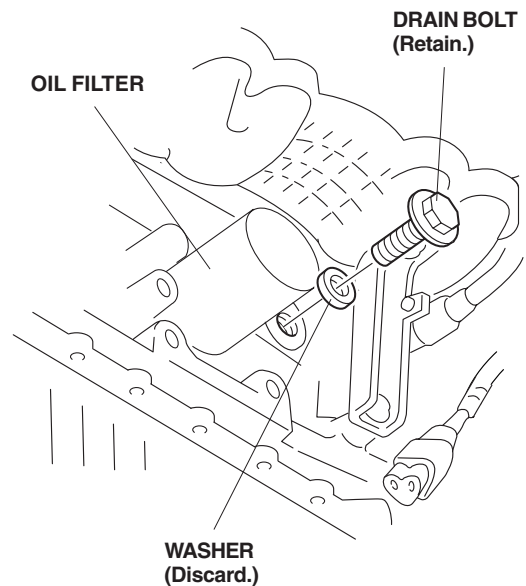

- Install the new aluminum washer and the engine block heater into the bolt hole using a 24 mm socket and a torque wrench. Torque the engine block heater to 60 N·m (44 lb-ft).

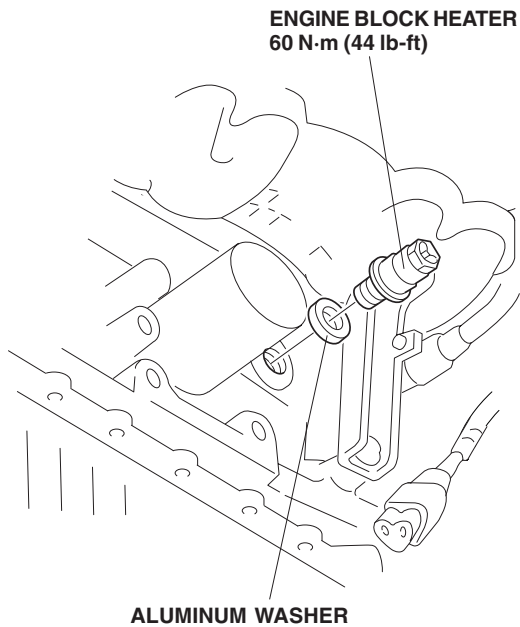

- Plug the connector of the heater harness into the engine block heater.

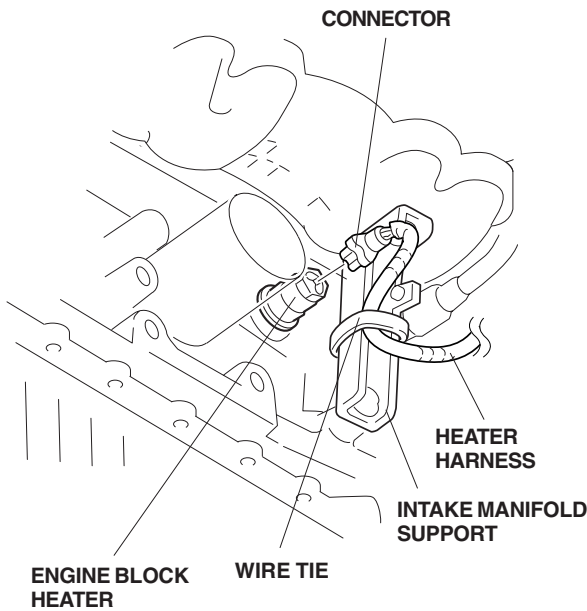

- Secure the heater harness to the intake manifold using one wire tie in the area shown.

- Route the heater harness along the vehicle harness, and secure it to the vehicle harness with five wire ties.

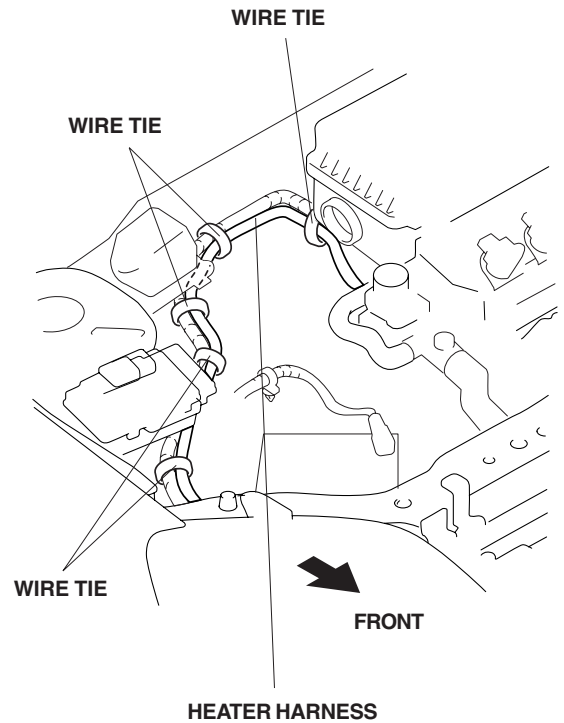

- Route the heater harness connector out through the opening under the right headlight, and secure it to the holes in the bumper upper beam and lower cross member with three wire ties.

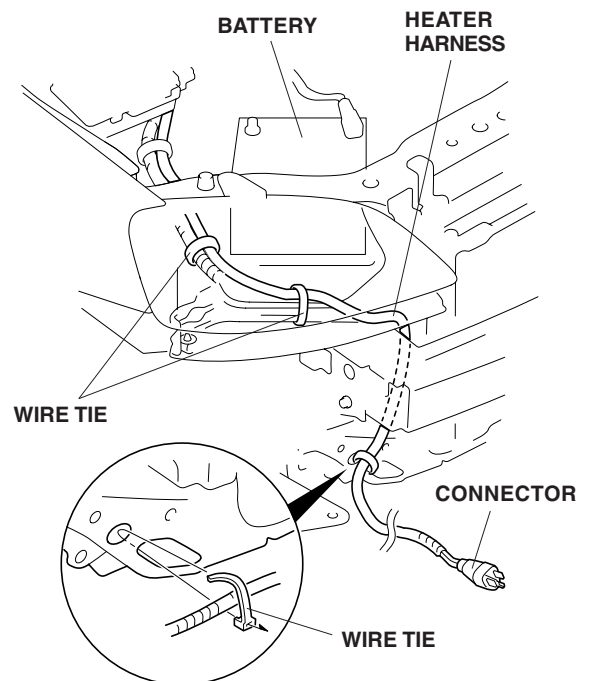

12. Route the heater harness through the front bumper grille, then reinstall the front bumper.

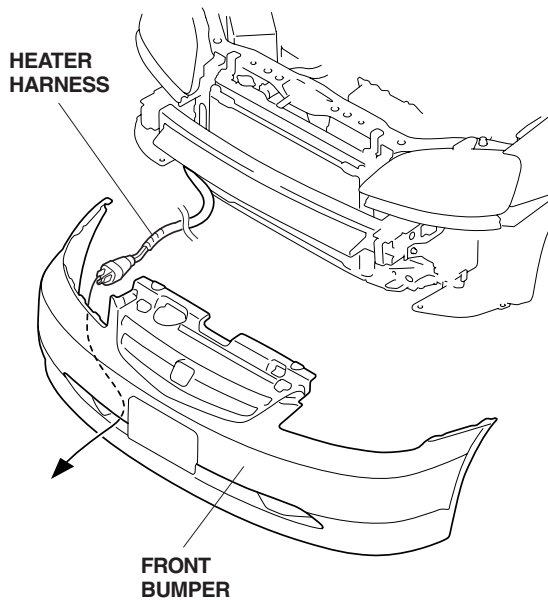

13. Continue routing the heater harness to the left alongside the front bumper grille, and secure it to the bumper grille with four wire ties in the areas shown.

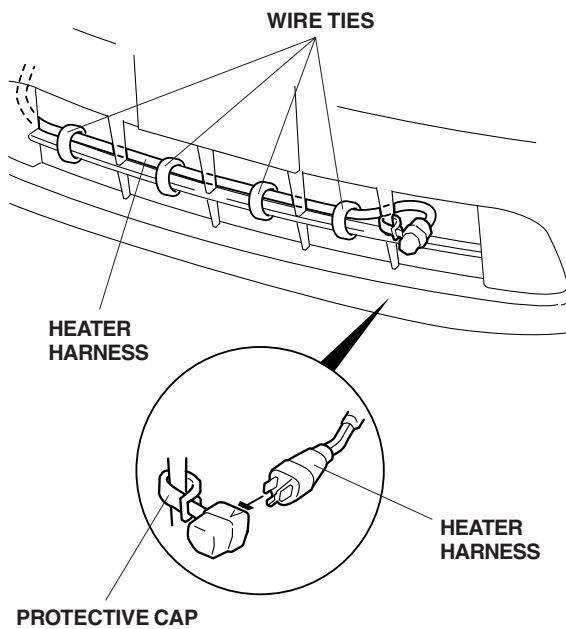

14. Attach the protective cap to the front bumper grille, and plug the connector of the heater harness into the protective cap.

15. Reinstall the resonator removed in step 2.
16. Reinstall the radiator drain plug.
17. Fill the system with the recommended coolant (Honda All Season Antifreeze/Coolant Type 2). Follow the instructions in the service manual.
18. Check the coolant reservoir for correct level and signs of leakage. Repair if necessary.
19. Check that the heater harness is routed properly and all connectors are plugged in.
20. Put the drain bolt (removed in step 6) in the glove box.