



INSTALLATION INSTRUCTIONS

Accessory

FOG LIGHTS
08V31-S5T-112

Application

2005 CIVIC SI

Publications No.

All 27943

Issue Date

AUG 2004

PARTS LIST

Fog light (right)



Fog light (left)



Trim (right)

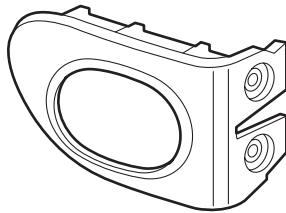

Trim (left)

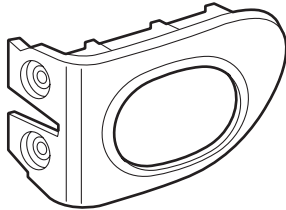

Bracket A (right)



Bracket A (left)

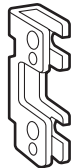

Bracket B (right)

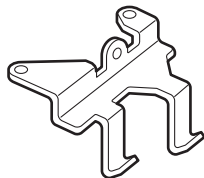

Bracket B (left)

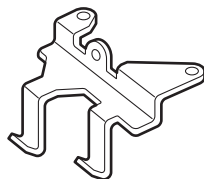

Main harness

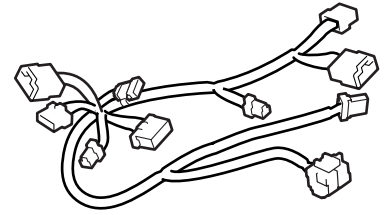

Fog light harness

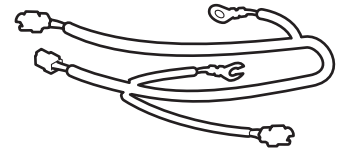

Templates A, B and C

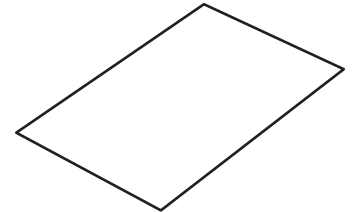

Switch

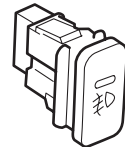

Fuse label

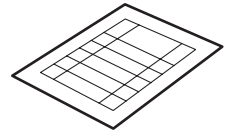

2 Stepped screws



28 Wire ties

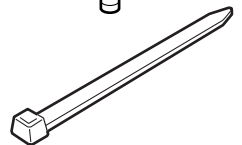

Relay

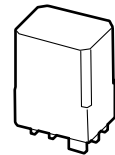

4 Self-tapping screws, 4 x 10 mm



4 Self-tapping screws, 5 x 16 mm



4 Large washer-screws

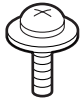

2 Washer-screws



4 Nuts



TOOLS AND SUPPLIES REQUIRED

#2 Phillips screwdriver

Flat-tip screwdriver

Blanket or cardboard

Ratchet

10 mm Sockets

Drill

3 mm, 5 mm, and 10 mm Drill bits

Diagonal cutters

Pushpin

Utility knife

Felt-tip pen

Gloves

Scissors

Masking tape

Piece of wire

Eye protection (face shield, safety goggles, etc.)

File

Illustration of the Fog Lights Installed on the Vehicle

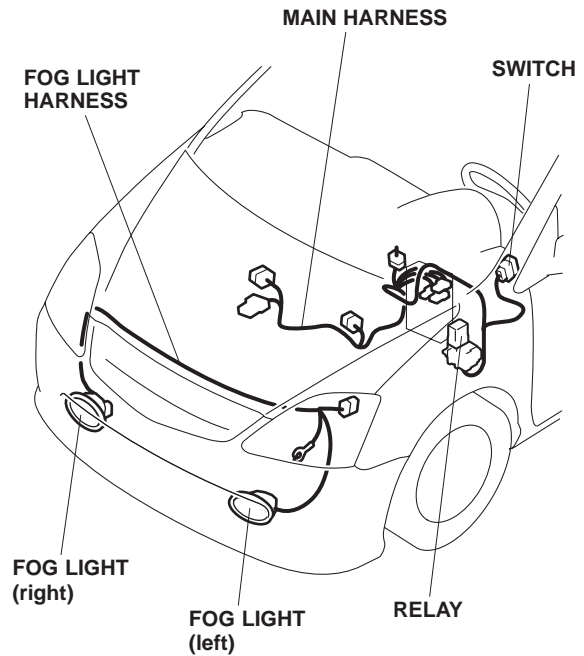

INSTALLATION

Customer Information: The information in this installation instruction is intended for use only by skilled technicians who have the proper tools, equipment, and training to correctly and safely add equipment to your vehicle. These procedures should not be attempted by “do-it-yourselfers.”

1. Make sure you have the anti-theft code for the radio, then write down the radio station presets.
2. Disconnect the negative cable from the battery.
3. Remove the front bumper:
 - Remove the four clips from the top of the bumper.
 - Remove the six clips and two self-tapping screws from the bottom of the bumper.
 - Remove the two self-tapping screws from both ends of the bumper.
 - Pull out on both ends of the bumper to release the clips, then pull the bumper forward so that you can reach behind it, and disconnect the side marker lights.
 - Place the bumper on a blanket or a piece of cardboard to protect it while you are installing the fog lights.

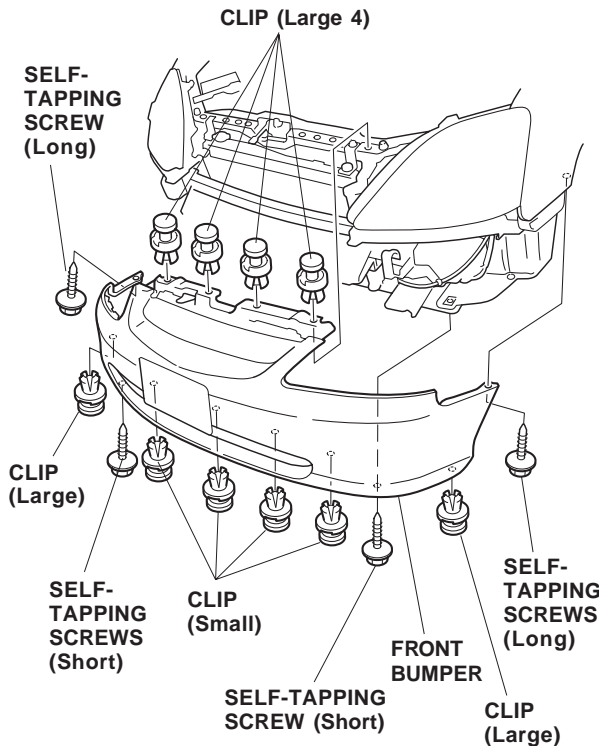

4. Using scissors, cut out template A, and place it on the bumper grille by aligning the upper edge with the left upper edge of the bumper grille as shown. Tape the template. Using a pushpin, mark the bumper grille as indicated on the template.

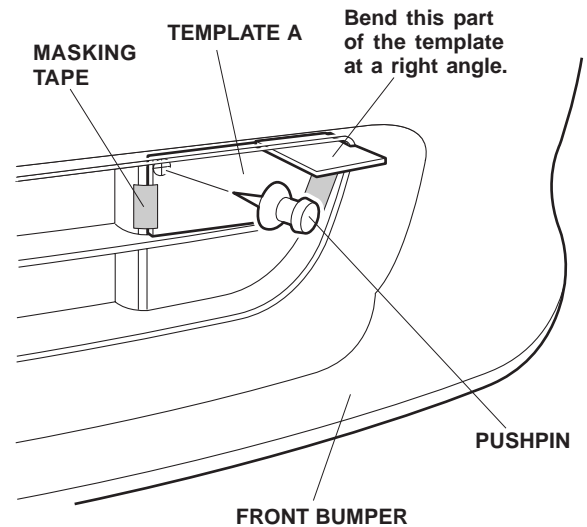

5. Cut out template B, and tape it onto the bumper grille by aligning the lower edge with the left lower edge of the bumper grille as shown. Using a pushpin, mark the bumper grille as indicated on the template.

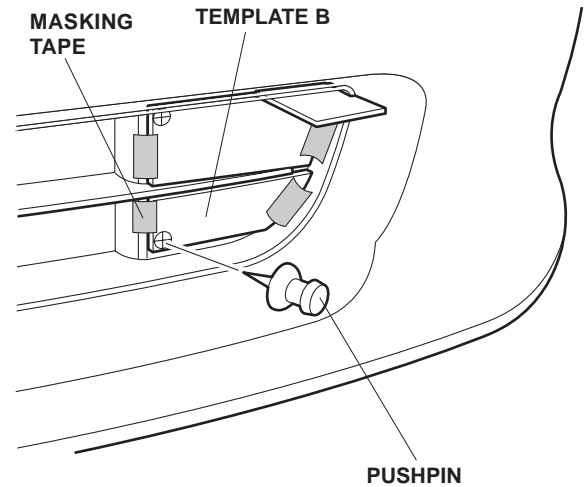

- Cut out the template C, and tape it onto the front bumper by aligning the inner edge with the left edge of the bumper grille as shown. Using a pushpin, mark the bumper grille as indicated on the template. Using a felt-tip pen, mark the bumper grille along the outer edge of the template as shown.

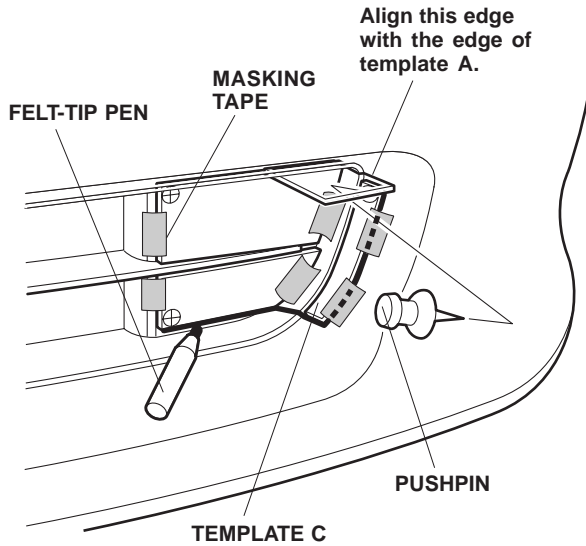

- Remove templates A, B and C. While wearing eye protection, drill a 10 mm hole through each of the three marks. First drill with a 3 mm bit, then finish with a 10 mm bit.

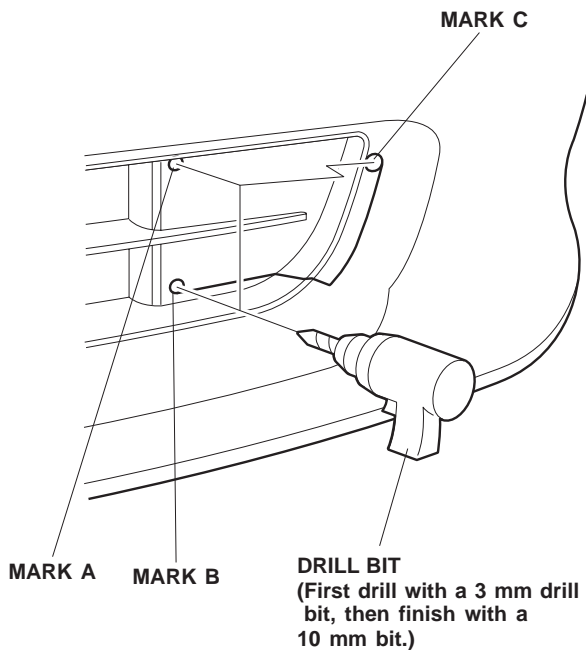

- Using a utility knife, cut out the edges of the bumper grille as marked:

- Cut the upper and lower edges at right angles as viewed from the front.
- Cut the right edge parallel with the vertical line of the bumper grille.

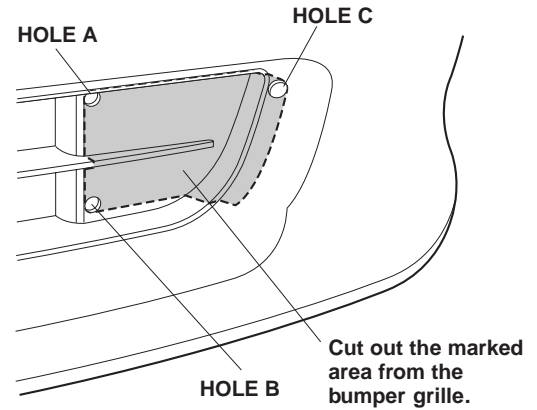

- Inside the front bumper, temporarily slide the two spring nuts onto the bumper grille as indicated by the guide lines. Using a pushpin, mark the bumper grille at each of the two holes in the spring nuts. Remove the spring nuts.

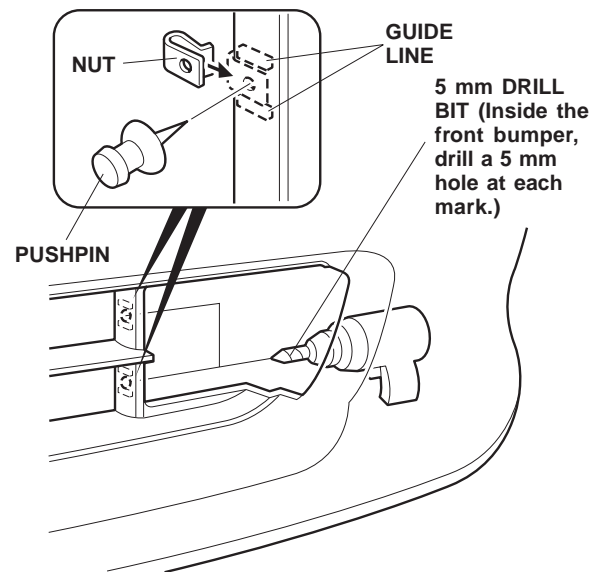

- While wearing eye protection, drill a 5 mm hole through the bumper grille at each mark. After drilling, remove any burrs from the edges of the holes with a file.
- Prepare the bumper for the right fog light by turning over the templates and repeating steps 4 through 10 on the right side.

- Slide the two spring nuts onto the bumper grille, then loosely install the two self-tapping screws. Position bracket A between the bumper grille and the heads of the self-tapping screws, then tighten the self-tapping screws securely.

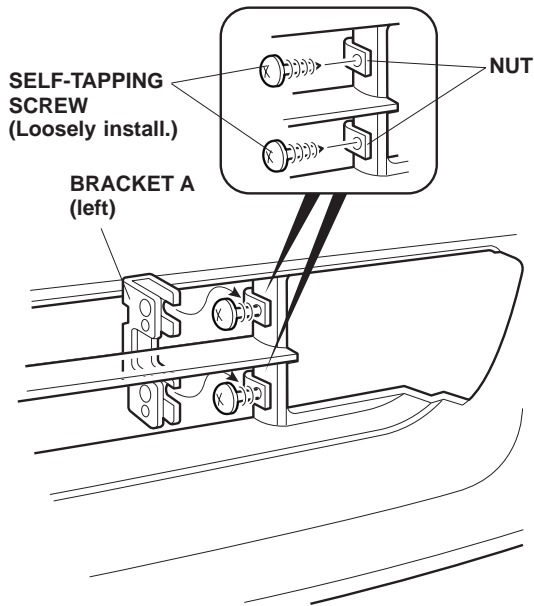

- Position the fog light on the fog light trim, then attach bracket B to the fog light trim with two 4 x 10 mm self-tapping screws.

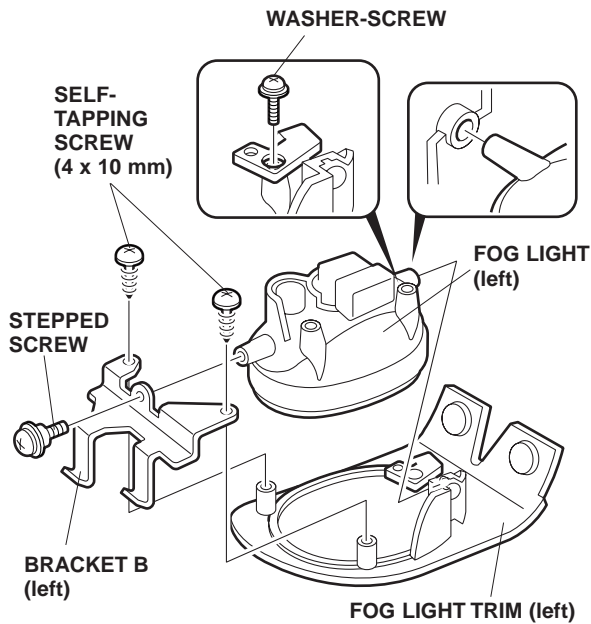

- Install one stepped screw and one washer-screw to secure the fog light to bracket B and fog light trim.

- Position the fog light and fog light trim assembly on the bumper grille, and install two large washer-screws.

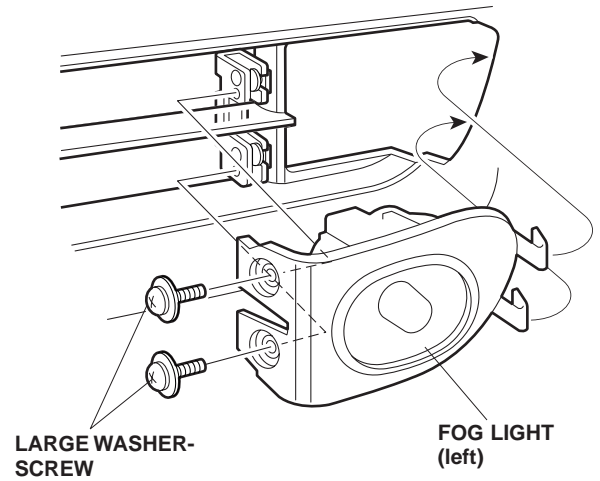

- Repeat steps 12 through 15 for the right fog light.
- Remove the seven clips and three self-tapping screws that fasten the left front inner fender to the fenderwell, and pull the inner fender down.

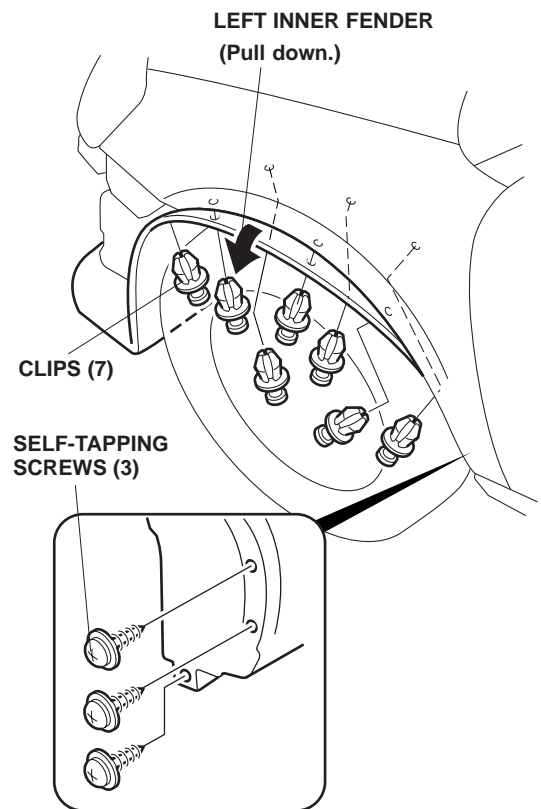

18. Remove the dashboard lower cover on the driver's side. Turn the knob counterclockwise, and release the five retaining tabs.

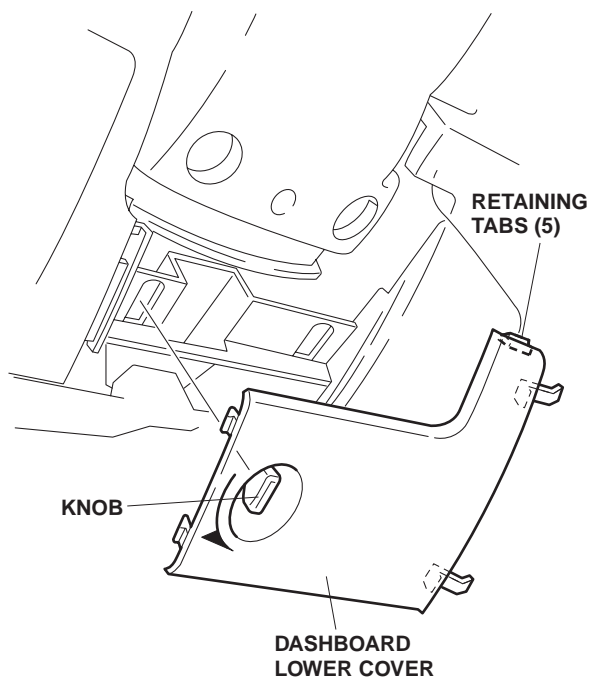

19. Remove the driver's dashboard under cover. Turn the knob clockwise, and release the clip and one retaining tab.

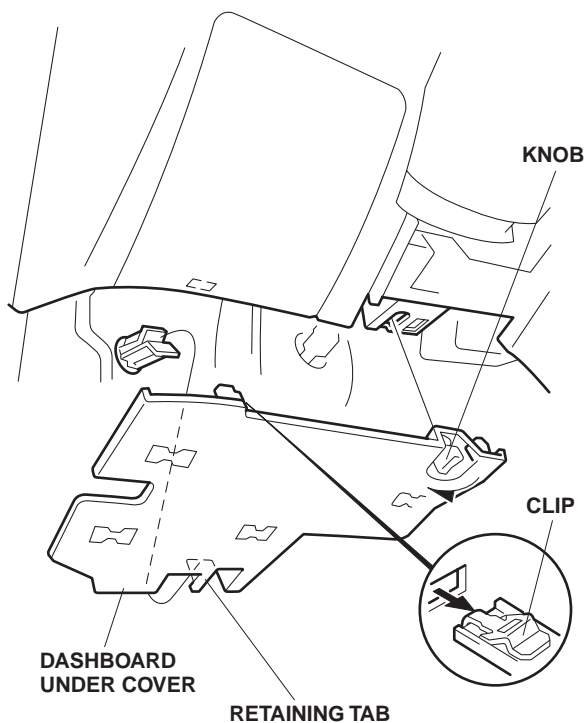

20. Remove the two self-tapping screws that secure the top of the pocket, and remove the pocket by removing the two clips and one retaining tab.

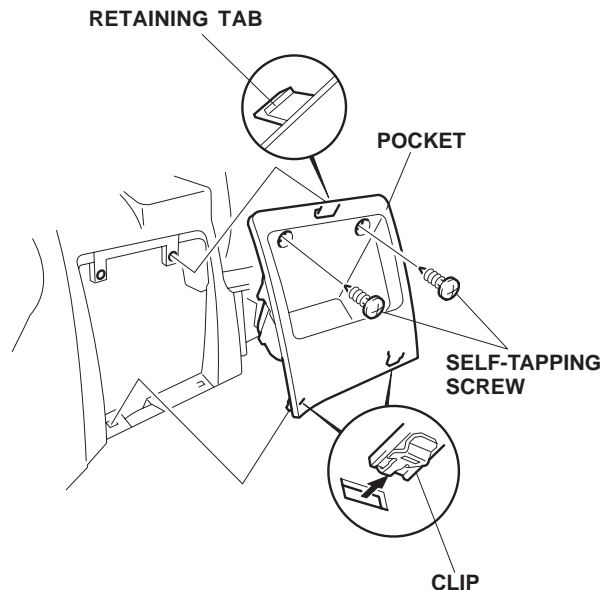

21. Remove the switch lid from the instrument panel.

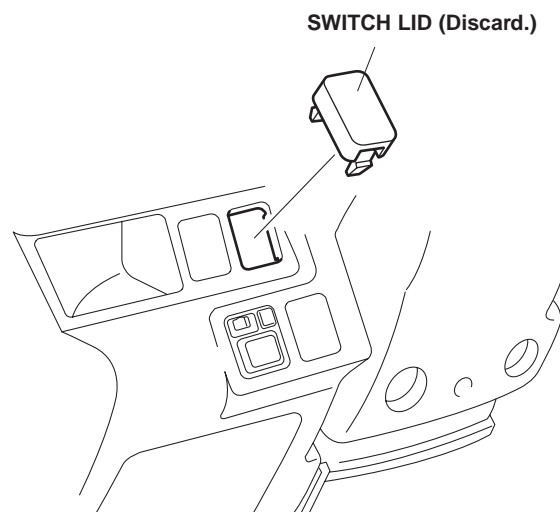

- Pull the passenger's side lower cover down to release the three clips, then pull it out toward you to release the two bosses. Remove the lower cover.

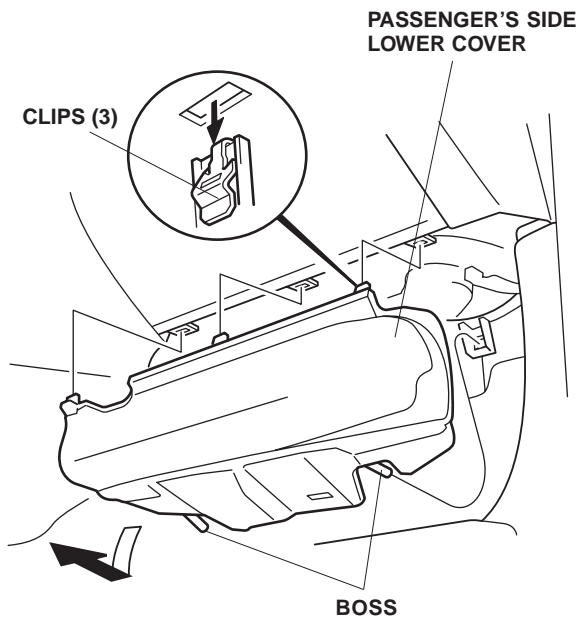

- Plug the relay (gray) into the relay block on the main harness.

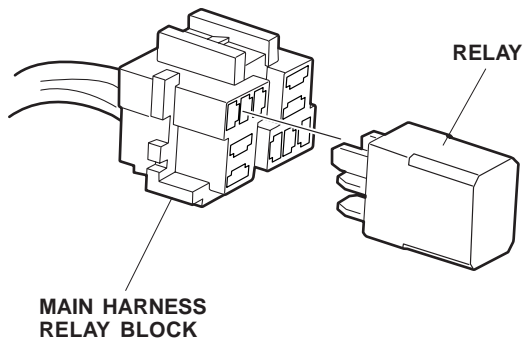

- Slide the relay block of the main harness onto the vehicle bracket.

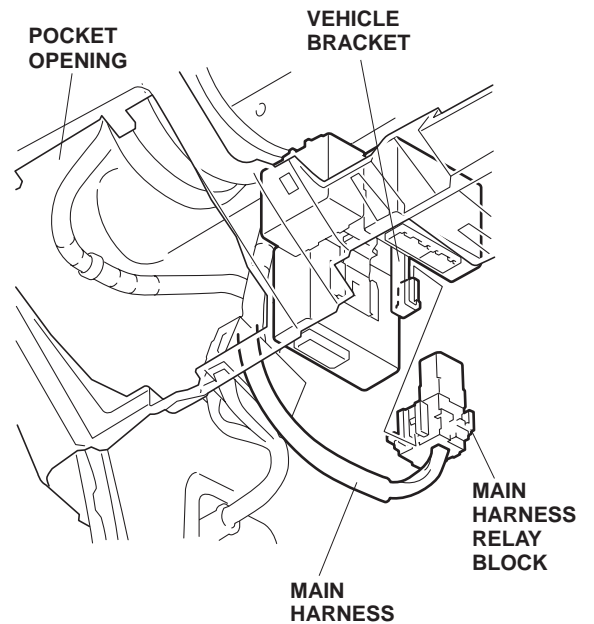

- Pull the 5-pin connector of the main harness out through the switch hole, then plug it into the switch. Install the switch in the switch hole.

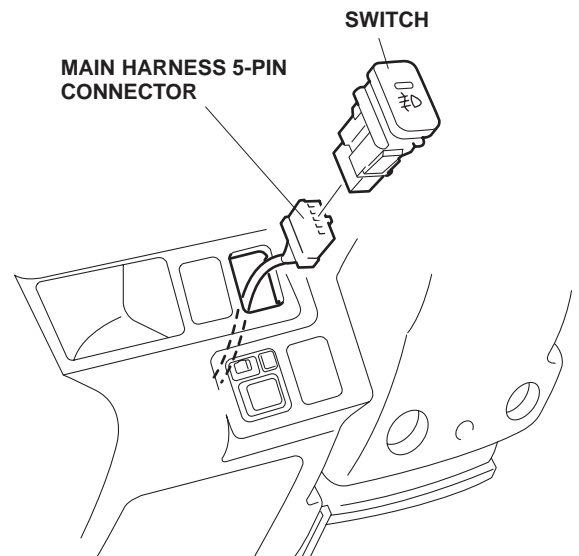

26. Attach the fuse label (20A) to the fuse case of the main harness.

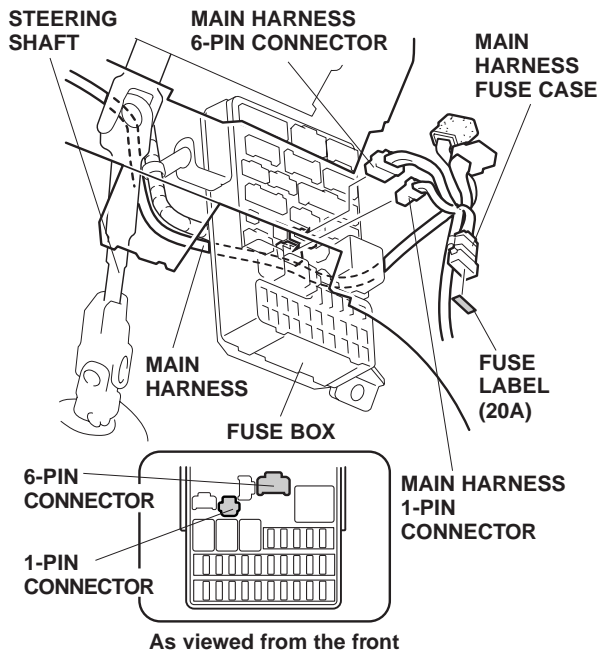

27. Route the main harness to the right, over the steering shaft, and plug the 1-pin and 6-pin connectors into the fuse box.
28. Unplug the vehicle 12-pin connector from the fuse box, and plug the 12-pin connectors of the main harness in between.

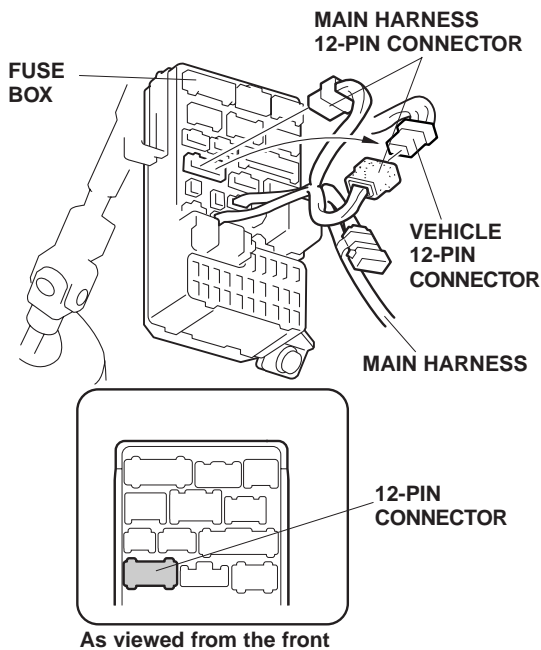

29. Route the 10-pin connector of the main harness behind the center console to the passenger's side.

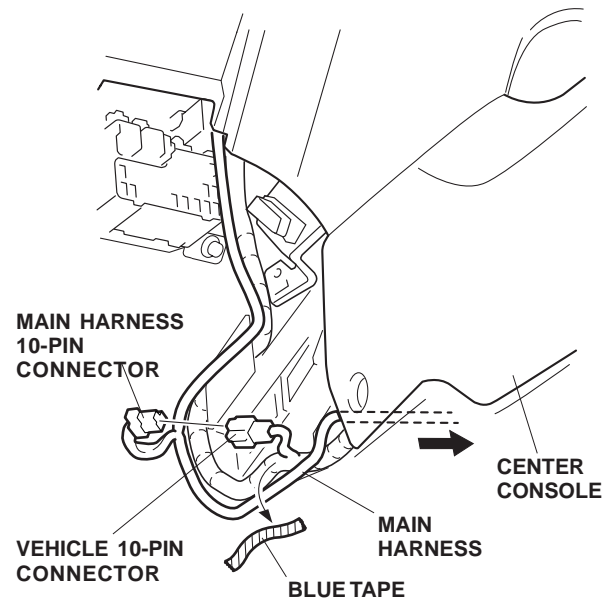

30. Behind the center console, locate the 10-pin connector blue-taped to the vehicle harness, and remove the blue tape to free the connector. Connect the 10-pin connector you just freed to the 10-pin connector of the main harness.
31. On the passenger's side, locate the vehicle 10-pin and 4-pin connectors, and disconnect them. Slide the 4-pin connector off the 10-pin connector as shown.

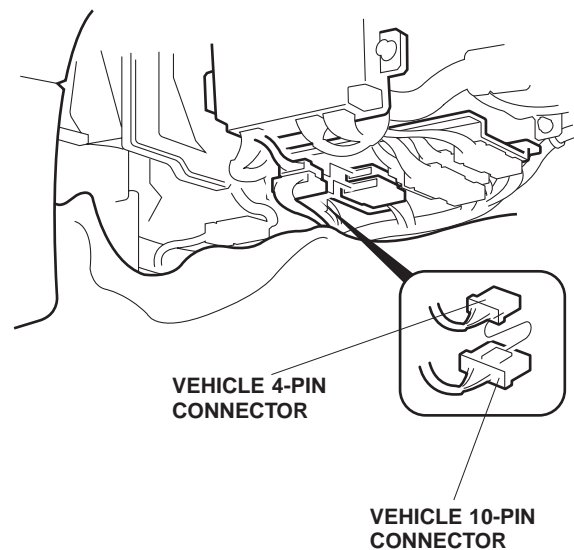

32. Slide the vehicle 4-pin connector you just removed onto the 10-pin connector of the main harness, then reconnect the harness.

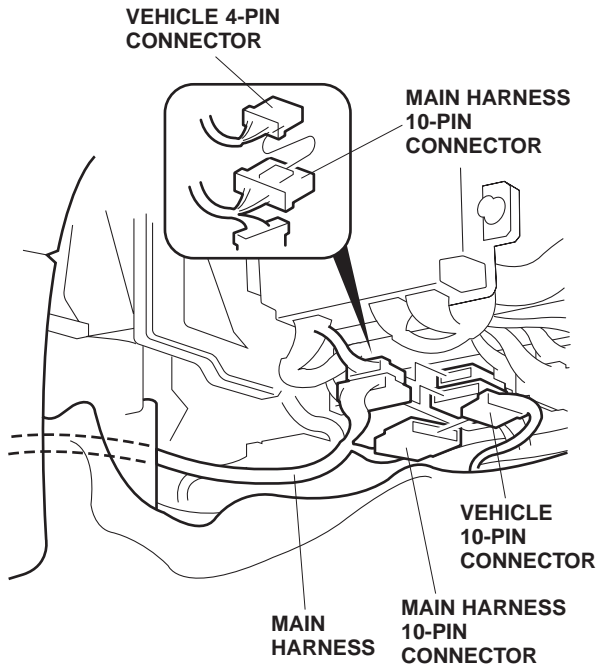

33. On the passenger's side, secure the main harness to the vehicle harness with three wire ties in the areas shown.

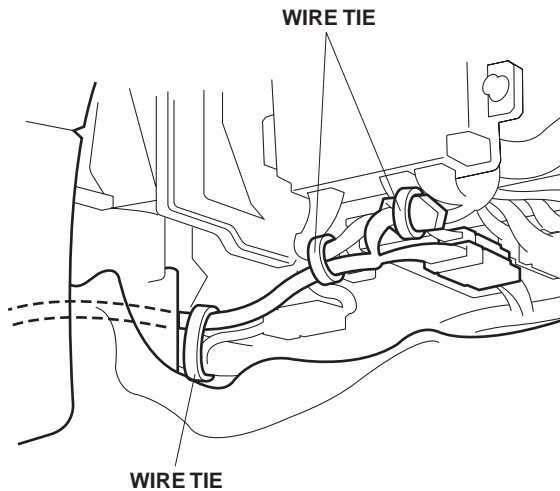

34. On the driver's side, secure the main harness to the vehicle harness with eight wire ties in the areas shown. This harness is near the brake pedal bracket, about 150 mm (6 in.) above the steering shaft.

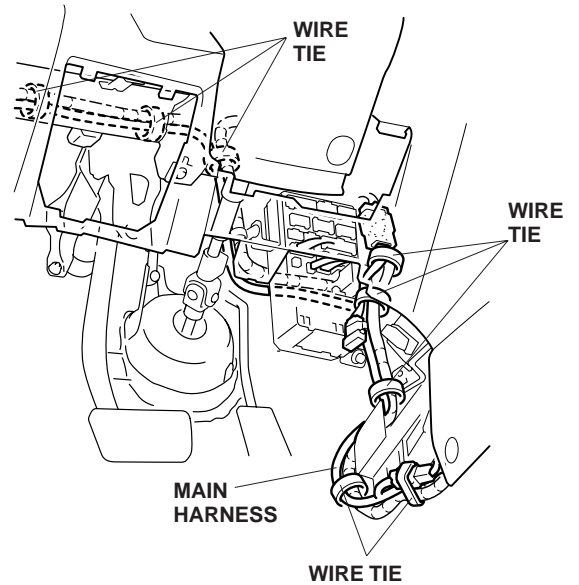

35. At the left (driver's side) kick panel, secure the main harness to the vehicle harness with three wire ties in the areas shown.

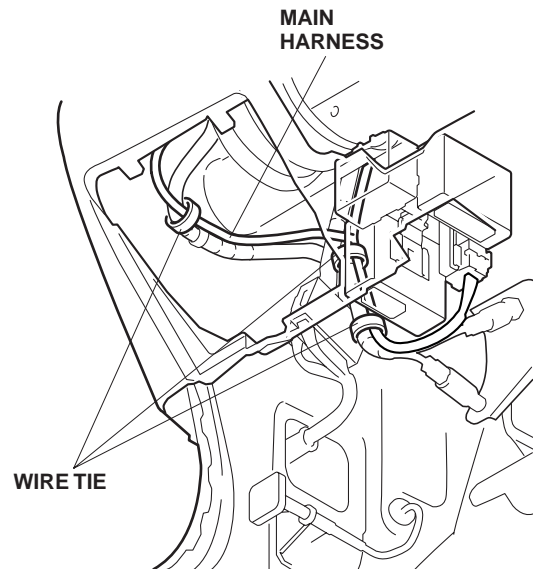

36. Check that the negative cable was already disconnected from the battery, then disconnect the positive (+) cable from the battery. Remove the battery and the battery bracket.

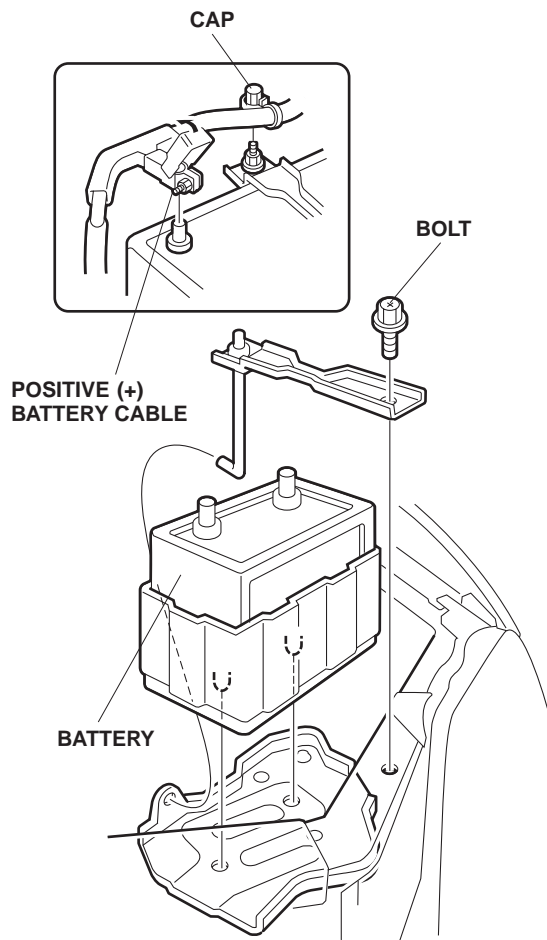

37. Remove the five harness clips from the front bulkhead to free the vehicle harness.

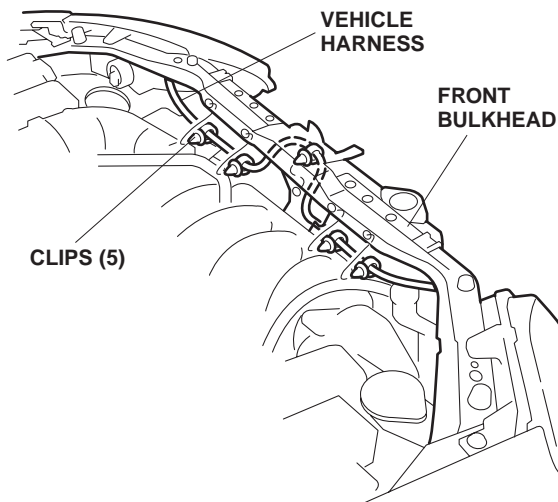

38. Behind the left headlight, locate the 1-pin connector blue-taped to the vehicle harness, and remove the blue tape to free the connector. Connect the 1-pin connector you just freed to the 1-pin connector of the main harness, then route the 2-pin connector and the ground terminal of the fog light harness to the left inner fender through the panel hole.

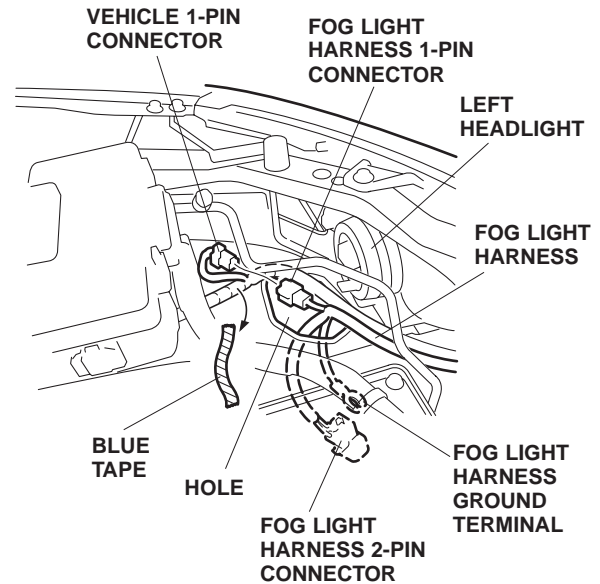

39. Route the other 2-pin connector of the fog light harness to the right, along the vehicle harness, then secure the harness with three wire ties in the areas shown.

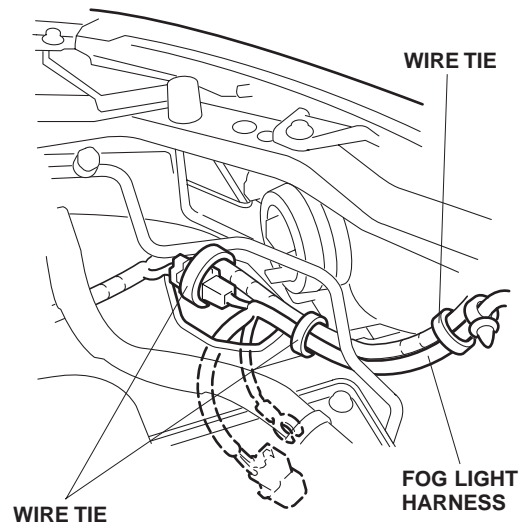

- Attach a piece of wire to the 2-pin connector of the fog light harness. Using the wire, route the connector through the bulkhead, around the latch and back through the bulkhead, then along the vehicle harness, toward the right headlight.

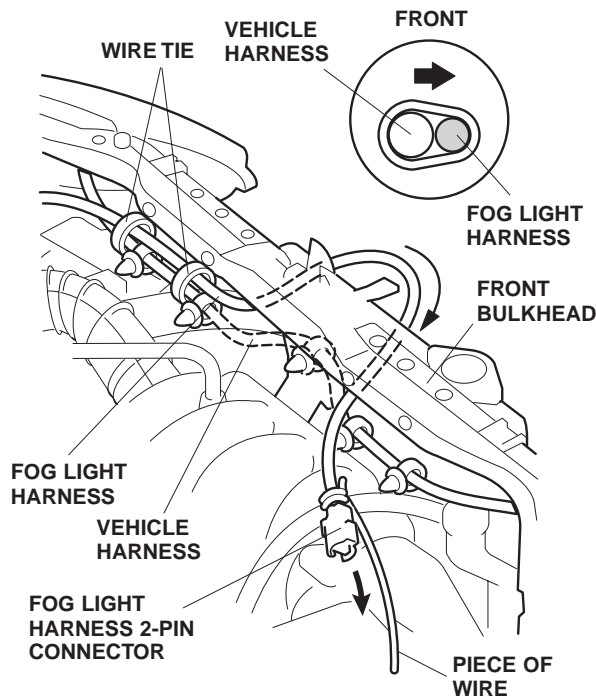

- On the left side of the bulkhead, secure the fog light harness to the vehicle harness with two wire ties.
- Route the fog light harness down between the right bulkhead and the radiator, then secure it to the vehicle harness with three wire ties.

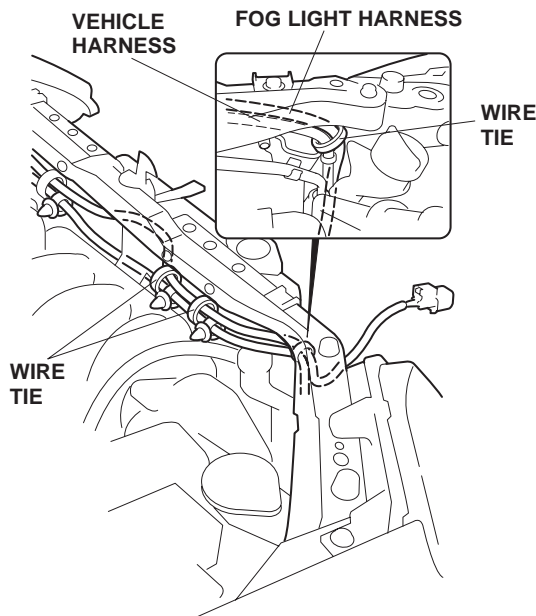

- Secure the fog light harness to the vehicle harness with two wire ties.

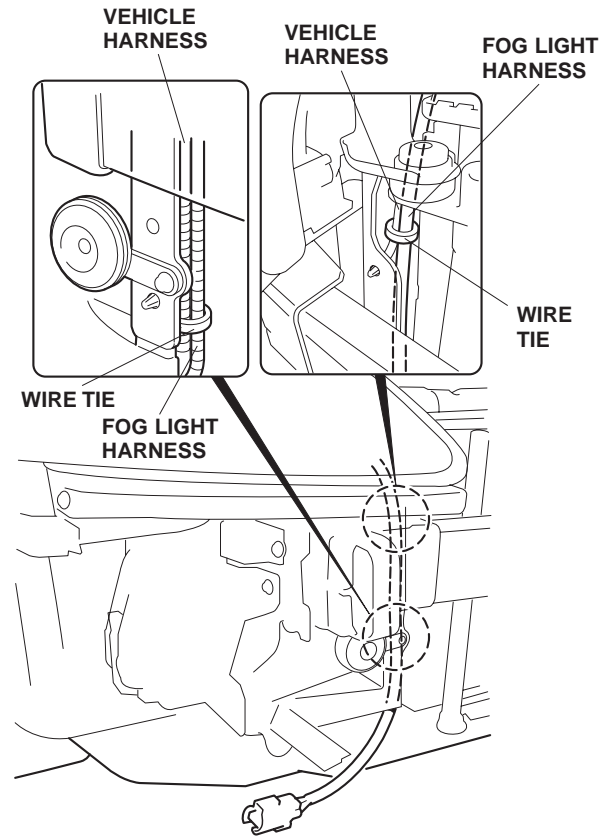

44. Loosen the central ground bolt, and secure the fog light harness ground terminal with this ground bolt.

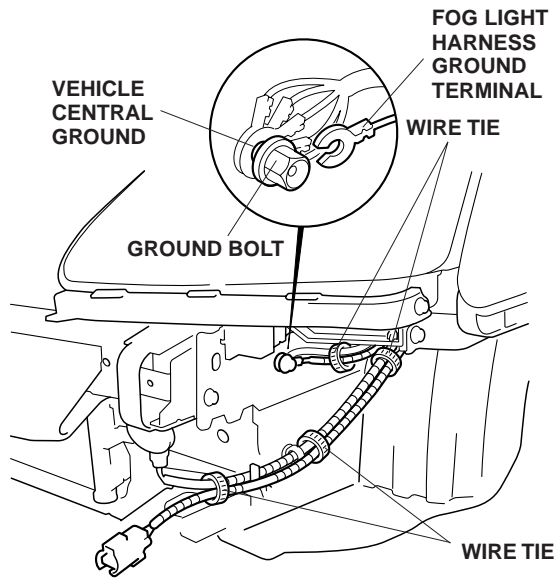

45. Secure the fog light harness to the vehicle harness with four wire ties.
46. While holding the front bumper near the front of the vehicle, plug the right and left 2-pin connectors of the fog light harness into the right and left fog lights.

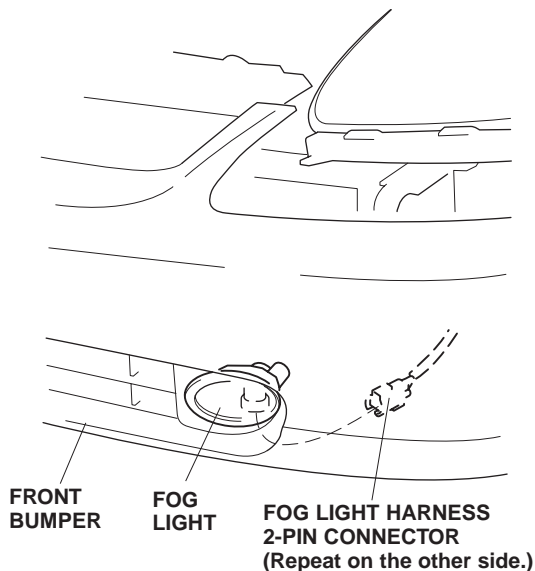

47. Plug in the side marker lights, and reinstall the front bumper. Check that all clips and retaining tabs are installed securely.

48. Check that all wire harnesses are routed properly and all connectors are plugged in.
49. Reinstall all removed parts.
50. Reinstall the battery and battery bracket. Reconnect the positive cable and then the negative cable to the battery.
51. Reset the clock, and reset the radio station presets.
52. Test the operation of the accessory socket/cigarette lighter.
53. Do the engine control module (ECM) idle learn procedure:
 - Make sure all electrical items (A/C, audio, rear defogger, lights, etc.) are off.
 - Start the engine, and hold it at 3,000 rpm with no load (in Neutral) until the radiator fan comes on.
 - Let the engine idle for 5 minutes with the throttle fully closed.

NOTE: When the radiator fan comes on, do not include its running time in the 5 minutes.

NOTE: Whenever the battery is disconnected, the driver's window AUTO function is disabled.

54. Start the engine. Push down on the driver's window switch until the window is fully open.
55. Pull up on the driver's window switch to close the window completely, then hold the switch for 2 seconds.
56. Lower and raise the window to check operation of the driver's window AUTO function.

USE AND CARE

How to Operate Fog Lights

1. Turn the light switch to the "on" position (headlights on low beam).
2. Press the fog light switch (indicator is on).
3. If the fog lights don't come on, check the fuse and all the connectors, including the ground cable and the fusible link.

NOTE: The fog light lenses can cloud when the outside temperature is cold; this is normal and should go away in warm weather.

Fog Light Aiming Adjustment

Adjust the fog lights:

- Adjust the aim according to local laws and regulations.
- To adjust, turn the aiming adjustment screw in or out until the correct aim is obtained.

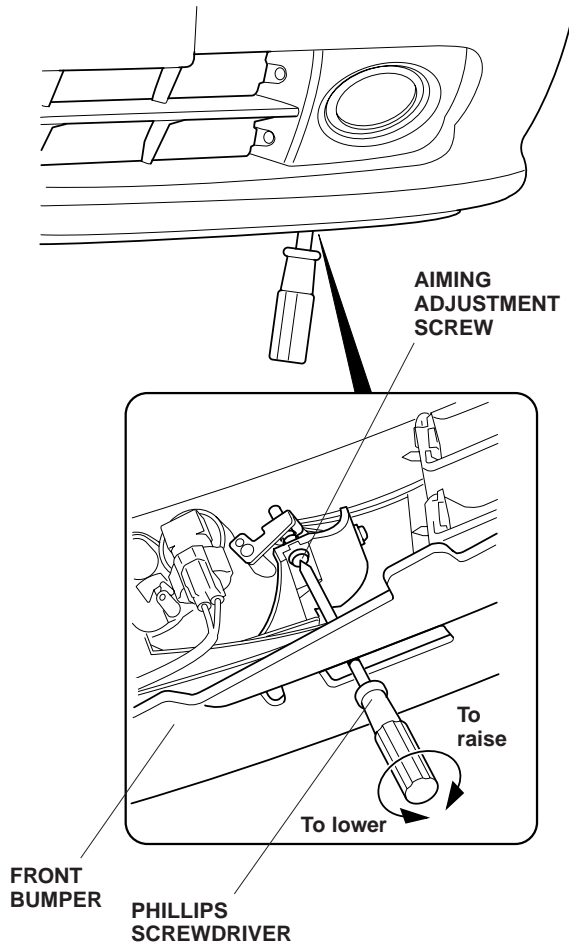

Replacing the Bulb

1. Remove the two washer-screws that fasten the fog light, and pull the light out toward you.
2. Unplug the connector from the fog light, then remove the fog light assembly.

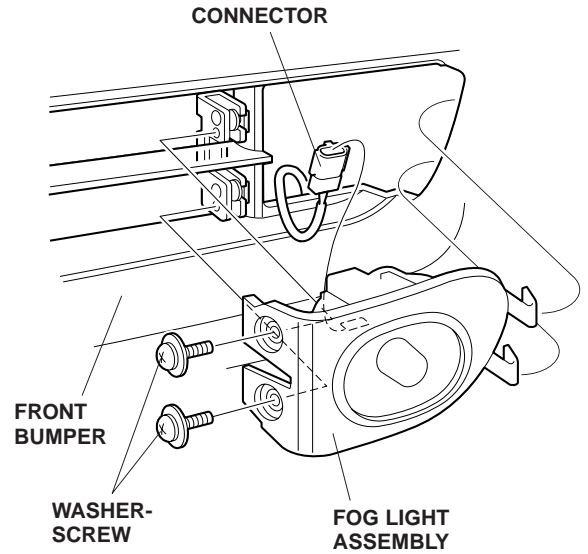

3. Remove the bulb.

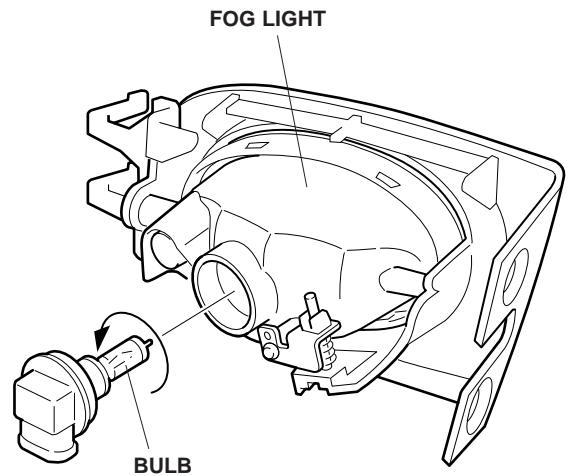

4. Install the new bulb into the fog light assembly:

- Use only a Honda halogen light bulb of specified wattage.

Rating: 12V 55W H11 Halogen Light Bulb
(P/N 33165-S5A-0030)

- Do not touch the bulb. Oily or greasy substances on the bulb can shorten its service life due to the heat produced when the bulb is turned on. If the bulb is accidentally touched, wipe it clean with a clean, soft cloth dampened with isopropyl alcohol or a mild detergent solution.

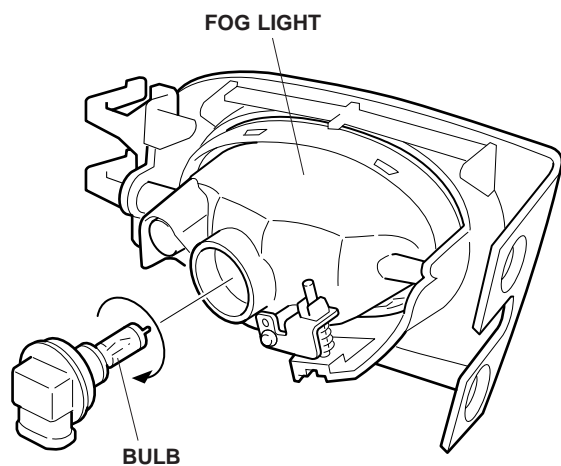

5. Reinstall the fog light, and reconnect the connector:

- Check that the wire harnesses are not pinched.
- Make sure you tighten the washer-screws securely.

6. Check the operation of the fog lights; adjust the aiming if necessary.

CIRCUIT DIAGRAM

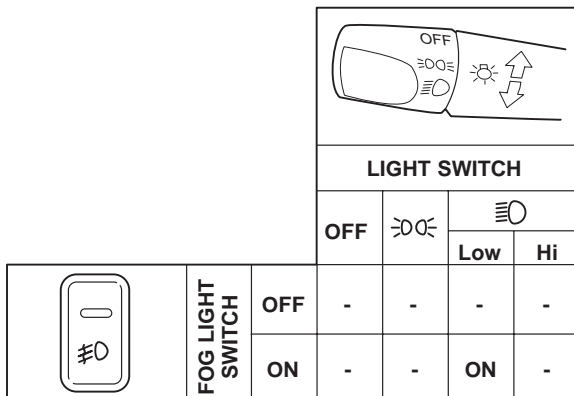
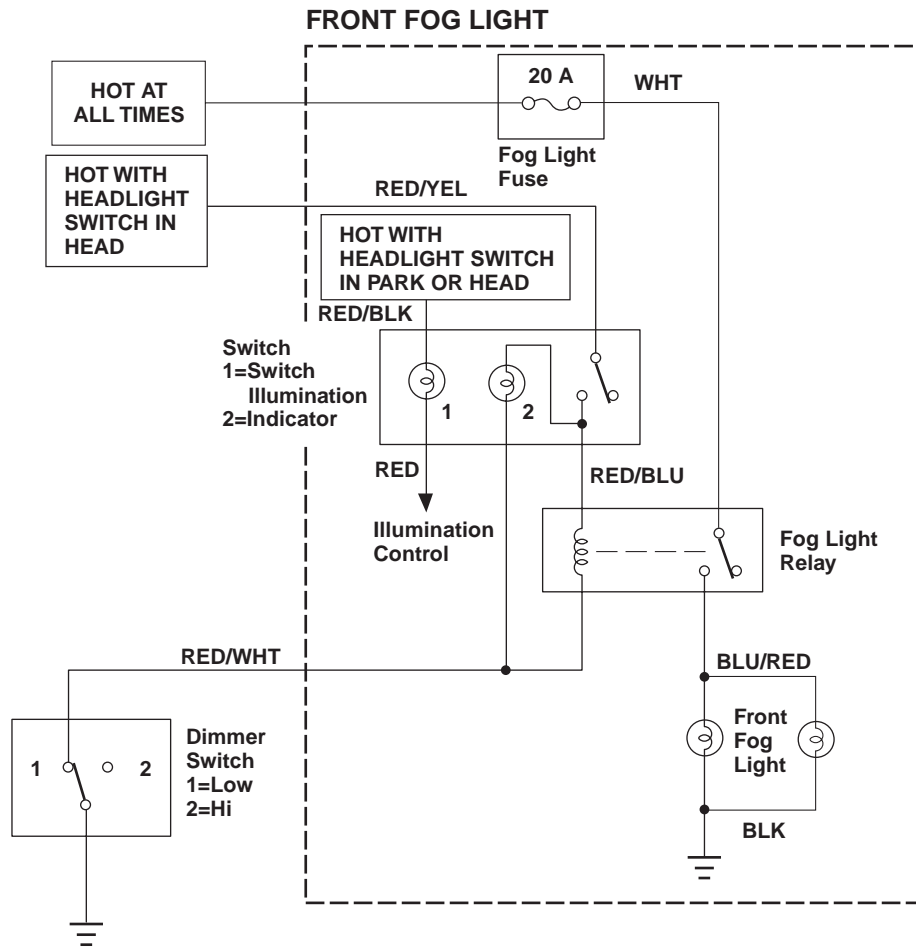

BLK	BLACK	BRN	BROWN
YEL	YELLOW	ORN	ORANGE
BLU	BLUE	PUR	PURPLE
GRN	GREEN	NAT	NATURAL
RED	RED	PNK	PINK
WHT	WHITE	GRY	GRAY
LT BLU	LIGHT BLUE	LT GRN	LIGHT GREEN