

PARTS LIST

Right door body side molding

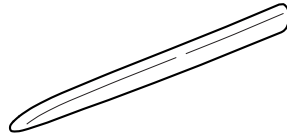

Right quarter panel body side molding

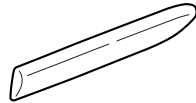

Left door body side molding

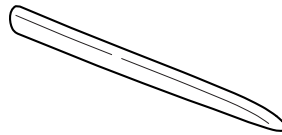

Left quarter panel body side molding

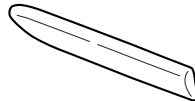

Template

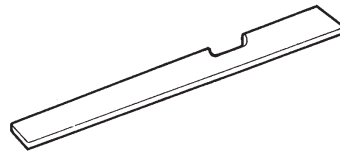

TOOLS AND SUPPLIES REQUIRED

Metric tape measure

Clean, lint-free wiping cloths

50/50 Water/isopropyl alcohol mix

Masking tape

Felt-tip pen

INSTALLATION

NOTE:

- This body side molding kit should be installed only when the ambient air temperature is 60°F (15°C) or above.
- If the vehicle has been repainted, let the paint cure for at least 24 hours before you install the molding.
- Do not remove the backing from the molding until you are ready to stick that molding in place.
- Do not install any molding that shows the backing peeled away, contaminated or damaged adhesive.
- Do not touch the body where the molding will attach. If you do, rewash that area as described under "Preparing the Molding Areas."
- To allow the adhesive to cure, do not wash the vehicle for 24 hours.

Installing the Template

1. Using a tape measure and a felt-tip pen, measure and mark the left door in the area shown

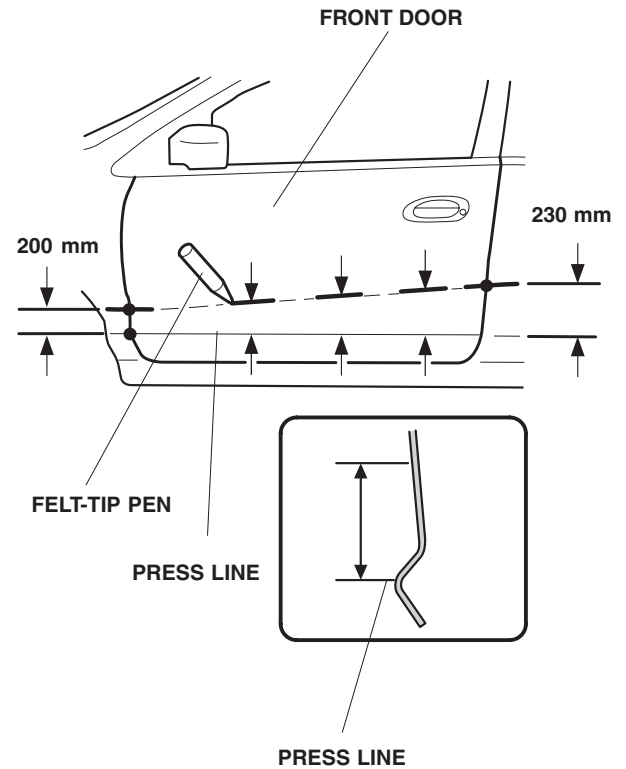

2. Position the template onto the left driver's door, aligning the template with the marks you made.
3. Tape the bottom and sides of the template to the door.

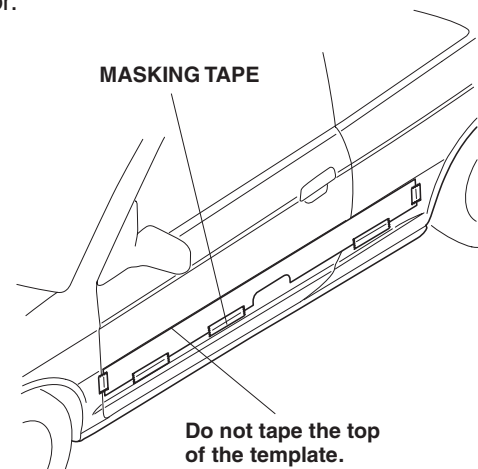

Preparing the Molding Areas

- Before installing each molding piece, clean the molding area on the body with a lint-free cloth dipped in a 50/50 mixture of water and isopropyl alcohol. Keep checking the cloth; when it looks dirty, turn it over or replace it with a clean one. Then, just before installing the molding piece, wipe the area with a dry, lint-free cloth.

Installing the Moldings

- Before removing the backing from the molding, trial-fit the molding so you become familiar with the correct location of the molding piece. Hold the molding piece against the body, and align its lower edge with the upper edge of the template.
- Peel back about 3 inches of the backing from the rear edge of the molding, and fold it diagonally toward the outside. Attach the backing to the front of the molding using masking tape.

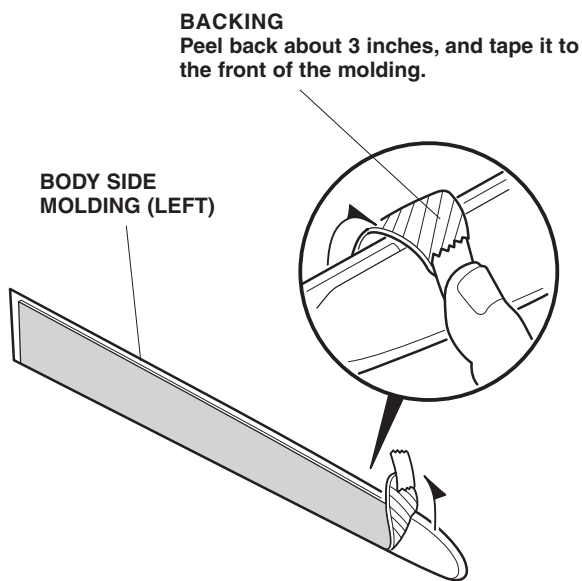

- Attach the rear edge of the molding to the edge of the door, and continue holding the molding in alignment. Carefully pull out about 6 inches of backing from under each side, then press the molding into place. Repeat as necessary, 6 inches at a time, until the entire length of molding is attached. Do not “stretch” the molding by stroking or smoothing it into place; instead roll or “walk” your hand or fingers against it from back to front.

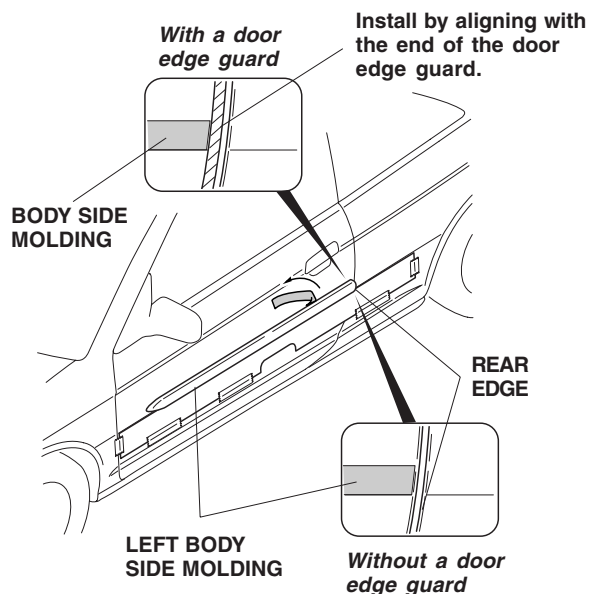

- Install the left quarter panel body side molding as described in steps 4 through 7, except that the molding starts 2 mm back from the edge of the door.

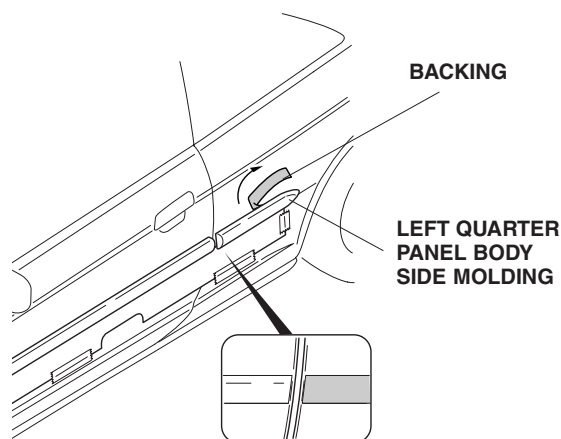

- Remove the template.
- Repeat steps 1 through 9 to install the door moldings on the right side (passenger's) of the vehicle.

NOTE: After the body side molding is installed, tell your customer not to wash the vehicle for 24 hours to give the adhesive time to cure.