



INSTALLATION INSTRUCTIONS

Accessory

TRUNK SPOILER

Application

2005 CIVIC 4-DOOR

Publications No.

All 27894

Issue Date

AUG 2004

PARTS LIST

Trunk spoiler

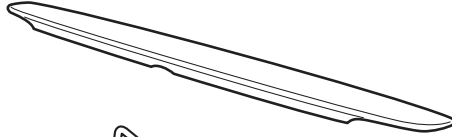

Left trunk spring
(not marked)

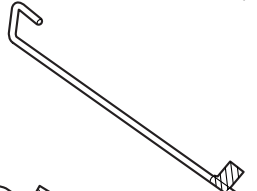

Right trunk spring
(marked yellow)

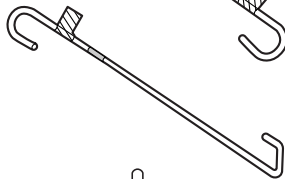

4 Bolts



6 Flange nuts



Template

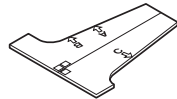

TOOLS AND SUPPLIES REQUIRED

Eye protection (face shield, safety goggles, etc.)

Drill

3 mm and 8 mm Drill bits

Drill stop

File

Center punch

Touch-up paint

Ratchet

10 mm Socket

Torque wrench

Gloves

Trunk spring installer/remover:

T/N 07AAE-SDAA100

Felt-tip pen

Shop towel

Isopropyl alcohol

Tape measure

Masking tape

INSTALLATION

Customer Information: The information in this installation instruction is intended for use only by skilled technicians who have the proper tools, equipment, and training to correctly and safely add equipment to your vehicle. These procedures should not be attempted by "do-it-yourselfers."

NOTE:

- Be careful not to damage the body paint finish.
- This trunk spoiler kit should be installed only if the ambient air temperature is 60°F (15°C) or above.
- Using isopropyl alcohol on a shop towel, thoroughly clean the areas where the trunk spoiler will attach. Wipe up spilled cleaner at once. Allow the cleaner to dry thoroughly before proceeding to the next step.

Installing the Trunk Spoiler

1. Using a tape measure and a felt-tip pen, measure and mark the trunk lid as shown.

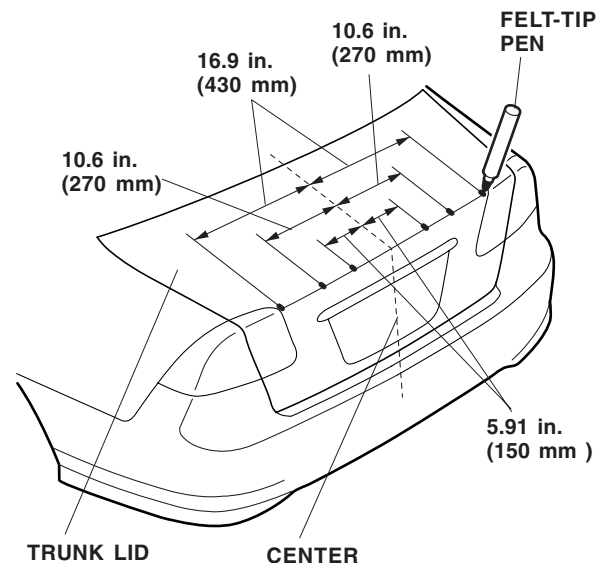

2. Position the template on the left side of the trunk lid.
 - Align location **B** with the first mark from the centerline; mark this location with a felt-tip pen.
 - Align location **A** with the second mark from the centerline; mark this location with a felt-tip pen.
 - Align location **C** with the third mark from the centerline; mark this location with a felt-tip pen.
 - Repeat these steps on the right side of the trunk lid.

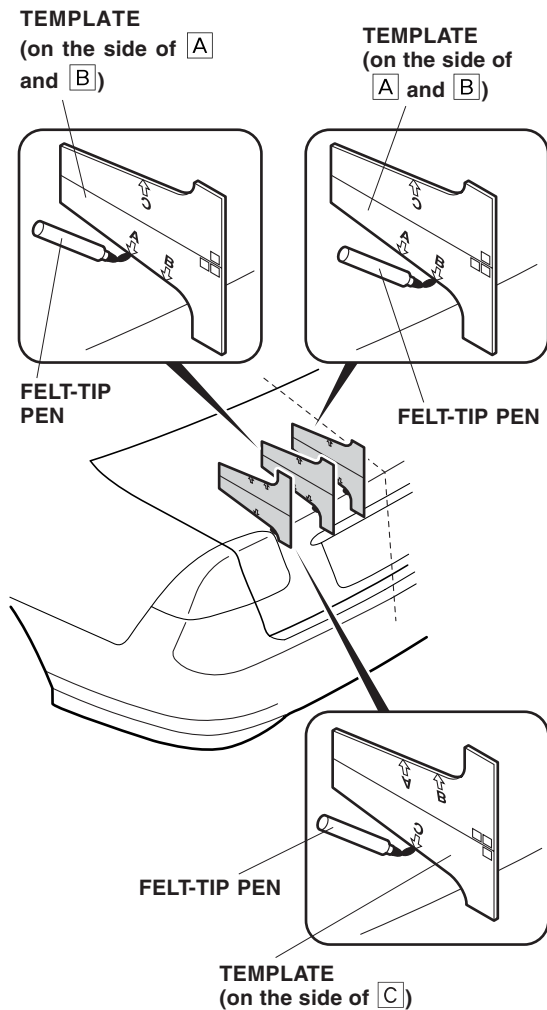

3. Lightly center-punch each mark, and while wearing eye protection, drill an 8 mm hole through each center punched location:
 - Using a drill stop on the end of each bit, first drill with a 3 mm drill bit, and finish with an 8 mm drill bit.
 - After drilling, remove any burrs from the edges of the holes with a file and apply touch-up paint on both sides of the holes. Allow the touch-up paint to dry before proceeding to the next step.

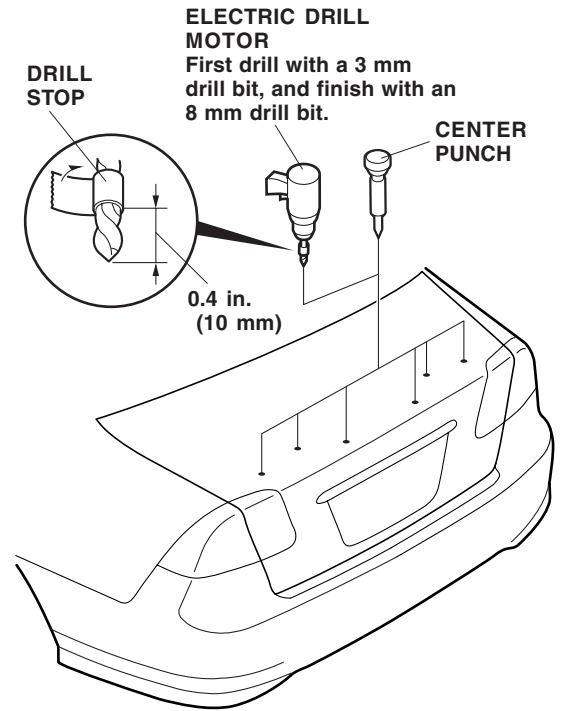

- Slide the bolts onto the holders on the back of the trunk spoiler.

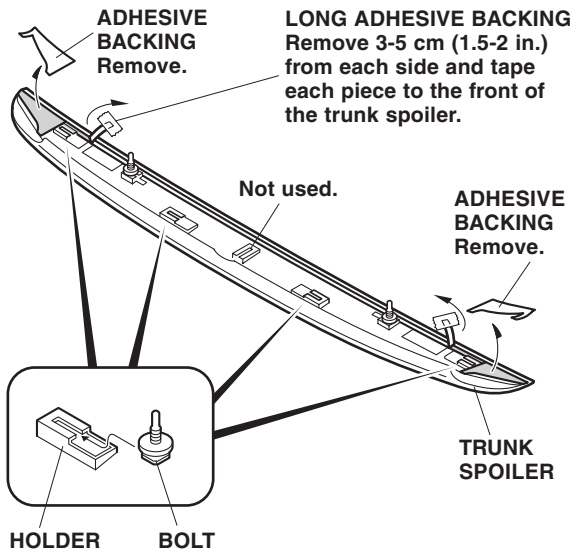

- Remove 1.5-2 in. (3-5 cm) of long adhesive backing from each side of adhesive backing and tape each piece to the front of the trunk spoiler.
- Remove the remaining adhesive backings from the back of the trunk spoiler on each side.
- Using an isopropyl alcohol, thoroughly clean the trunk lid where the adhesive tapes on the trunk spoiler will be attached.

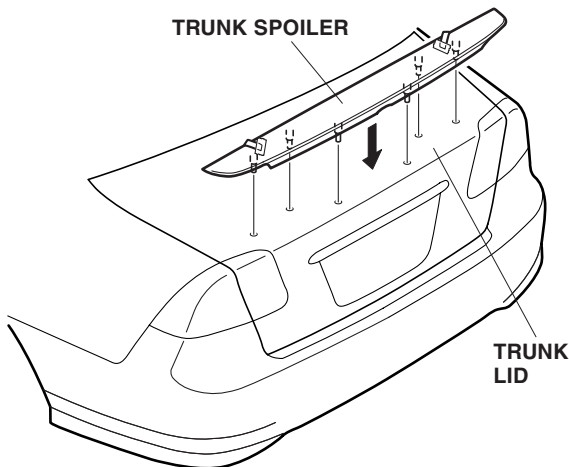

- Fit the trunk spoiler into position on the trunk lid by inserting the bolts through the 8 mm holes drilled in step 5.
- While holding pressure on the trunk spoiler, carefully remove the adhesive backing. After removing the adhesive backing, hold the spoiler firmly against the trunk lid over the adhesive tapes with the palm of your hand.

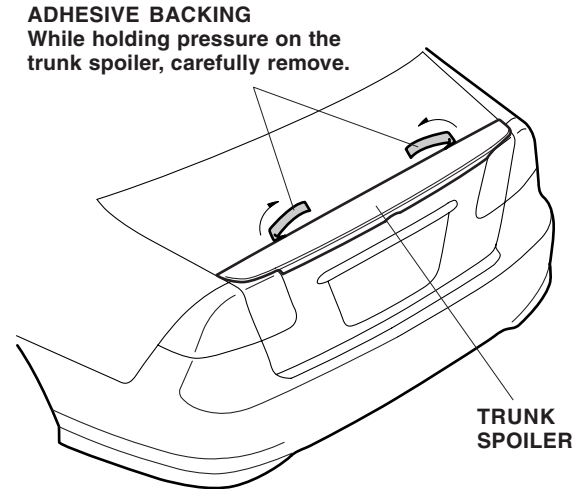

- Open the trunk lid and install a flange nut on the end of each bolt.
Torque: 8.8 N·m (6.5 lbf·ft)

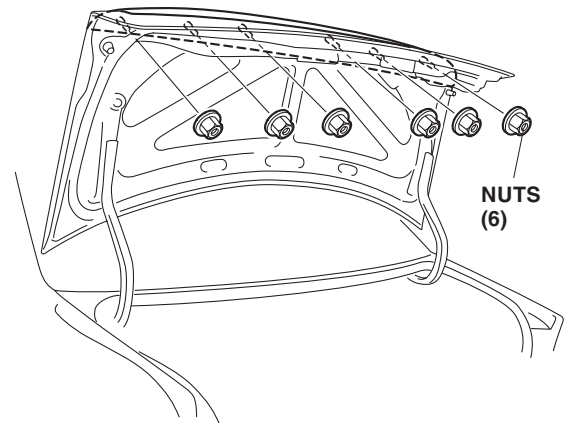

Installing the Trunk Spring

11. Open the trunk lid, and remove the center clip from the trunk springs.

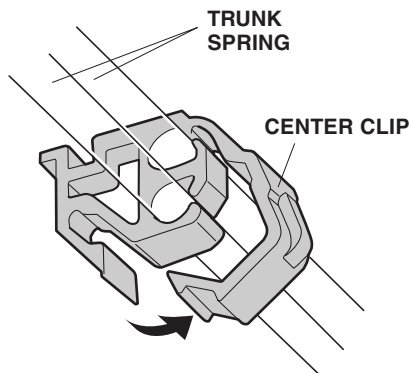

12. With an assistant holding the trunk lid open, remove the old left trunk springs from the trunk hinge arms using the special tool. Wear gloves to protect your hands, and pull the special tool slowly and carefully toward you.

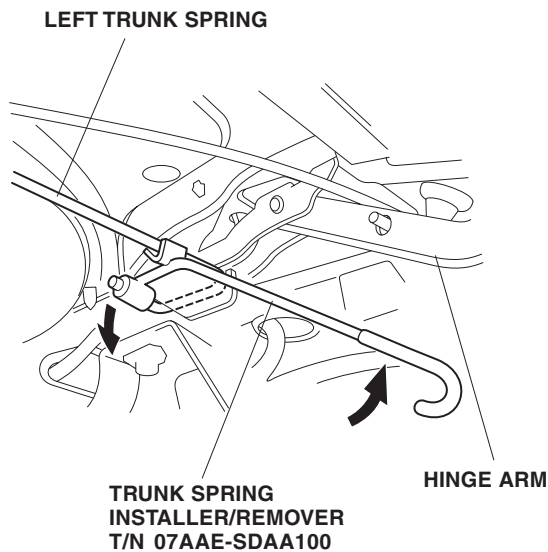

13. Using the special tool, install the right trunk spring and the left trunk spring in the reverse order of removal:

- Install the not-marked spring in the slot in the left (driver's) side trunk hinge arm and to the hinge bracket on the right (passenger's) side of the car; install the yellow-marked spring in the slot in the right (passenger's) side trunk hinge arm and to the hinge bracket on the left (driver's) side of the car.
- Wearing gloves, rotate the tool as you pull it toward you.
- Set the springs in the first notch (original position) of the hinge brackets.

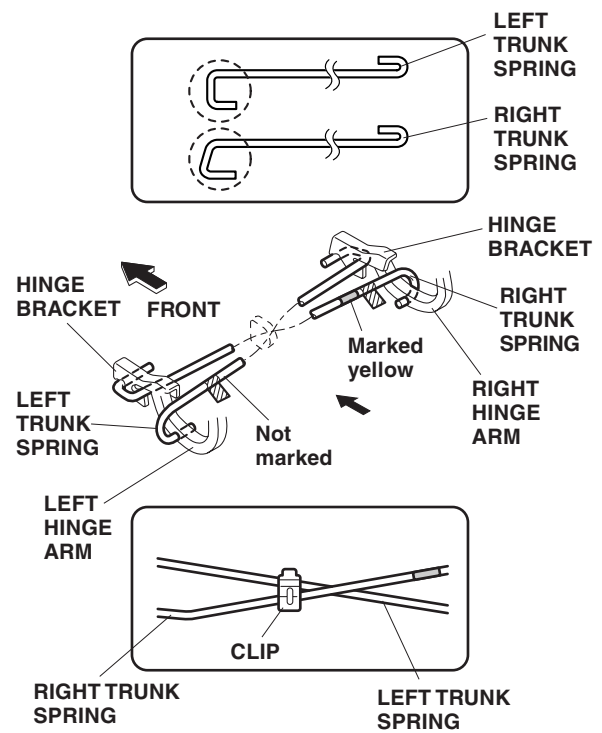

14. Reinstall the center clip on the trunk springs.
15. Reinstall all removed parts. Check that the clips are installed securely.
16. Open the trunk lid, and make sure the trunk lid stays open on its own. If necessary, adjust the trunk springs to the second position.

USE AND CARE

- Handle the spoiler with care. It is not designed to absorb shock or impact.
- Do not open or close the trunk lid by grasping the spoiler.
- Check the spoiler mounting nuts periodically, and retighten them as necessary.