

HONDA

INSTALLATION INSTRUCTIONS

Accessory

SHIFT KNOB
P/N 08U92-S6M-200A

Application

2005 CIVIC 2 DOOR

Publications No.

All 27884

Issue Date

AUG 2004

PARTS LIST

Shift knob

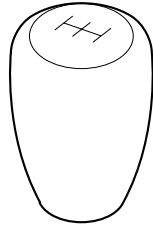

Flange nut



Wire tie

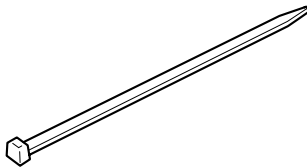

Collar

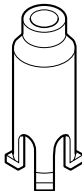

Ring



TOOLS AND SUPPLIES REQUIRED

Flat-tip screwdriver
Phillips screwdriver
14 mm Combination wrench
Utility knife
Diagonal cutters
Shop towel

INSTALLATION

1. Push down the plastic top of the boot with both hands, and remove the shift knob by turning it counterclockwise.

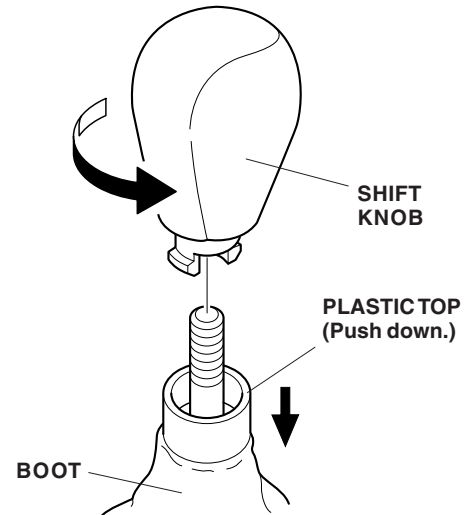

2. Using a flat-tip screwdriver wrapped in a shop towel, pry up on the six clips and remove the center console trim. Take care not to damage the clips.

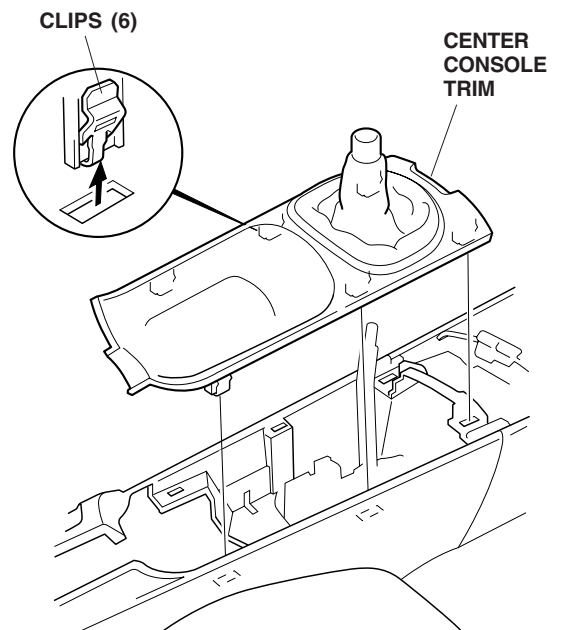

3. Push the boot so it is inside out.

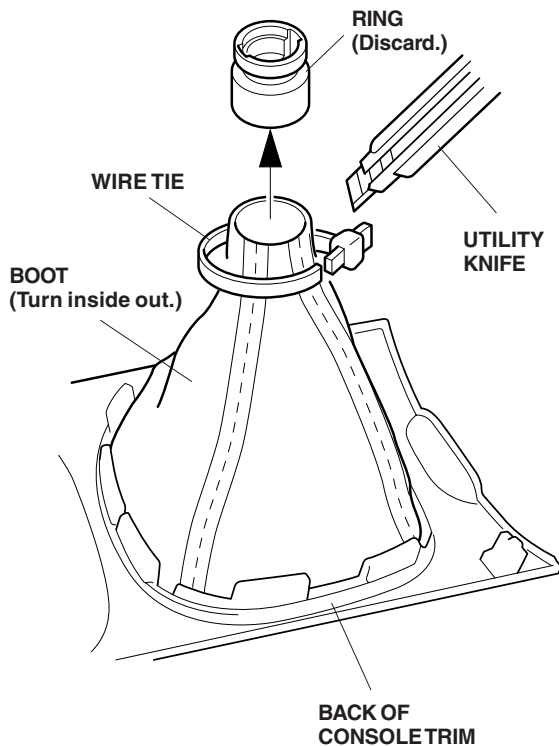

4. Using a utility knife, cut off the wire tie. Take care not to damage the boot when cutting the wire tie.
5. Insert the ring from the kit into the opening of the boot with the wrinkled leather end facing down.

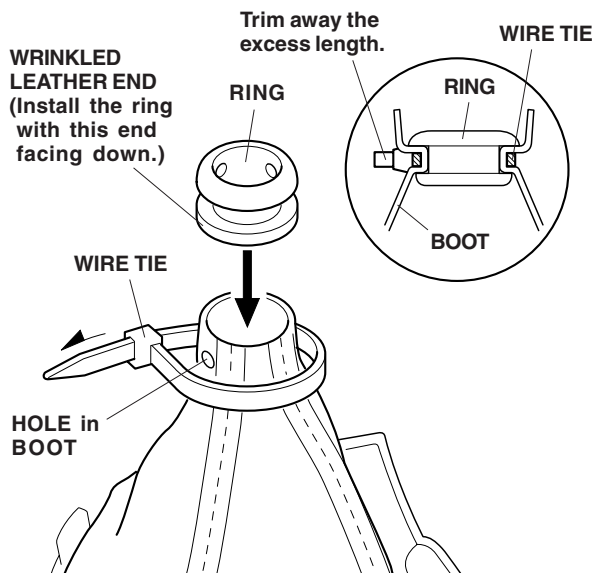

6. Secure the boot to the ring with the wire tie as shown.

7. Turn the boot so it is right side out.
8. Fit the retaining tabs on the collar into the grooves on the ring by squeezing them with your hand. Check that the retaining tabs on the collar are aligned in the ring grooves properly. To prevent damage to the retaining tabs, do not remove the collar once it is installed on the ring.

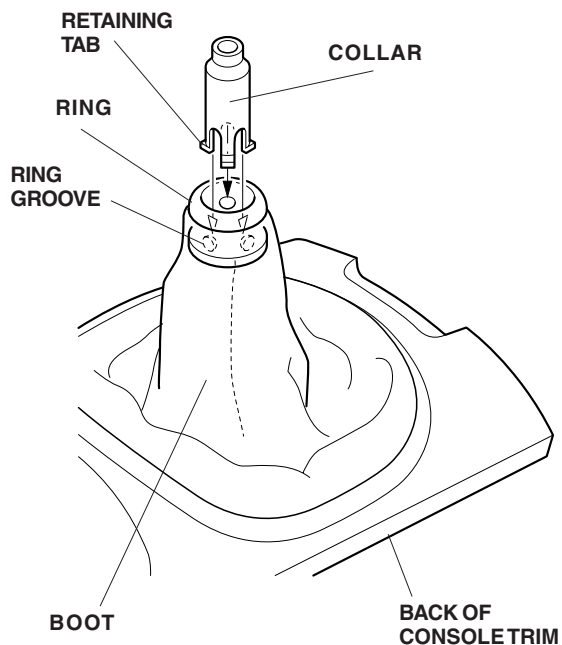

9. Reinstall the console trim.
10. Install the flange nut on the shift lever, flat-side up, to the end of the threads. Note the direction of the flange nut.

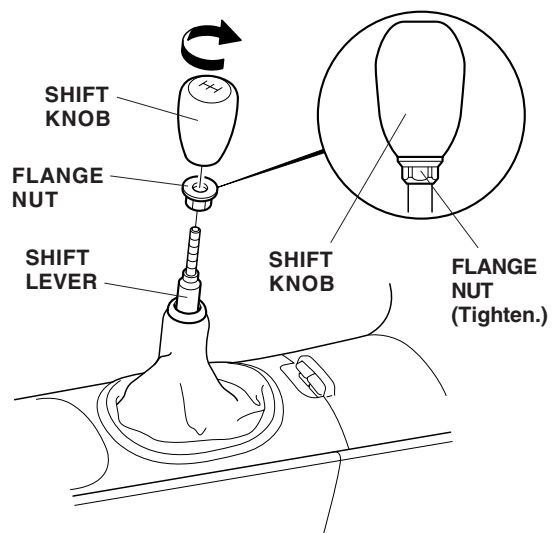

11. Install the shift knob on the shift lever until it is tight, then place it in the correct location, and tighten the flange securely.