



INSTALLATION INSTRUCTIONS

Accessory

KEYLESS ENTRY (HX)
P/N 08E60-S5D-100

Application

2005 CIVIC
2-DOOR

Publications No.

All 27882

Issue Date

AUG 2004

PARTS LIST

2 Transmitters

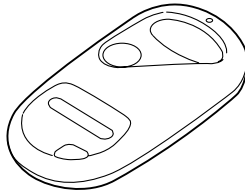

Keyless unit

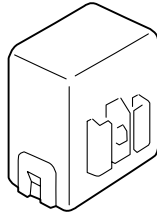

Keyless entry harness

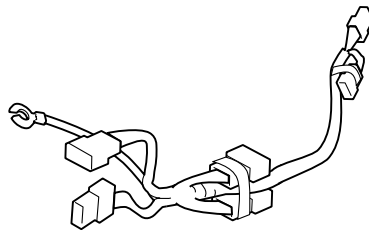

Fuse label

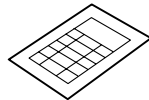

3 Wire ties

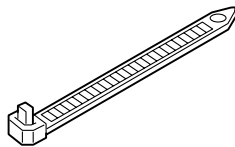

Owner's manual

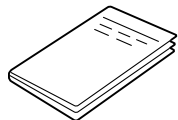

Ground bolt

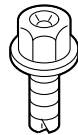

Cushion tape
(Not used)

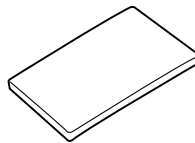

TOOLS AND SUPPLIES REQUIRED

Phillips screwdriver

Flat-tip screwdriver

Ratchet

10 mm Socket

Diagonal cutters

INSTALLATION

Customer Information: The information in this installation instruction is intended for use only by skilled technicians who have the proper tools, equipment, and training to correctly and safely add equipment to your vehicle. These procedures should not be attempted by "do-it-yourselfers."

1. Write down the radio station presets.
2. Disconnect the negative cable from the battery.
3. Remove the dashboard lower cover on the driver's side of the vehicle. Turn the two knobs counterclockwise and release the four retaining tabs.

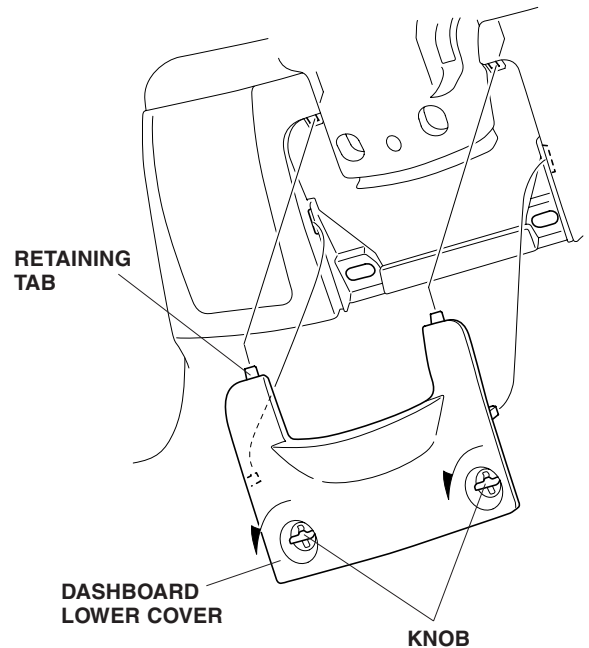

- Remove the driver's dashboard under cover. Turn the knob counterclockwise and, release the two clips and one retaining tab.

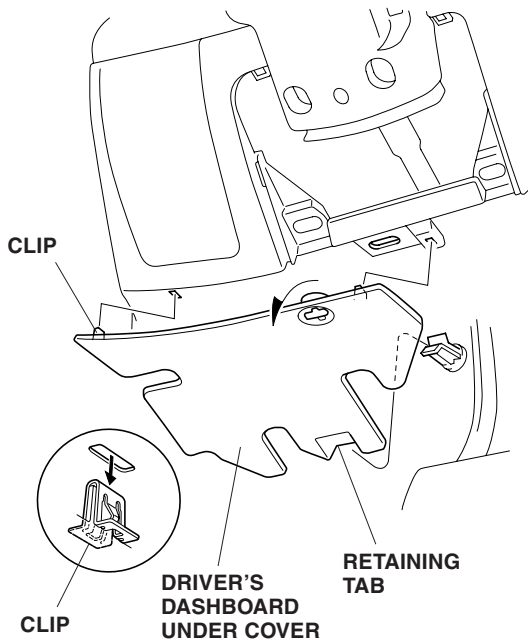

- Pull up on the parking brake lever, then remove the console box (nine clips).

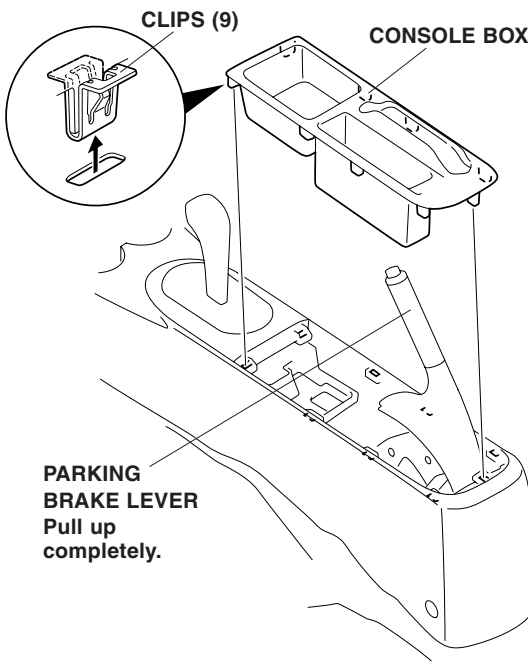

- Remove the center console.

A/T Model:

- Place the shift lever in the Neutral position.
- Remove the two self-tapping screws, two screws and two clips fastening the center console, and remove the console
- If equipped with an optional armrest, adjust the seat-back to the reclining position and remove the console.

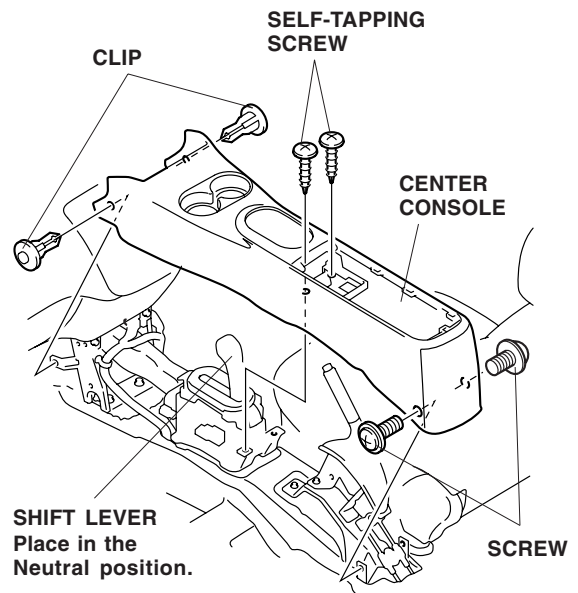

M/T Model:

- Remove the shift knob from the lever by holding the plastic section above the boot down firmly with one hand, and turning the knob in a counterclockwise direction with the other hand.
- Remove the two self-tapping screws, two screws, and two clips that fasten the center console. Remove the console.

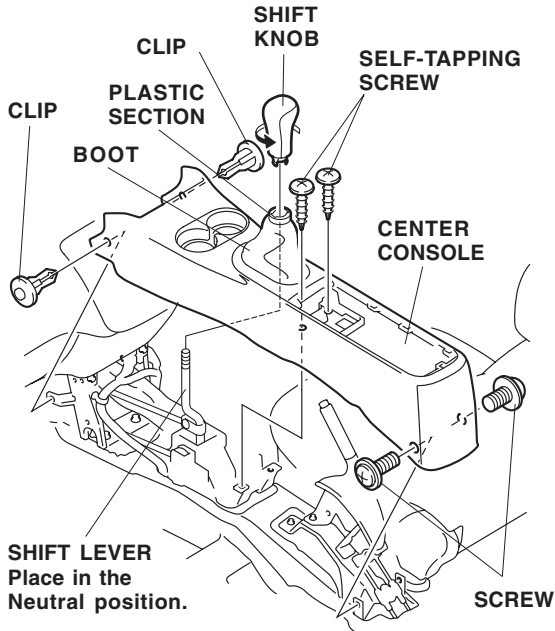

7. Remove the dashboard center lower cover:

- With the parking brake applied, place the gear shift lever in the Neutral position.
- Gently pry out on the lower cover to release the six retaining clips.
- Unplug the accessory socket connector, and remove the lower cover. If equipped, unplug the fog light harness.

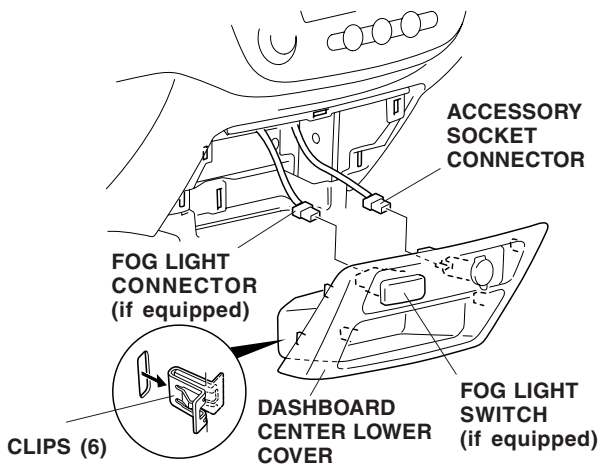

8. Route the keyless entry harness behind the dashboard on the driver's side of the vehicle.

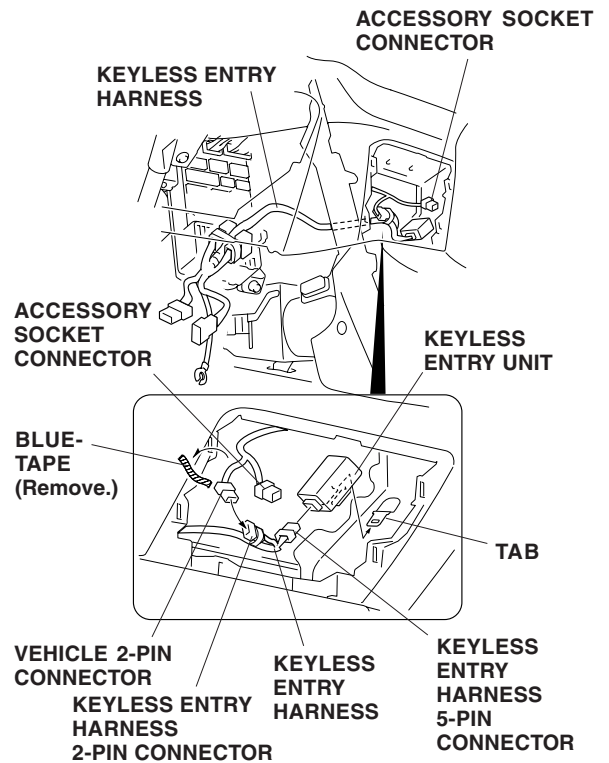

9. Plug the keyless entry harness 5-pin connector into the keyless entry unit, then attach the keyless entry unit to the tab on the center console frame.
10. Locate the 2-pin connector blue-taped to the vehicle accessory socket harness and remove the blue-tape to free the connector. Plug the 2-pin connector into the keyless harness 2-pin connector.

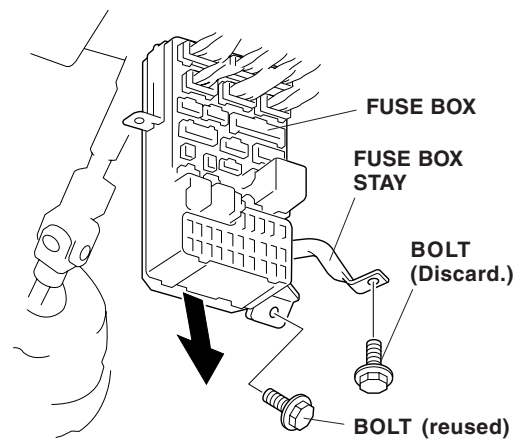

11. Remove the two bolts fastening the fuse box, and the fuse box bracket, then slide the fuse box down.

- Unplug the 10-pin connector from the fuse box, and plug the keyless entry harness 10-pin connector into the fuse box. Plug the vehicle 10-pin connector into the remaining keyless entry harness 10-pin connector.

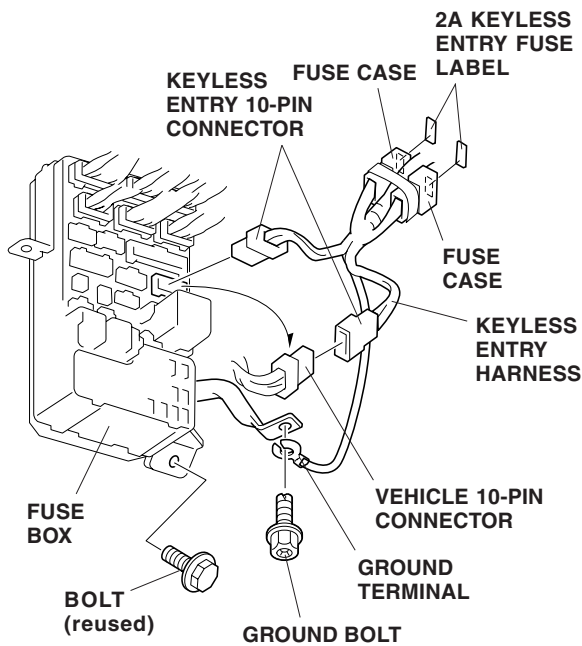

- Attach the two 2A KEYLESS ENTRY fuse labels to the fuse cases on the keyless entry harness.
- Attach the ground terminal of the keyless entry harness to the fuse box bracket with the ground bolt provided.
- Reinstall the fuse box. Be careful not to pinch any harnesses.

- Secure the keyless entry harness to the vehicle harness with three wire ties in the areas shown.

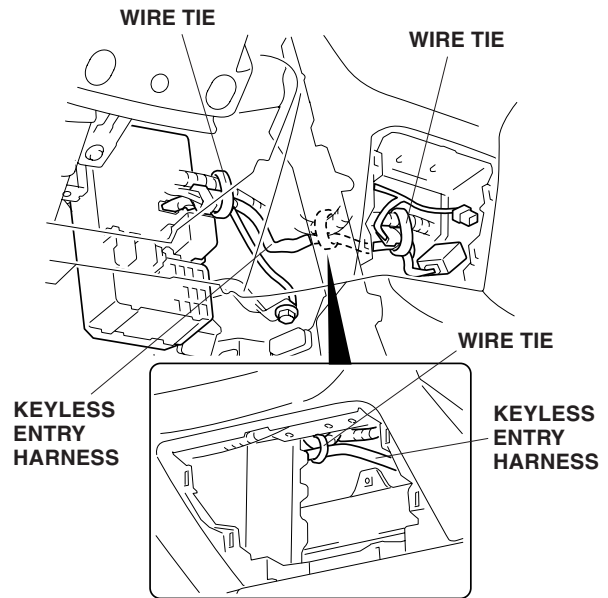

- Check that all wire harnesses are routed properly and all connectors are plugged in.
- Reinstall the all removed the parts.
- Reconnect the negative cable to the battery, and reset the radio station presets.
- Check the operation of the keyless entry system as described in the owner's manual supplied.
NOTE: Whenever the battery is disconnected, the driver's window AUTO function is disabled.
- Start the engine. Push down on the driver's window switch until the window is fully open.
- Pull up on the driver's window switch to close the window completely, then hold the switch for 2 seconds or more.
- Lower and raise the driver's window to check operation of the driver's window AUTO function.
- Do the ECM/PCM idle learn procedure.
 - Make sure all electrical items are turned off.
 - Start the engine. Hold the engine speed at 3,000 rpm with no load (in Park or Neutral) until the radiator fan comes on.
 - Let the engine idle for about 5 minutes with the throttle fully closed and with all electrical items off.

NOTE: If the radiator fan comes on during this step, the time it operates must not be included in the 5 minutes.