



# INSTALLATION INSTRUCTIONS

Accessory  
**6-DISC IN-DASH CD CHANGER/CASSETTE/MP3 PLAYER ATTACHMENT KIT**

Application  
**2004 ELEMENT (DX)**

Publications No.  
**All 26549**  
Issue Date  
**DEC 2003**

## PARTS LIST

**Audio Attachment Kit (sold separately)**  
**P/N 08B06-SCV-100**

BUS cable

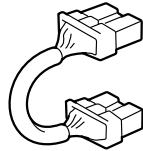

Small harness clip

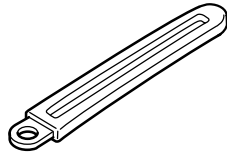

Large harness clip

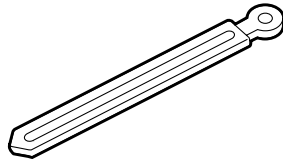

EPT sealer



2 Washer-screws,  
4 x 8 mm

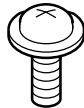

**Cassette Player (sold separately)**  
**P/N 08A03-5E1-000**

Cassette player

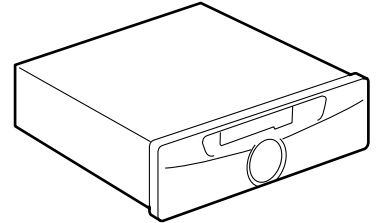

4 Washer-screws, 5 x 8 mm

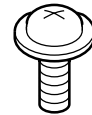

Owner's Manual

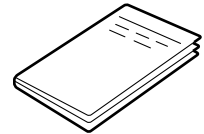

**MP3 Player (sold separately)**  
**P/N 08A06-4E1-200**

MP3 player

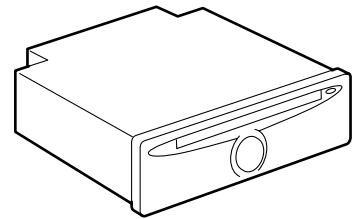

4 Washer-screws, 5 x 8 mm



Owner's Manual

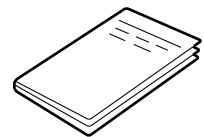

**6-Disc In-Dash CD Changer (sold separately)  
P/N 08A06-3E1-300**

In-Dash CD changer

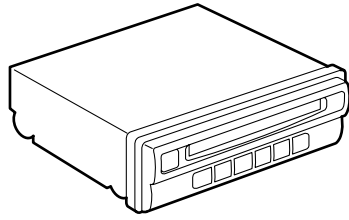

6 Washer-screws, 5 x 8 mm  
(2 not used)



Washer-screw, 4 x 6 mm



Wire tie  
(not used)

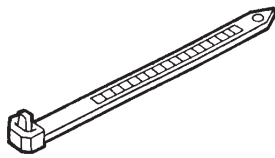

Harness clip  
(not used)

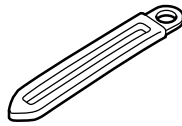

Owner's Manual

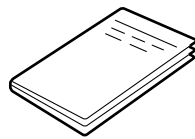

**TOOLS AND SUPPLIES REQUIRED**

- Phillips screwdriver
- Flat-tip screwdriver
- 10 mm combination wrench
- Isopropyl alcohol
- Shop towel
- Ratchet
- 8 mm socket
- Scissors

**INSTALLATION**

**Customer Information:** The information in this installation instruction is intended for use only by skilled technicians who have the proper tools, equipment, and training to correctly and safely add equipment to your vehicle. These procedures should not be attempted by "do-it-yourselfers."

1. Wrap a shop towel around the top of a flat-tip screwdriver and insert it into the grooves of the audio panel. Pull the audio panel out toward you to release the five clips, and remove the audio panel. Take care not to damage the clips and the audio panel.

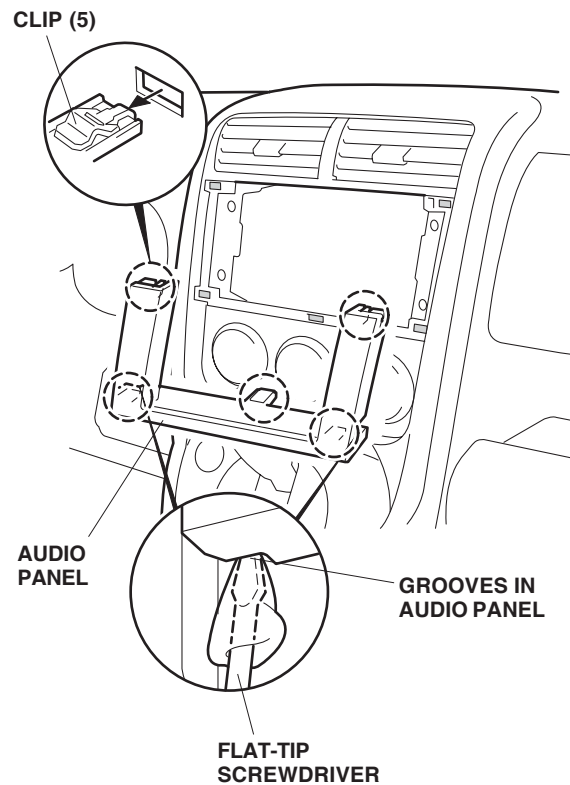

- Remove the four self-tapping screws that fasten the audio unit, and pull the unit out toward you. Unplug the vehicle connector and the antenna lead from the back of the AM/FM CD tuner, and remove the audio unit from the instrument panel.

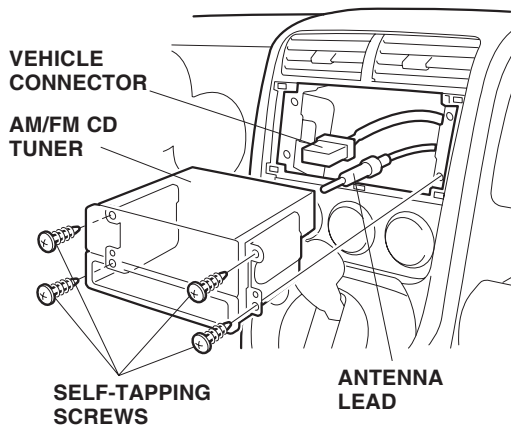

- Remove the four washer-screws and two self-tapping screws that fasten the bracket "L" and bracket "R" to the AM/FM CD tuner and pocket. Save the pocket and screws for your customer.

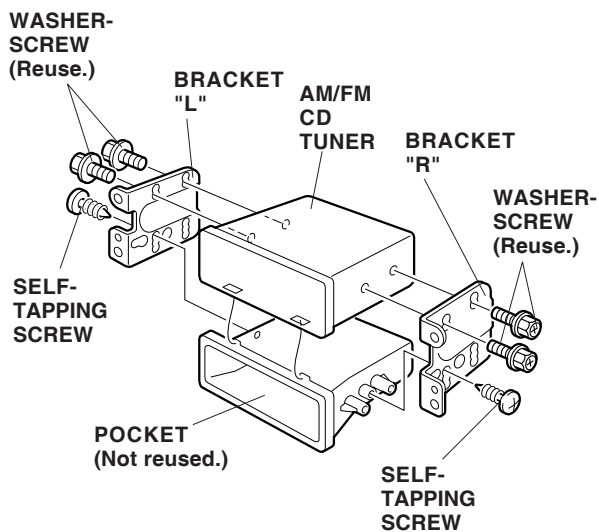

## Installing the Player

- Position the bracket "L" and the bracket "R" on the AM/FM CD tuner and player, and install the four 5 x 8 mm washer-screws from the kit and four screws you just removed.

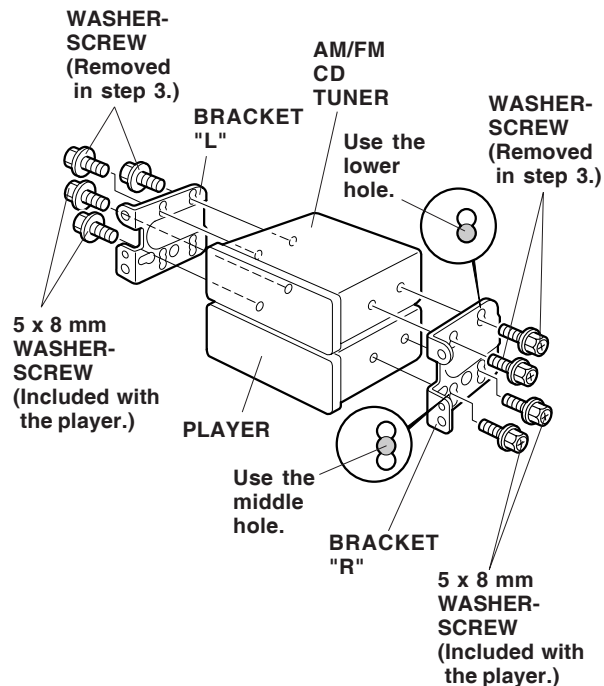

5. Plug the BUS cable connectors into the rear of the AM/FM CD tuner and player, then secure the BUS cable with the harness clip as shown.

### Cassette Player

- Plug the BUS cable connectors into the rear of the AM/FM CD tuner and cassette player.
- Secure the small harness clip to the back of the cassette player with the 4 x 8 mm washer-screw.

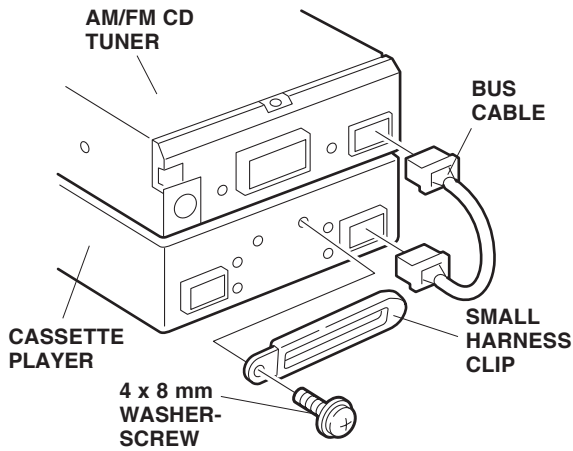

- Secure the BUS cable with the small harness clip.

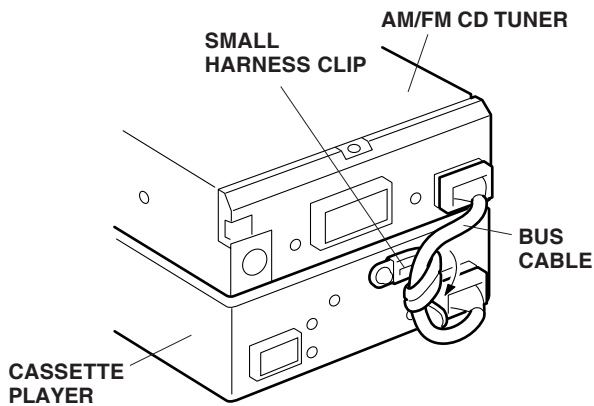

### MP3 Player

- Plug the BUS cable connectors into the rear of the AM/FM CD tuner and MP3 player.
- Secure the small harness clip to the back of the MP3 player with the 4 x 8 mm washer-screw.

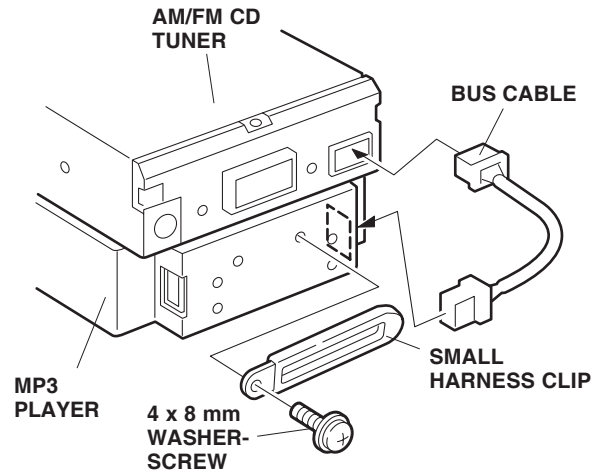

- Secure the BUS cable with the small harness clip.

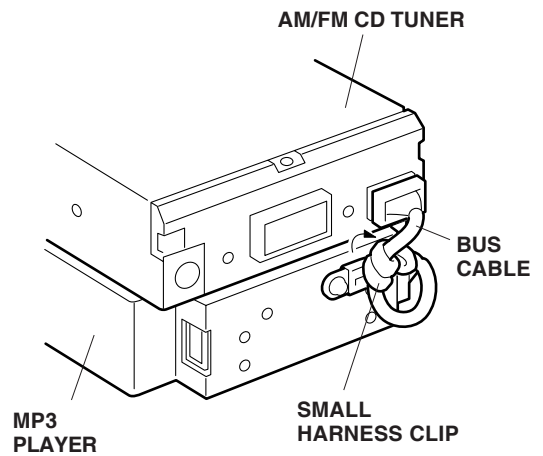

## In-Dash CD Changer

- Plug one BUS cable connector into the rear of the AM/FM CD tuner and the other into the connector from the in-Dash CD changer.
- Secure the large harness clip to the rear of the in-dash CD changer with the 4 x 6 mm washer-screw included with the in-dash CD changer.

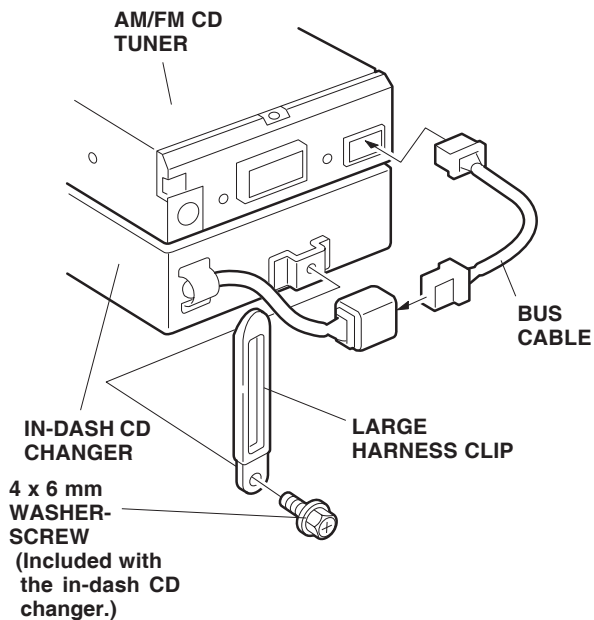

- Secure the BUS cable connectors to the in-dash CD changer with the large harness clip. Get the EPT sealer from the attachment kit. Wrap the EPT sealer around the screw head in the area shown.

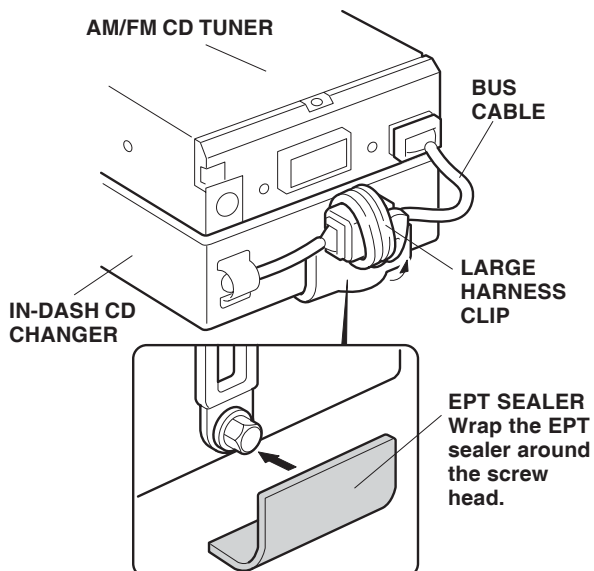

6. Plug in the vehicle connector and the antenna lead in to back of the AM/FM CD tuner, then reinstall the audio unit using four screws.

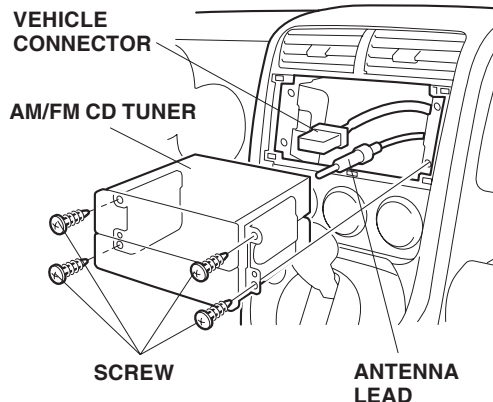

7. Enter the customer's radio anti-theft code and reset the radio station presets.
8. Reset the clock.
9. Check the operation of the in-dash CD changer/ cassette player/ MP3 player according to the Owner's Manual provided.
10. Reinstall all removed parts.
11. Put the in-dash CD changer/cassette player/ MP3 player Owner's Manual in the glove box.