



INSTALLATION INSTRUCTIONS

Accessory
SIDE STEP
 P/N 08L33-S9A-100A

Application
2004 CR-V

Publications No.
All 26141

Issue Date
SEP 2003

PARTS LIST

Left side step

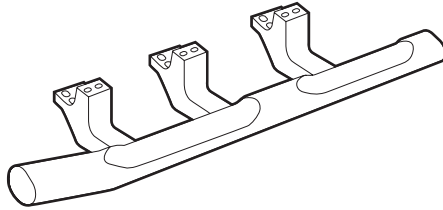

Right side step

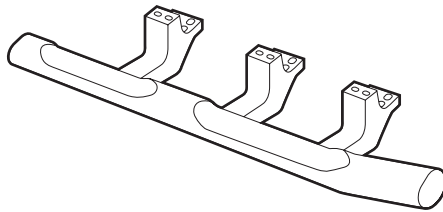

5 Brackets

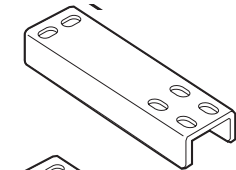

Long bracket (left side only)

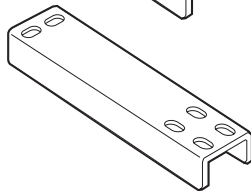

48 Flange bolts



24 Flange nuts



Jack Label

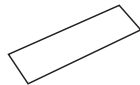

Owner's Manual page

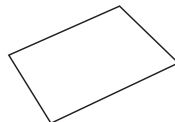

TOOLS REQUIRED

- Ratchet
- 13 mm Socket
- 13 mm Combination wrench
- Torque wrench
- Extension

INSTALLATION

Customer Information: The information in this installation instruction is intended for use only by skilled technicians who have the proper tools, equipment, and training to correctly and safely add equipment to your vehicle. These procedures should not be attempted by "do-it-yourselfers."

- Loosely position the three brackets (long bracket on the left side) on the left side step; install the four flange bolts and four flange nuts on each one. Do not tighten the bolts yet.

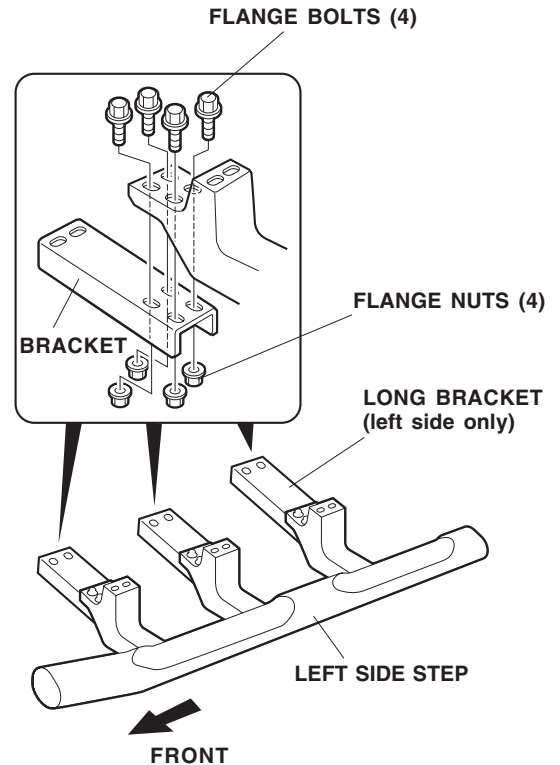

- Position the left side step on the body and loosely install the twelve flange bolts.

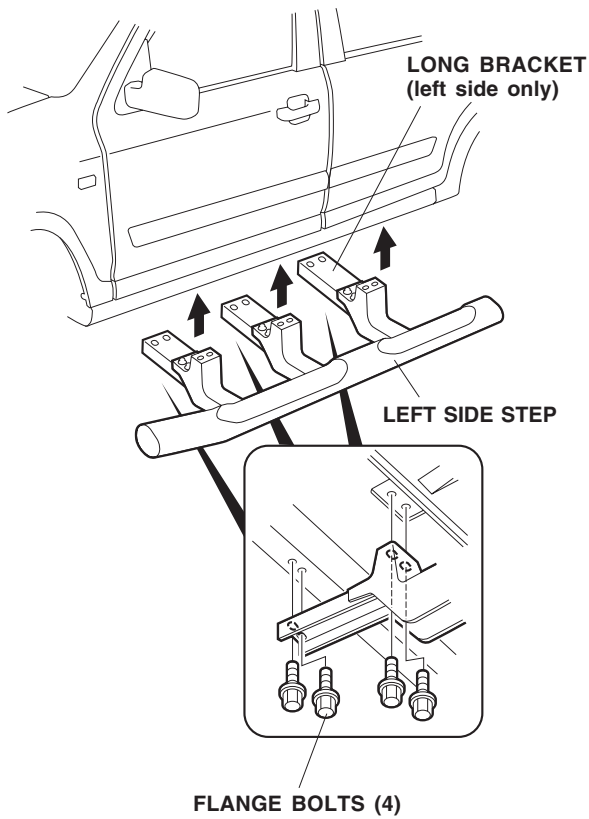

- Torque all the flange nuts and bolts to 23 N-m (17 lb-ft).
- Repeat steps 1 through 3 to install the side step on the right side of the vehicle. The brackets on the right side are all one length.

Installing the Jack Label

- Remove the jack from the cargo area. Refer to the vehicle Owner's Manual in the glove box.

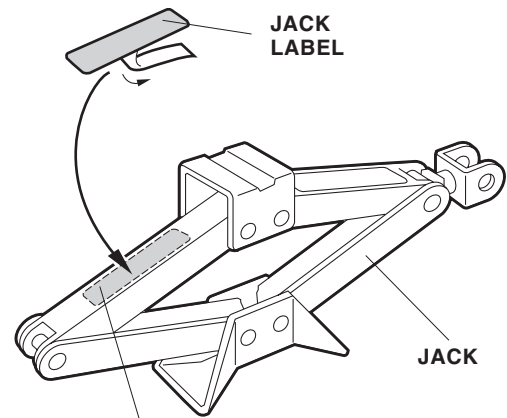

Using isopropyl alcohol, thoroughly clean the area where the caution label will attach.

- Using isopropyl alcohol, thoroughly clean the area where the caution label will attach.
- Remove the adhesive backing from the jack label, and attach it to the jack, as shown. Reinstall the jack in the cargo area.
- Insert the owner's manual page from this kit into the vehicle Owner's Manual, and put it in the glove box.