



INSTALLATION INSTRUCTIONS

Accessory
CD CHANGER ATTACHMENT KIT

Application
2004 CR-V

Publications No.
All 26118
Issue Date
SEP 2003

PARTS LIST

**CD Changer Attachment Kit (sold separately):
P/N 08B26-S9A-100**

Right base bracket

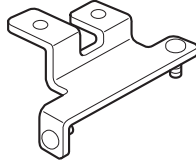

Left base bracket

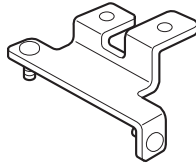

Right side bracket

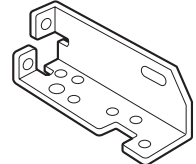

Left side bracket

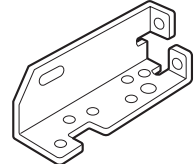

BUS cable

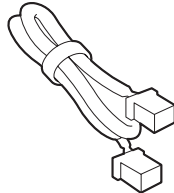

4 Washer-bolts, 6 x 16 mm



4 Washer-screws, 4 x 8 mm



4 Flange nuts, 6 mm



3 EPT sealers

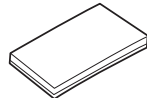

10 Wire ties

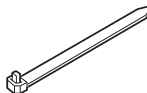

Wire tie with clip

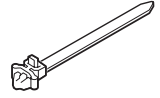

3 Cushion tapes

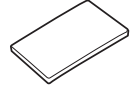

**CD Changer (sold separately):
P/N 08A06-1B1-420**

CD Changer unit

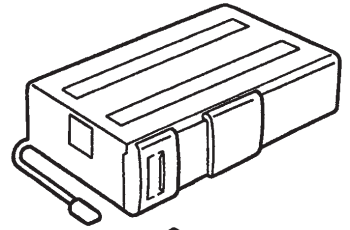

Owner's Manual



CD magazine

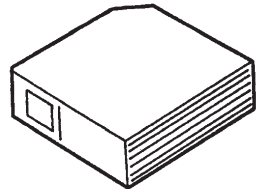

8 Washer-screws, 4 x 6 mm



Adhesive seal sheet

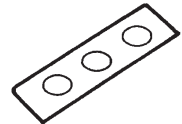

Locking covers

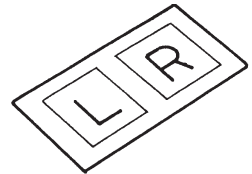

TOOLS AND SUPPLIES REQUIRED

Phillips screwdriver
Flat-tip screwdriver
14 mm Combination wrench
Masking tape
Tape measure
Diagonal cutters
Ratchet
19 mm Socket
Shop towel
Scissors
Isopropyl alcohol

Illustration of the CD Changer Installed on the Vehicle

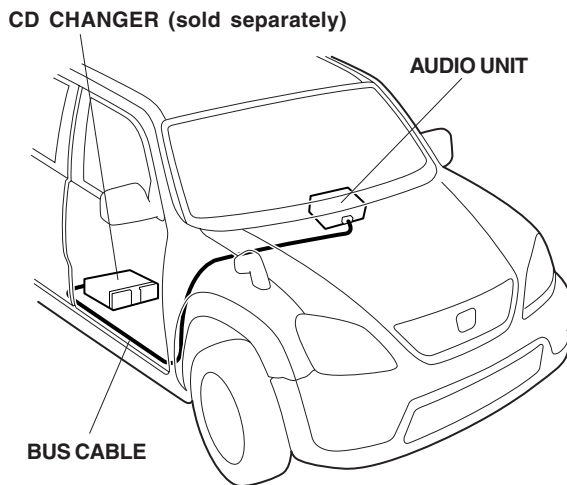

INSTALLATION

Customer Information: The information in this installation instruction is intended for use only by skilled technicians who have the proper tools, equipment, and training to correctly and safely add equipment to your vehicle. These procedures should not be attempted by “do-it-yourselfers.”

1. Make sure you have the anti-theft code for the radio, then write down the radio station presets.
2. Disconnect the negative cable from the battery.

3. Remove the two self-tapping screws that fasten the bottom of the center panel.

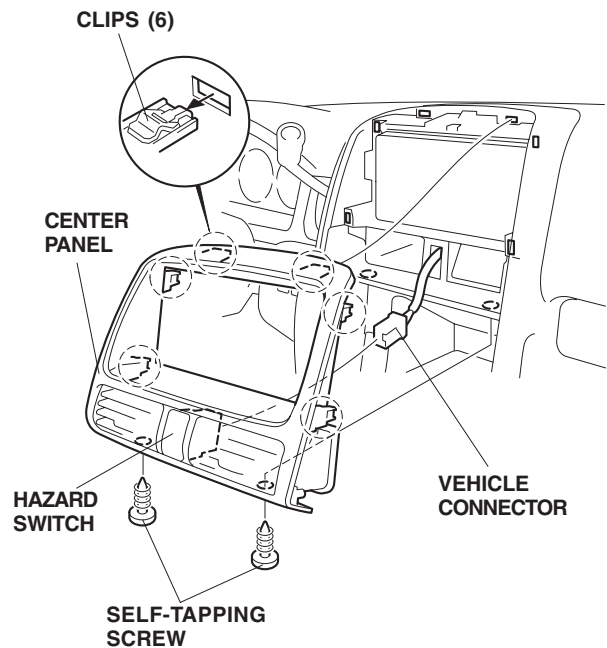

4. Pull the center panel out toward you to release the six clips, unplug the vehicle connector from the hazard switch, and remove the center panel. Take care not to damage the clips.
5. Remove the four screws that fasten the audio unit to the dashboard. Remove the audio unit by pulling it out toward you and unplugging the vehicle connector and the antenna lead.

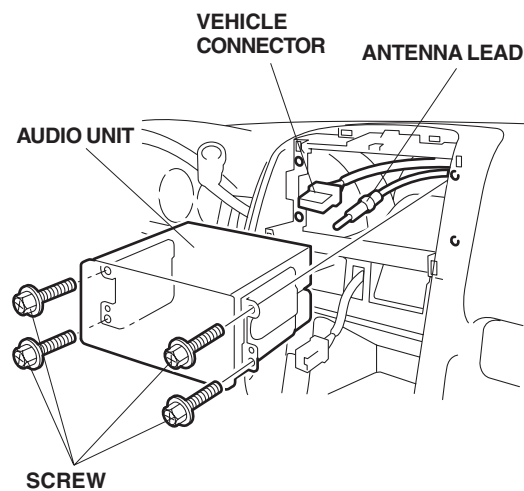

- Remove the passenger's dashboard under cover (release the three clips and two pins).

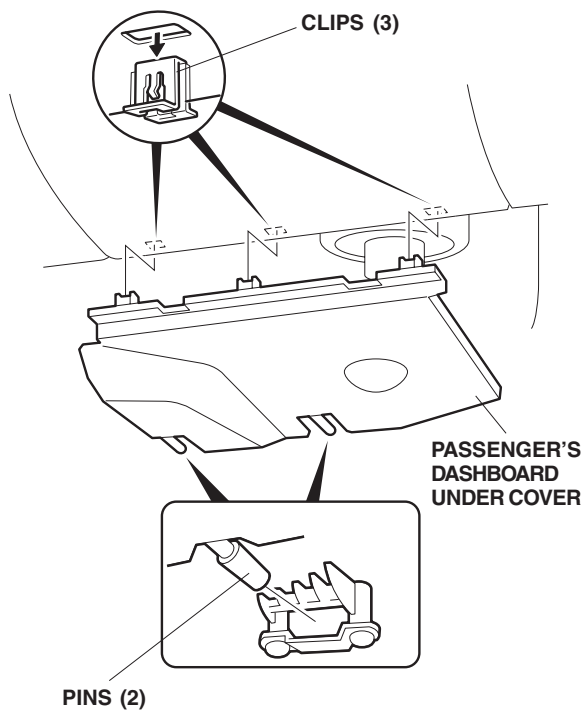

- Open the glove box. Release the right and left stops. Release the two tabs.

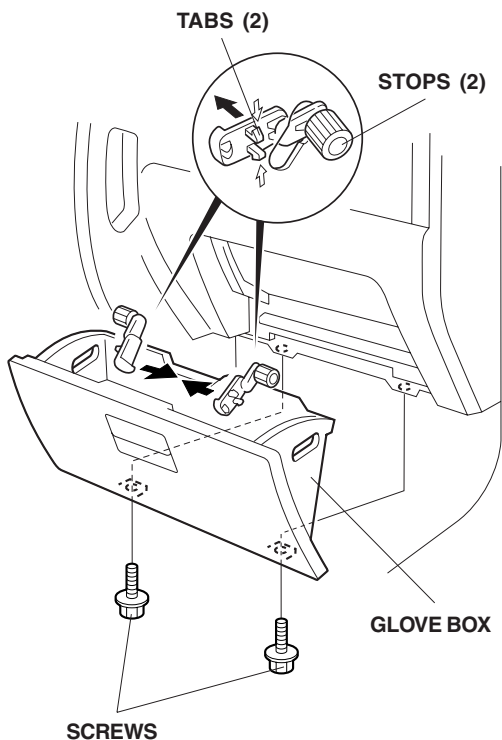

- Remove the two screws from the bottom of the glove box, and remove the glove box.

- Remove the three seat track end covers from the passenger's seat, then remove the four bolts that secure the seat.

M/T VEHICLE:

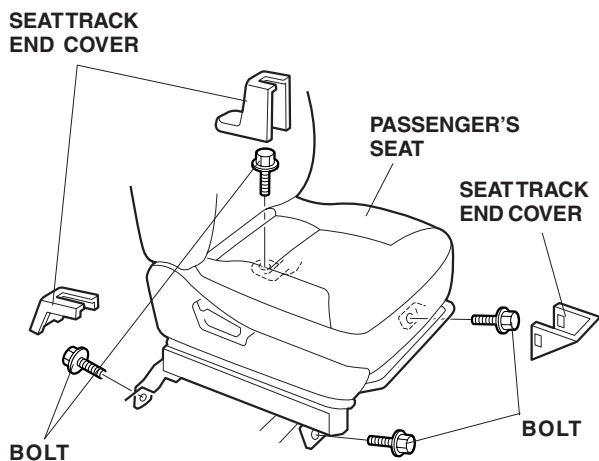

A/T VEHICLE:

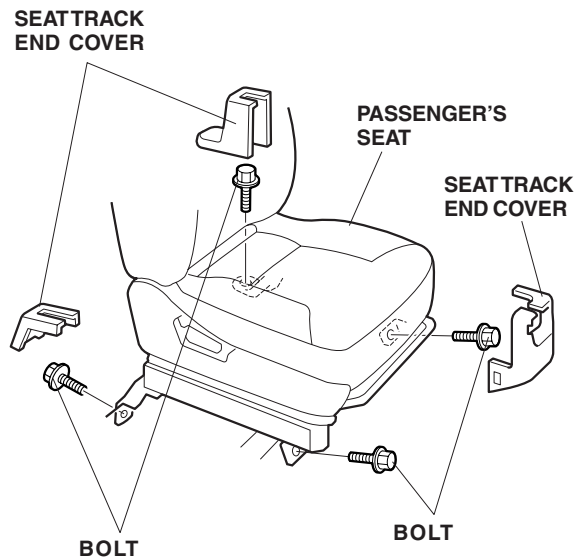

- Remove the right kick panel by pulling it out toward you to release the two clips and then pull back to release the five tabs. Take care not to damage the clips.

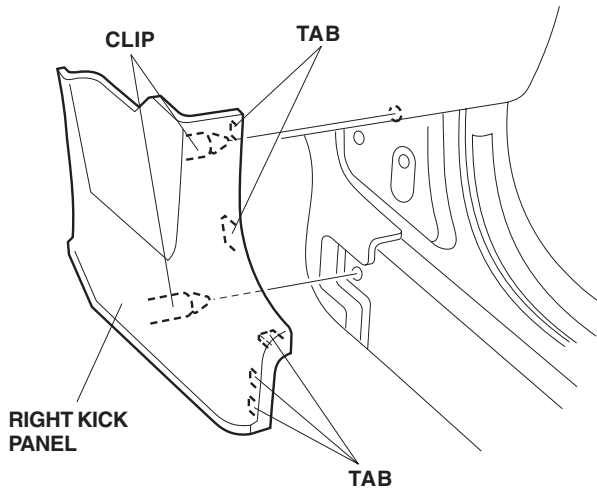

- Gently slide the front passenger's seat toward the center of the vehicle. Be careful not to apply tension to the yellow SRS harness.

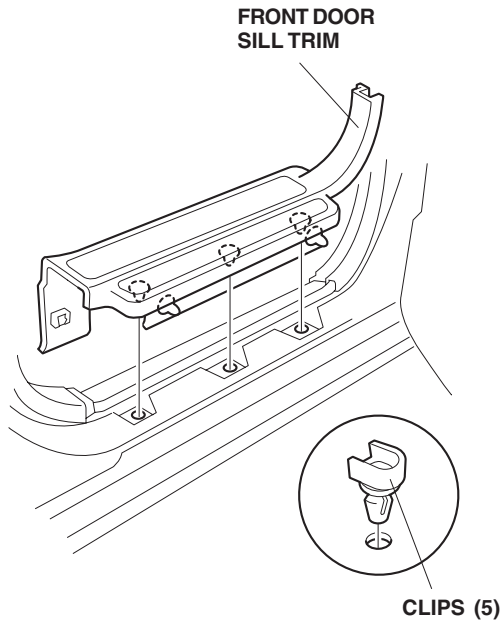

- Reach inside the vehicle, and pull out on the bottom of the right-front door sill trim to release the two clips; then, lift the trim up to release the three clips, and remove the trim.

- Tilt the front passenger's seat back.

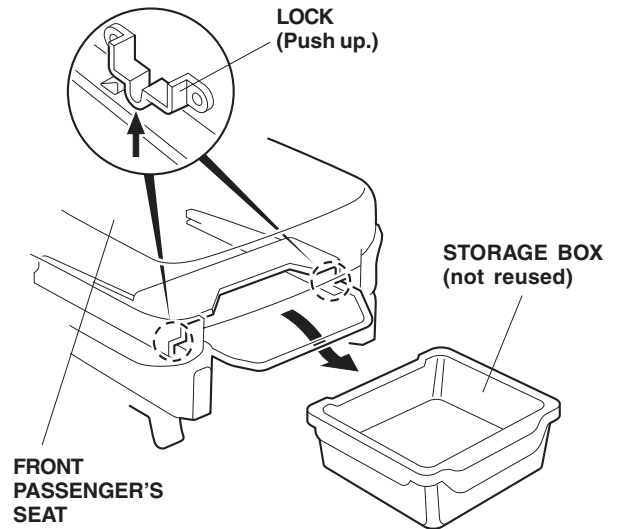

- Push up on the locks, and slide out the storage box.
- Remove the under seat tray rail (four screws). Set the storage box and rail aside; they will not be needed.

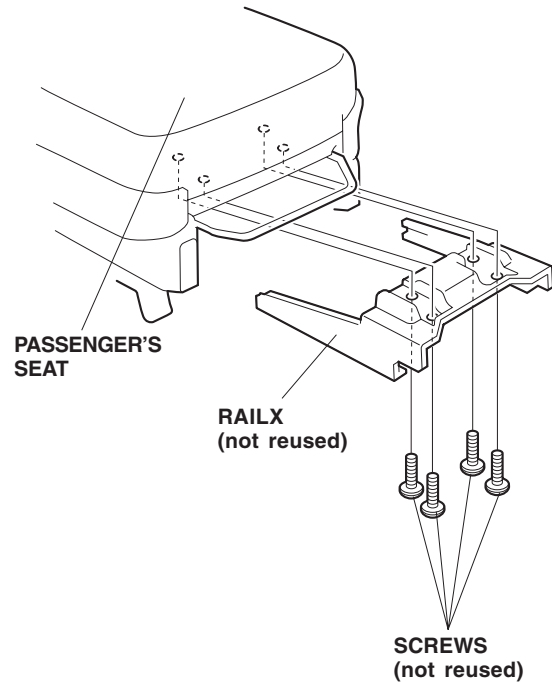

Routing the BUS Cable

16. From the glove box area, route the BUS cable through the center panel opening. Align the BUS cable 14-pin connector with the vehicle 20-pin connector.

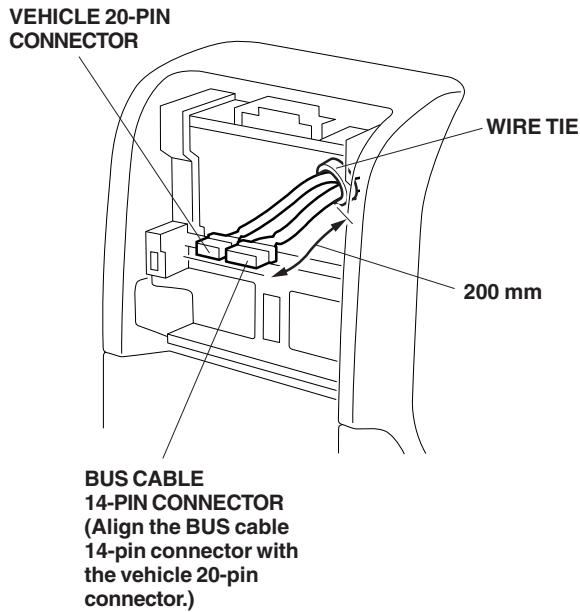

17. Secure the BUS cable to the vehicle harness with one wire tie 200 mm away from the connector ends.
18. Route the BUS cable to the glove box opening, and secure it to the vehicle harness and the vehicle frame pipe with the eight wire ties in the areas shown.

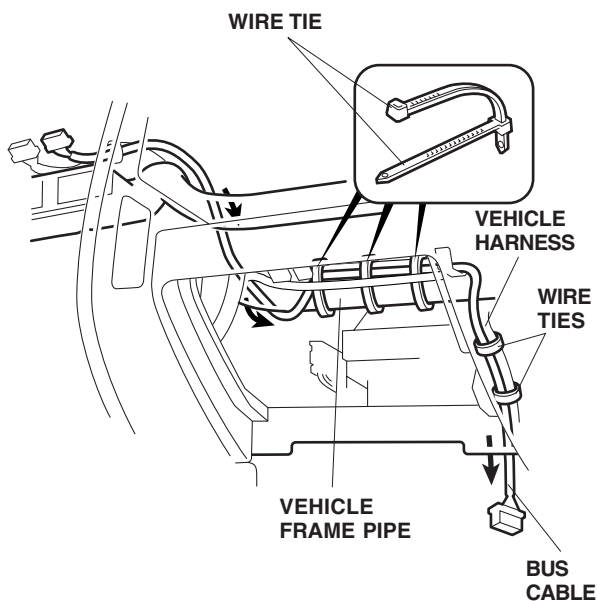

19. Under the front passenger's seat, measure and mark the carpet as shown. Using a utility knife, make a cut in the carpet as indicated by the mark. Be careful not to damage the wire harnesses routed under the floor carpet.

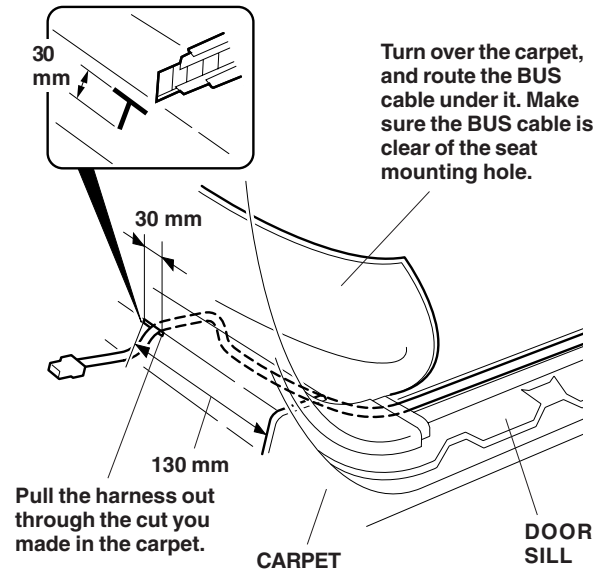

20. Route the BUS cable along the door sill, and along the cross member, then pull the harness out through the cut you made in the carpet.
21. Use isopropyl alcohol to clean the areas where the cushion tapes will attach. Secure the BUS cable to the side of the door sill with three cushion tapes.

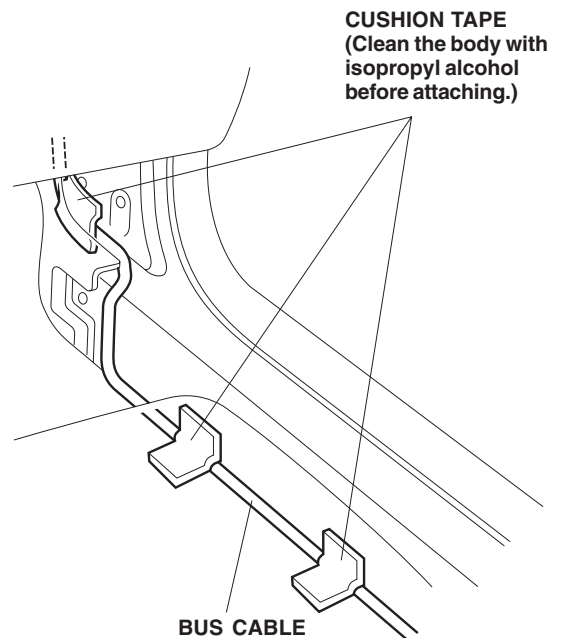

Installing the CD Changer

22. Carefully unpack the CD changer. Remove the three shipping clips, and install a seal (included with the CD changer) over each of the three clip holes. Save the clips for your customer in case the unit needs to be serviced.

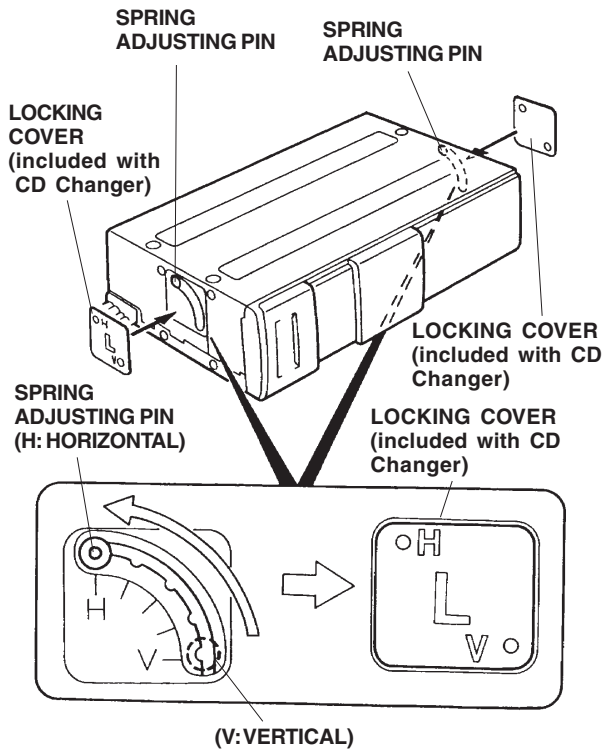

23. Visually check the location of the spring adjusting pins on both sides through the holes in the covers. If the spring adjusting pins are not in the horizontal (H) position, adjust them.
24. Move the pins to the HORIZONTAL position by sliding them with an awl or a screwdriver.
25. Attach the two labels (included with the CD changer) to the sides of the CD changer.

26. Position the right and left side brackets on the CD changer, and install the two 4 x 8 mm washer-screws for each bracket. Install the screws in the holes marked "B."

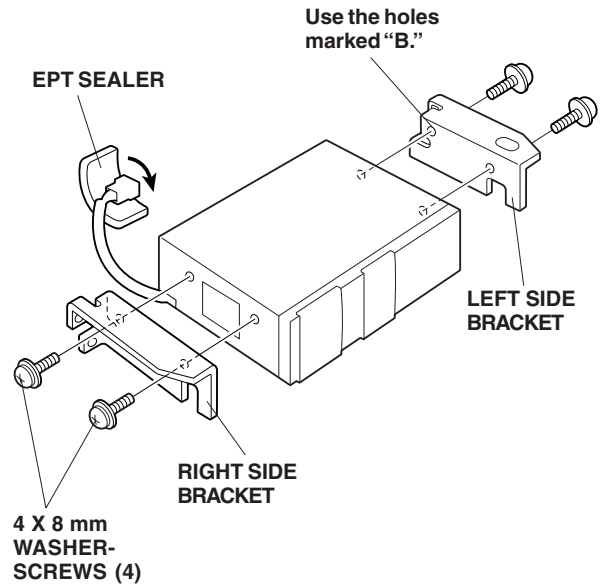

27. Wrap an EPT sealer around the BUS cable connector from the CD changer as shown.
28. Position the right and left base brackets on the seat panel under the right seat, and install the four 6 mm washer-bolts.

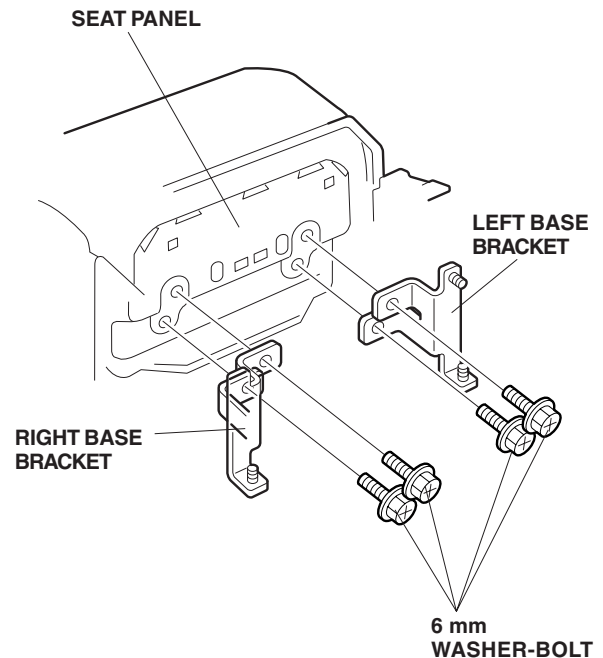

- Insert the studs of the base brackets into the holes in the right and left side brackets. Install a 6 mm flange nut on the end of each stud.

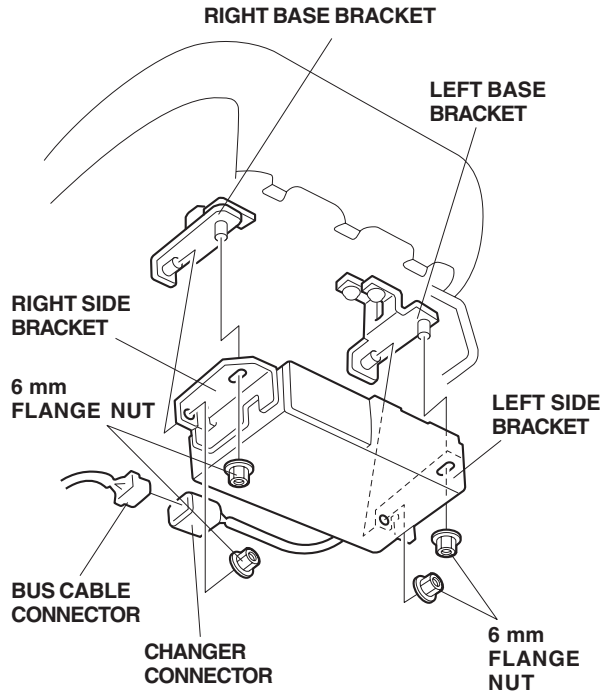

- Plug the BUS cable connector into the CD changer connector.
- Secure the BUS cable to the right side bracket with the wire tie with clip.

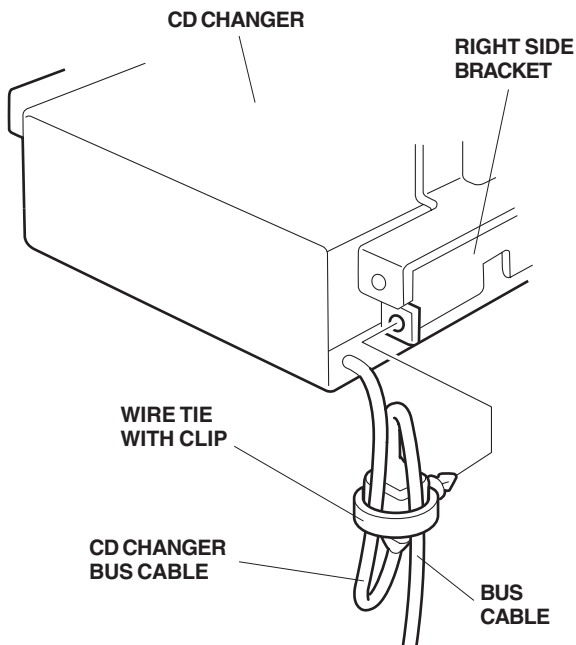

- Reinstall the front passenger's seat. Torque the seat bolts to 32 to 37 N·m (23 to 27 lb-ft).
- Slide the front passenger's seat back and forth to check that the BUS cable is not too tight or too loose.

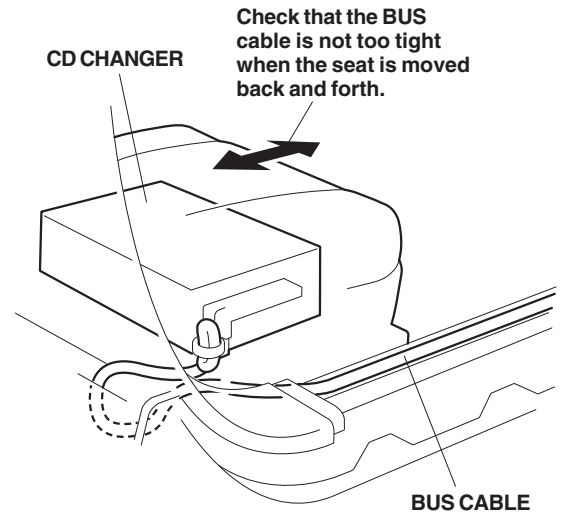

- Plug the BUS cable 14-pin connector, the vehicle 20-pin connector, and antenna lead into the rear of the audio unit.

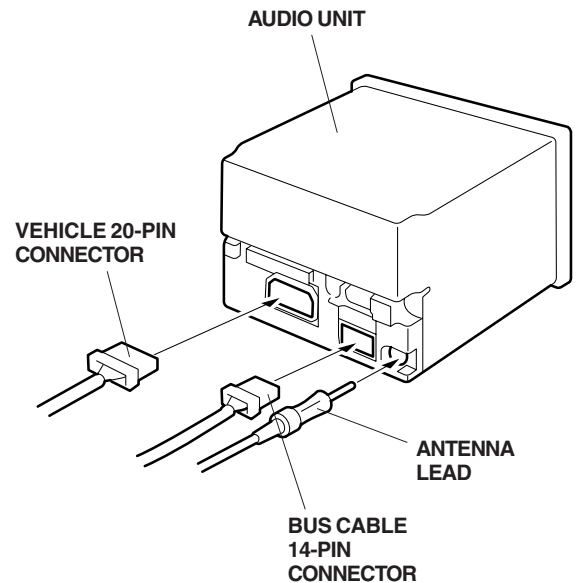

35. Slide the audio unit into the radio opening in the instrument panel, and reinstall the four screws.

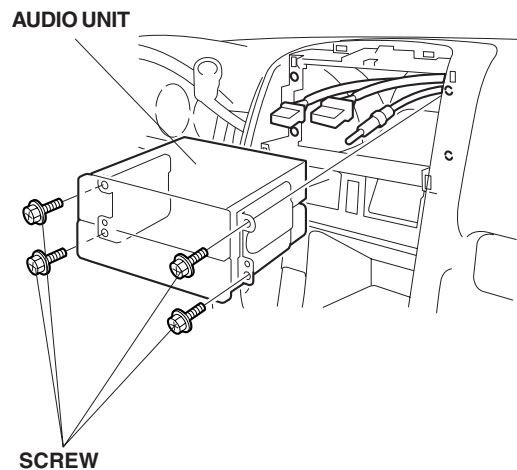

36. Check that all wire harnesses are routed properly and all connectors are plugged in.
37. Reinstall all removed parts.
38. Reconnect the negative cable to the battery.
39. Enter the customer's radio anti-theft code, and reset the radio station presets.

NOTE: Whenever the battery is disconnected, the driver's window AUTO function is disabled.

40. Start the engine. Push down on the driver's window switch until the window is fully open.
41. Pull up on the driver's window switch to close the window completely, then hold the switch for 2 seconds or more.
42. Test the AUTO window function.
43. Do the ECM/PCM idle learn procedure.
 - Make sure all electrical items are turned off.
 - Start the engine. Hold the engine speed at 3,000 rpm with no load (in Park or Neutral) until the radiator fan comes on.
 - Let the engine idle for about 5 minutes with the throttle fully closed and with all electrical items off.

NOTE: If the radiator fan comes on during this step, the time it operates must not be included in the 5 minutes.