



INSTALLATION INSTRUCTIONS

Accessory	Application	Publications No.
KEYLESS ENTRY SYSTEM	2003 PILOT	All 23619
		Issue Date
		MAY 2002

PARTS LIST

Keyless Entry Kit (sold separately):
P/N 08E61-S84-100

2 Remote controls

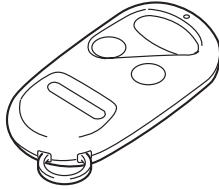

Control unit

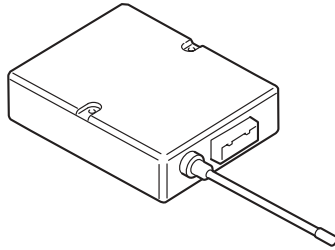

Owner's Manual

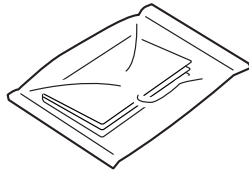

2 Washer-screws, 4 x 30 mm

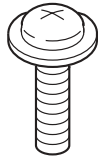

Attachment Kit (sold separately):
P/N 08E65-S9V-100

Keyless entry harness

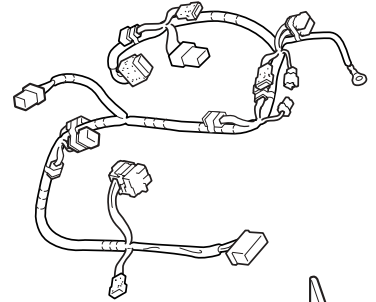

Unit bracket

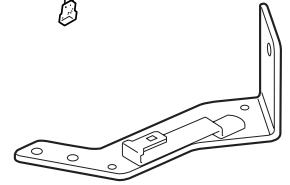

2 Flange nuts



8 Wire ties

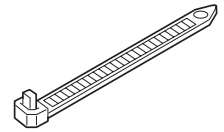

Relay

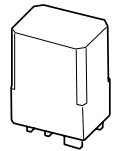

Fuse label

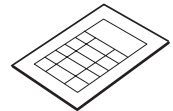

2 Wire ties with clip

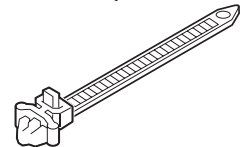

2 Cushion tapes

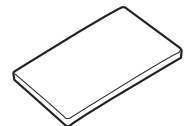

Ground bolt

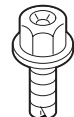

TOOLS AND SUPPLIES REQUIRED

Phillips screwdriver
Flat-tip screwdriver
8 mm and 10 mm Combination wrenches
Ratchet
10 mm and 12 mm Sockets
Torque wrench
Diagonal cutters
Isopropyl alcohol
Shop towel
Scissors

Illustration of Keyless Entry Installed on the Vehicle

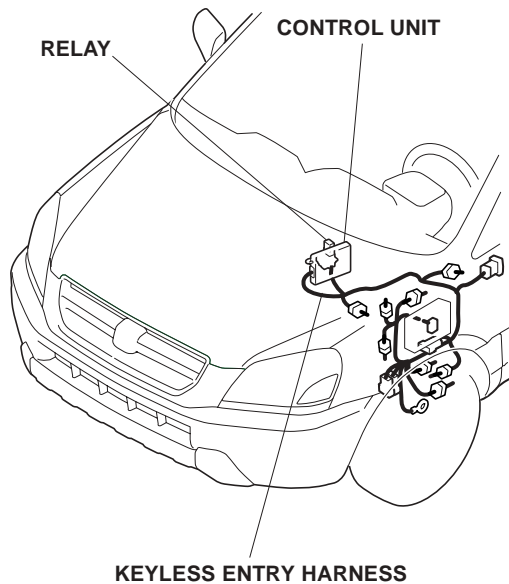

INSTALLATION

Customer Information: The information in this installation instruction is intended for use only by skilled technicians who have the proper tools, equipment, and training to correctly and safely add equipment to your vehicle. These procedures should not be attempted by “do-it-yourselfers.”

1. Make sure you have the anti-theft code for the radio, then write down the frequencies for the preset buttons.
2. Disconnect the negative cable from the battery.
3. Remove the driver's dashboard lower cover (one self-tapping screw, three clips, and two hooks).

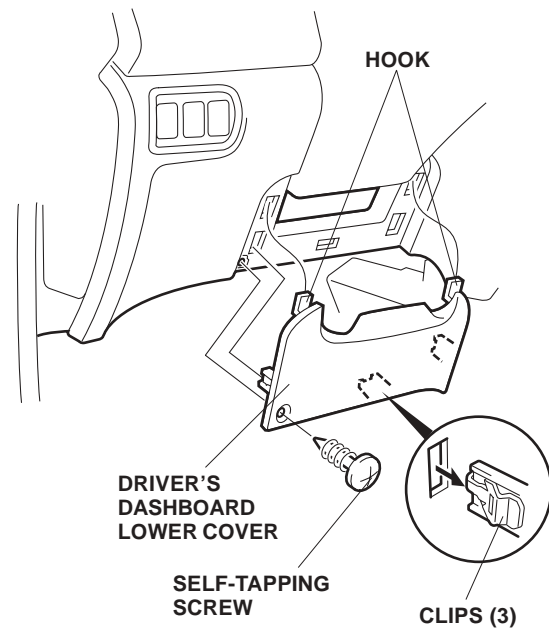

- Remove the switch trim (two clips and two retaining tabs), then unplug the interior light harness connector from the switch.

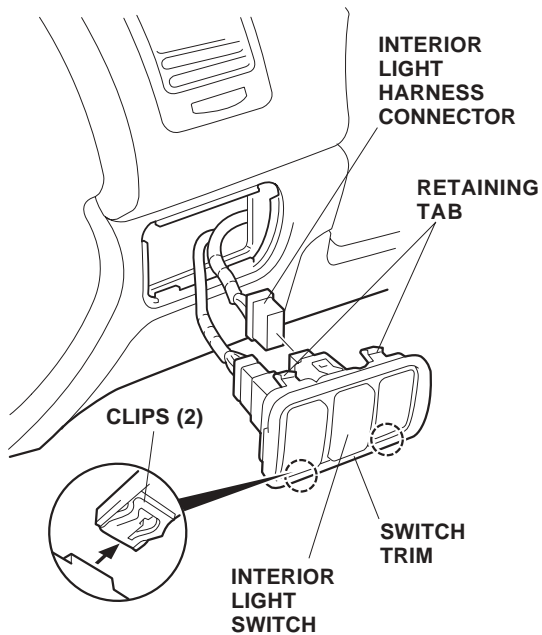

- Remove the fuel lid opener knob, then remove the left front trim (three clips and two retaining tabs).

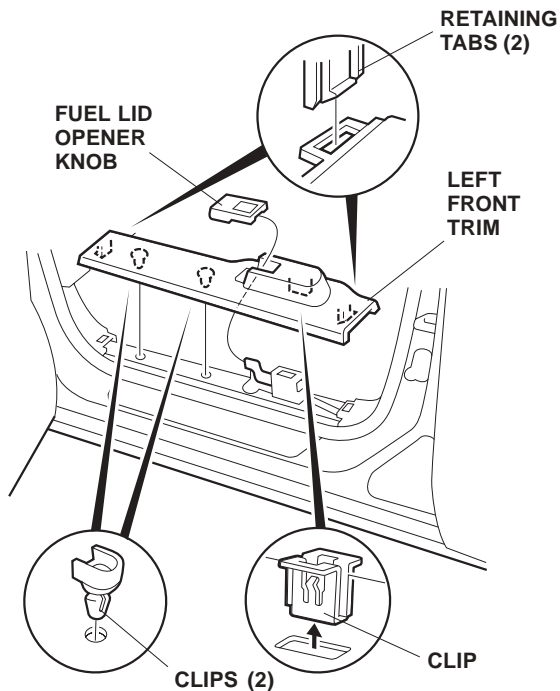

- Remove the weatherstrip from the left kick panel.

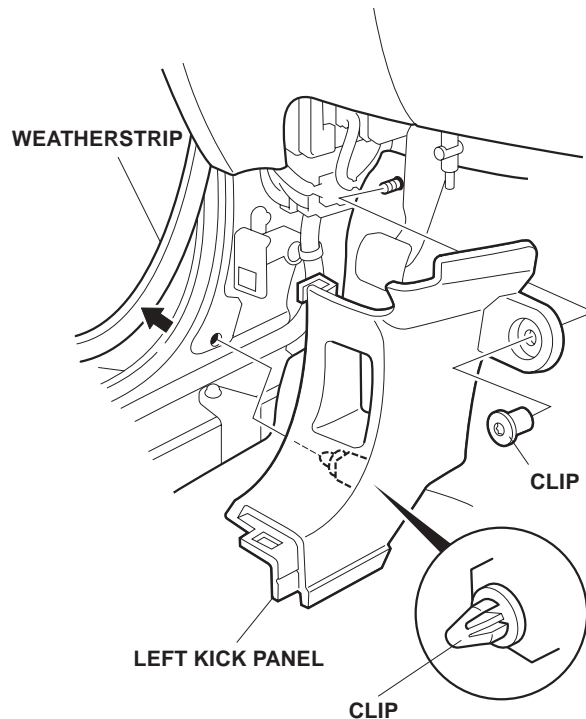

- Remove the upper clip from the left kick panel, then pull the left kick panel out toward you to release the remaining clip.
- Position the unit bracket on the control unit, and install the two 4 x 30 mm washer-screws and two flange nuts.

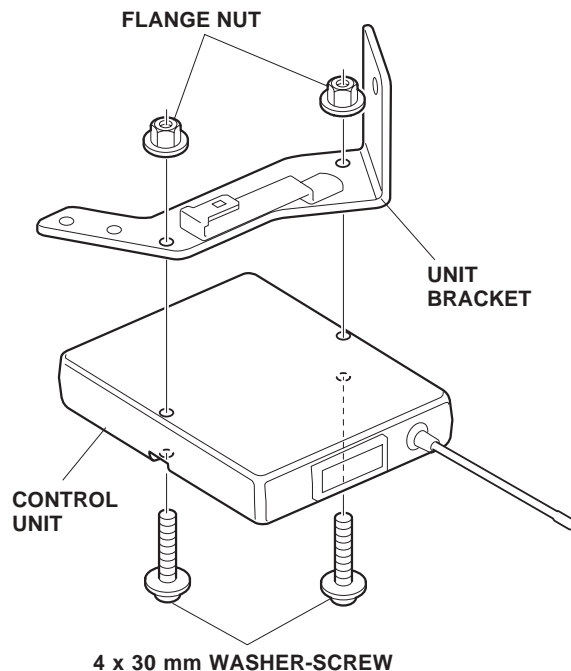

- Wrap the cushion tape around the antenna of the control unit, then pull the antenna out through the clearance between the unit bracket and the stay on the unit bracket.

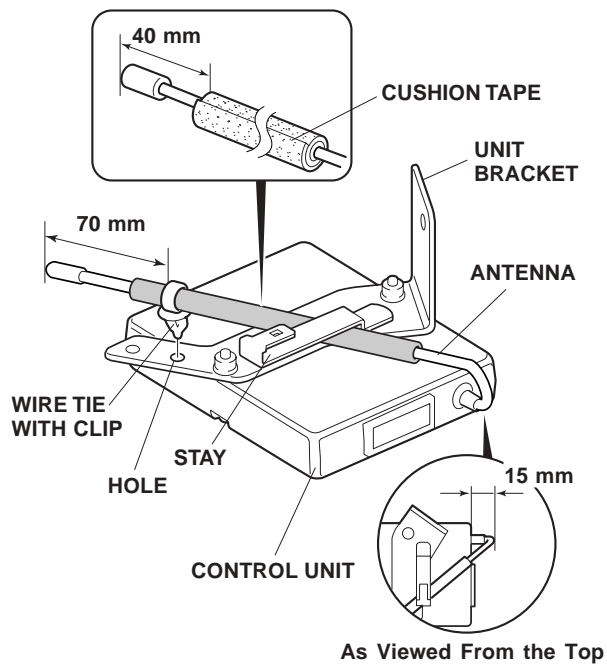

- Attach one wire tie with clip to the antenna, then push the clip of the wire tie into the hole in the unit bracket.
- Plug the relay into the relay block of the keyless entry harness, then slide the relay block onto the stay on the unit bracket.

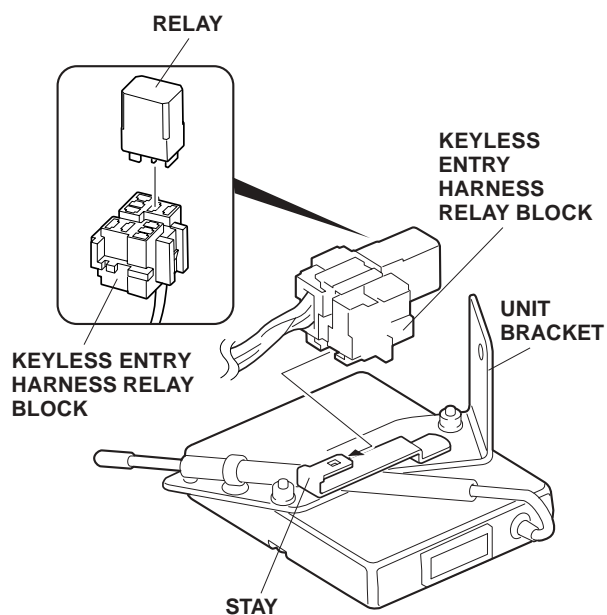

- Plug the 22-pin connector of the keyless entry harness into the control unit.

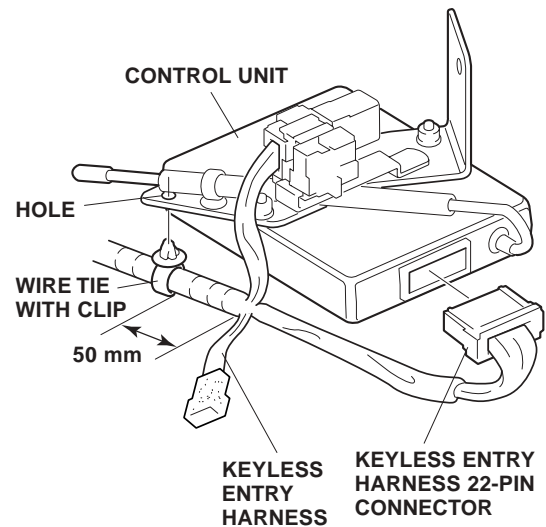

- Attach the other wire tie with clip to the keyless entry harness, then push the clip of the wire tie into the hole in the unit bracket.
- Remove the bolt that secures the front of the steering hanger beam bracket, then attach the unit bracket with this bolt. Torque the bolt to 19 to 24 N·m (14 to 18 lb·ft).

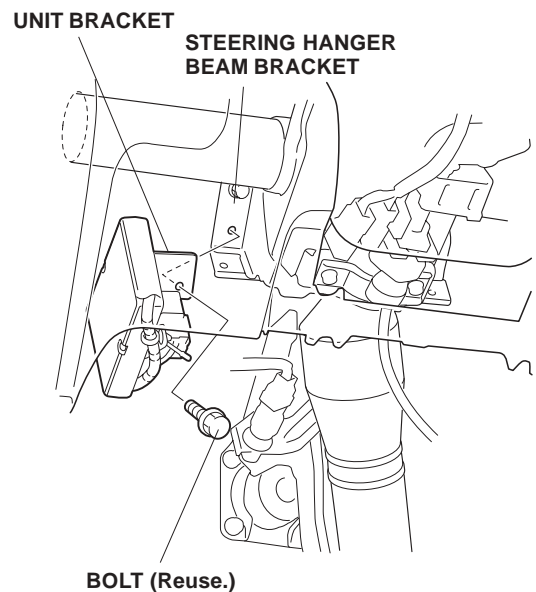

- Above the parking brake pedal bracket, locate the 3-pin connector blue-taped to the vehicle harness, and remove the blue tape to free the connector. Plug the 3-pin connector of the keyless entry harness into the 3-pin connector you just freed.

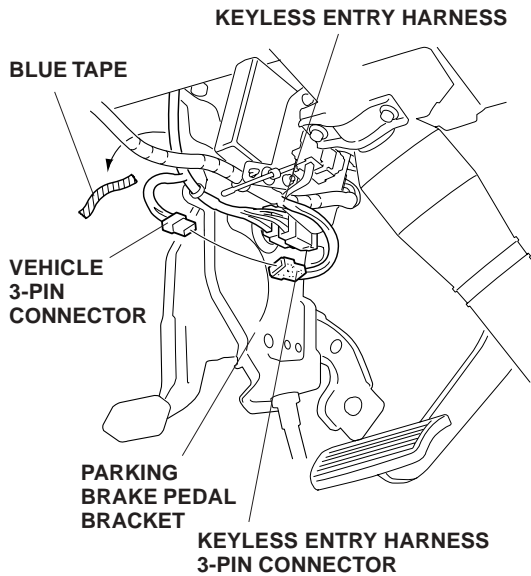

- Route the 6-pin connectors of the keyless entry harness to the switch trim opening. Plug the 6-pin connectors between the interior light switch and the interior light switch harness connector. Reinstall the switch trim.

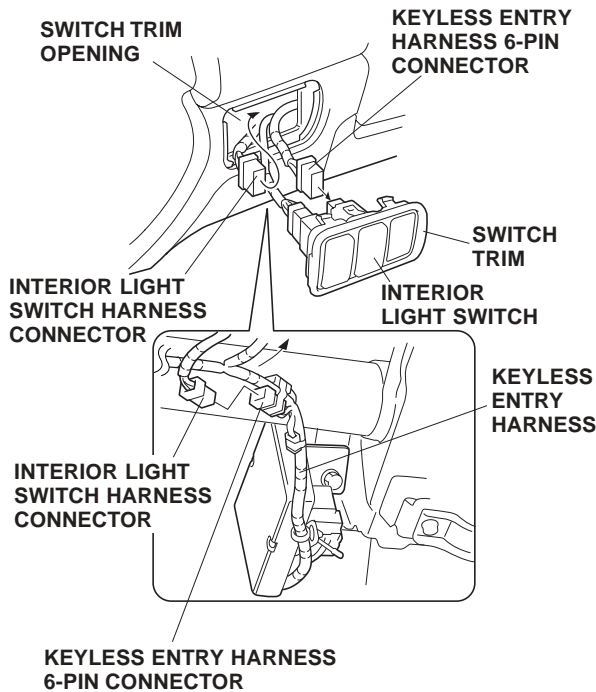

- Unplug the vehicle 10-pin connector from the fuse box, and plug the two 10-pin connectors of the keyless entry harness in between.

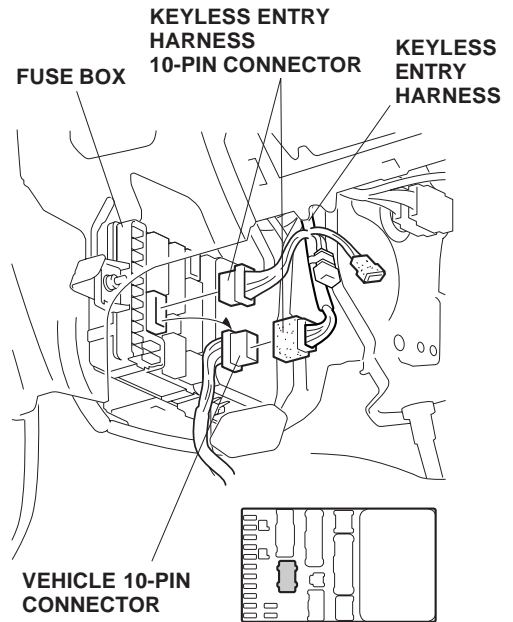

- Above the fuse box, locate the gray 2-pin connector blue-taped to the vehicle harness. This connector is difficult to see, it is behind a gray 4-pin connector. Pull the gray 4-pin connector down and out of the clip on the instrument panel bracket. Remove the blue tape securing the gray 2-pin connector and pull it out.

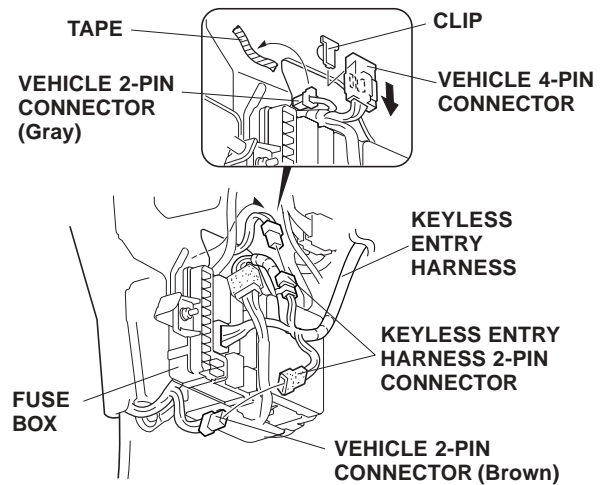

- Below the fuse box, locate the brown 2-pin connector. Plug the keyless entry harness 2-pin connectors into the brown connector and into the gray 2-pin connector from step 18. Reinstall the gray 4-pin connector.

20. Open the fuse case covers, and check the rating of each fuse. Attach the fuse labels (OPTION 5 A/2 A) to the fuse cases on the keyless entry harness.

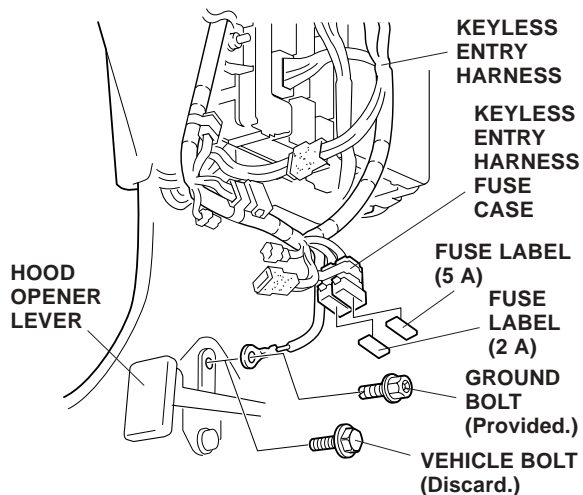

21. Remove the bolt that secures the top of the hood opener lever, then attach the ground terminal of the keyless entry harness with the ground bolt from the kit.
22. Attach the fuse label (KEYLESS ENTRY 2 A) to the fuse case on the keyless entry harness.

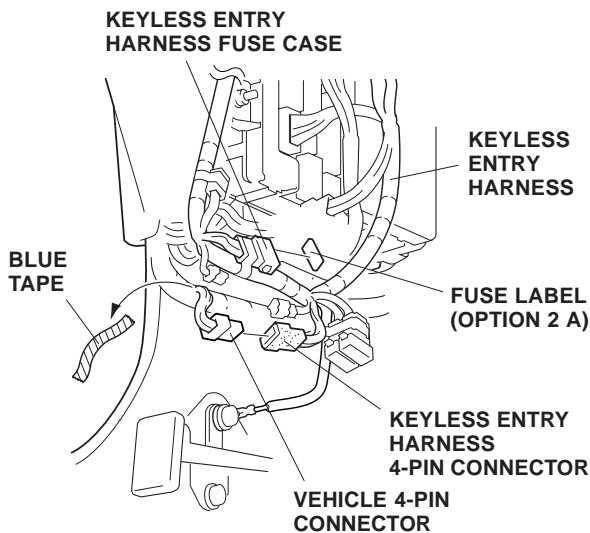

23. Under the fuse box, locate the 4-pin connector blue-taped to the vehicle harness, and remove the blue tape to free the connector. Plug the 4-pin connector of the keyless entry harness into the 4-pin connector you just freed.

24. Under the fuse box, push in the vehicle 1-pin connector to remove it from the vehicle connector, then remove the tape securing the vehicle 1-pin connector. Unplug the vehicle 1-pin connectors, and plug the 1-pin connectors of the keyless entry harness between the vehicle 1-pin connectors you just unplugged. Reinstall the vehicle 1-pin connector.

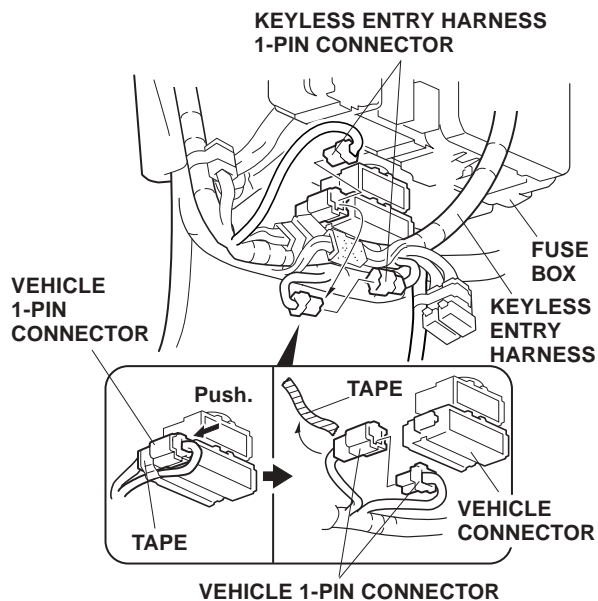

25. Using isopropyl alcohol on a shop towel, thoroughly clean the instrument panel side frame bracket in the area shown. Cut a cushion tape into halves, and attach the two pieces to the side frame bracket as described.

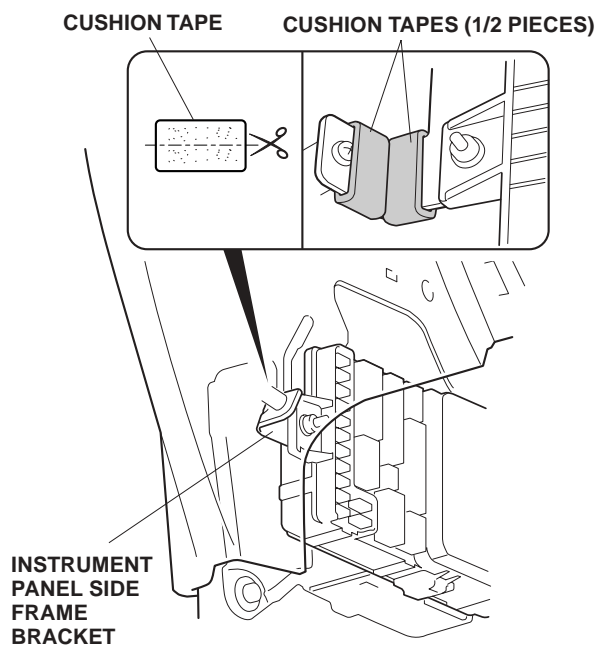

26. Secure the keyless entry harness to the vehicle harness with three wire ties in the areas shown.

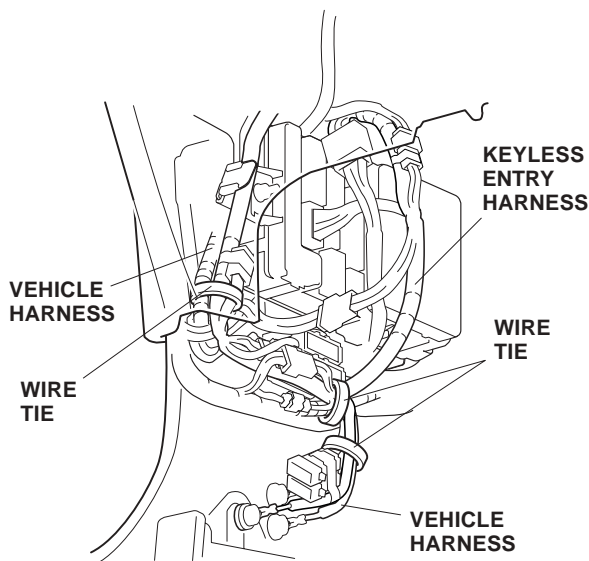

27. Further secure the keyless entry harness to the instrument panel side frame bracket and the vehicle harness with five wire ties in the areas shown.

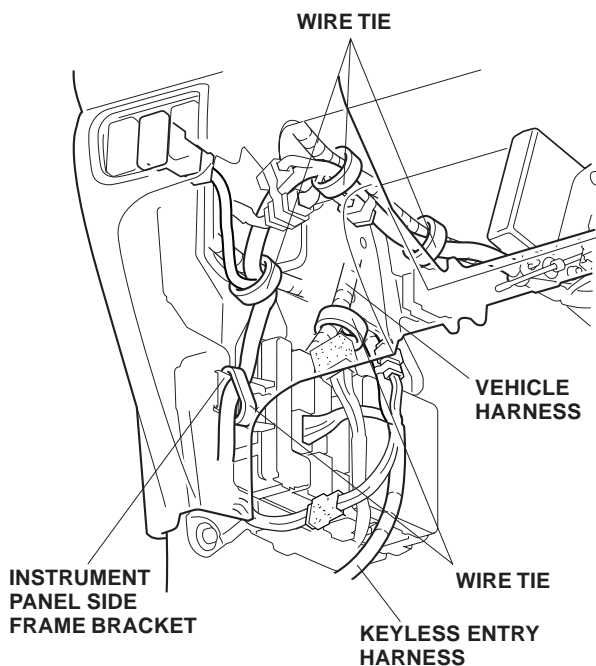

28. Check that all wire harnesses and cables are routed properly and all connectors are plugged in.
29. Reinstall all removed parts.
30. Reconnect the negative cable to the battery.
31. Enter the customer's radio anti-theft code, if applicable, and reset the radio station presets.
32. Set the clock.
33. Check operation of the keyless entry according to the Owner's Manual supplied.

NOTE: Whenever the battery is disconnected, the driver's window AUTO function is disabled.

34. Start the engine. Push down on the driver's window switch until the window is fully open.
35. Pull up on the driver's window switch to close the window completely, then hold the switch for 2 seconds.
36. Lower and raise the driver's window to check operation of the driver's window AUTO function.
37. Do the PCM idle learn procedure.
 - Make sure all electrical items are turned off.
 - Start the engine. Hold the engine speed at 3,000 rpm with no load (in Park or Neutral) until the radiator fan comes on.
 - Let the engine idle for about 5 minutes with the throttle fully closed and with all electrical items off.

NOTE: If the radiator fan comes on during this step, the time when it is operating must not be included in the 5 minutes.