



INSTALLATION INSTRUCTIONS

Accessory

WING SPOILER

Application

2007 S2000

Publications No.

All 33383

Issue Date

AUG 2006

PARTS LIST

Wing spoiler

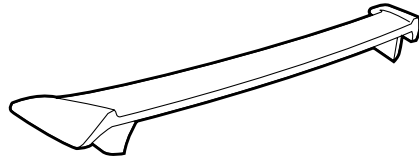

2 Cap nuts



2 Washer-screws



4 Adhesive washers



Left trunk spring
(without cushion)

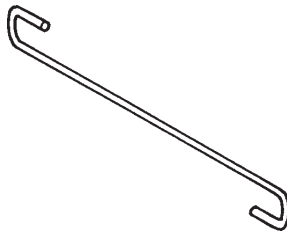

Right trunk spring
(with cushion)

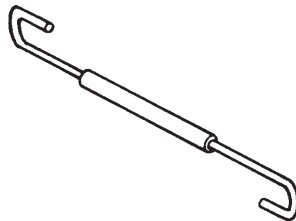

Template

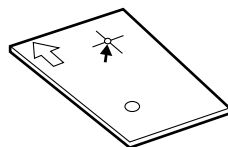

TOOLS AND SUPPLIES REQUIRED

Phillips screwdriver (magnetic)

Ratchet

10 mm Socket

Drill

3 mm and 8 mm Drill bits

Masking tape

Felt-tip pen

Center punch

File

Isopropyl alcohol

Shop towel

Eye protection (safety goggles, face shield, etc.)

Touch-up paint

Trunk spring installer/remover: T/N 08M10-SM4-100

Heavy gloves

INSTALLATION

NOTE:

- Have an assistant hold the trunk lid open when replacing the trunk springs.
- The trunk spring with the cushion goes on the right side; the spring without the cushion goes on the left side.
- Be careful not to damage the body paint.

- Using a felt-tip pen, mark each of the two trunk lid stops and the trunk lid as shown. Remove the stops by turning them counterclockwise.

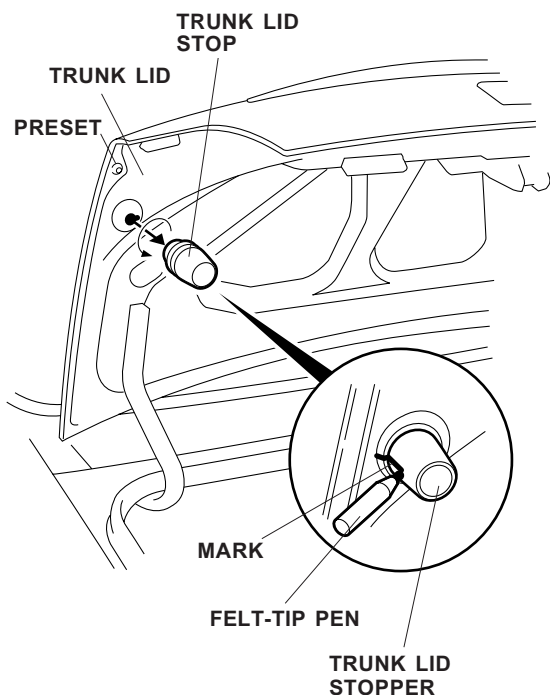

- To prevent metal shavings from falling into the trunk lid stopper holes, attach masking tape to the trunk lid in the areas shown.

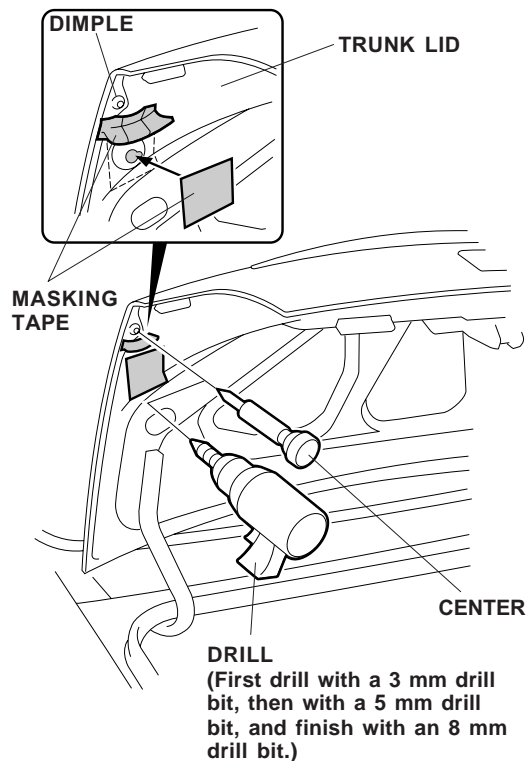

- On the inside of the trunk lid, find the dimple (preset) on the edge, and center-punch it twice. Using a drill and drill bits, drill an 8 mm hole through the trunk lid at the center-punched mark:
 - If you can't find the dimple, remove the seal a little with a flat-tip screwdriver in the area shown.
 - Before drilling, place a cover sheet under the trunk lid to prevent metal shavings from falling into the trunk.
 - When drilling the hole, wear a face shield or safety goggles to prevent eye injury.
 - First drill with a 3 mm drill bit, then with a 5 mm drill bit, and finish with an 8 mm drill bit.
 - After drilling, clean up all metal shavings carefully to avoid damage to the body paint.
 - Remove any burrs from the edge of the hole with a file, and apply touch-up paint. Allow the touch-up paint to dry thoroughly before the next step.
- Repeat steps 1 through 3 for the right side.

- Close the trunk lid. Position the template on the trunk lid over the hole drilled in step 3. Using a felt-tip pen, mark the trunk lid at the remaining hole in the template.

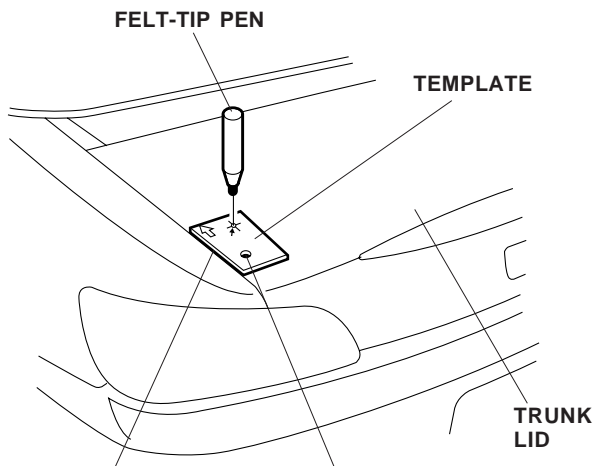

Position the template on the trunk lid so that the outer edge of the template is parallel with the edge of the trunk lid.

Align the hole in the template with the hole in the trunk lid drilled in step 3.

- To prevent the metal shavings from entering the inside, use masking tape to cover the clearance between the trunk lid and the body.
- Lightly center-punch the mark made in step 5. While wearing eye protection, drill an 8 mm hole through the trunk lid at the center-punched mark:
 - To prevent drilling through the inner panel, wrap masking tape around the drill bit 10 mm away from the tip.
 - First drill with a 3 mm drill bit, then with a 5 mm drill bit, and finish with an 8 mm drill bit.
 - After drilling, clean up the metal shavings carefully to avoid damage to the body paint.
 - Remove any burrs from the edge of the hole with a file, and apply touch-up paint. Allow the touch-up paint to dry thoroughly before the next step.

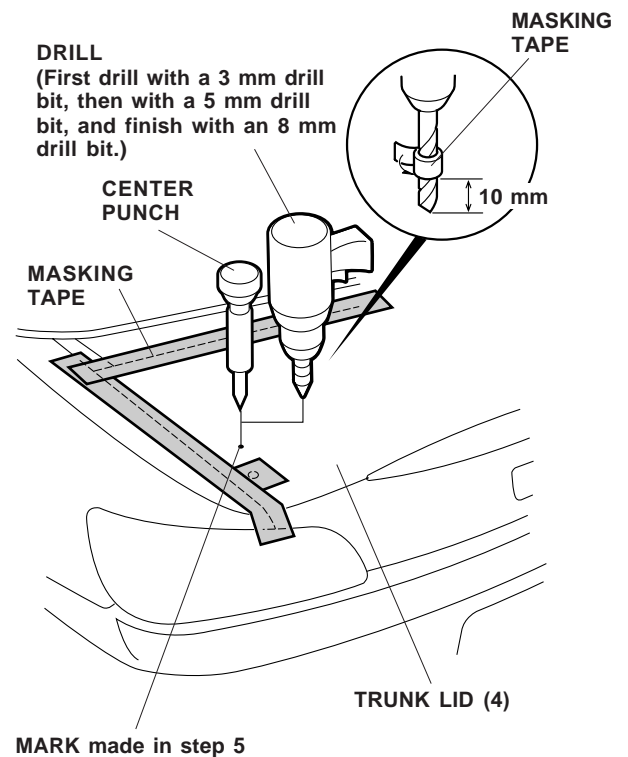

- Turn the template over, and repeat steps 5 through 7 to mark and drill on the right side of the trunk lid.
- Remove the masking tape from the trunk lid.

Installing the Wing Spoiler

1. Using isopropyl alcohol on a shop towel, clean the area around the holes where the adhesive washers will attach.
2. Remove the backings, and attach one of the adhesive washers over each of the four holes in the trunk lid.

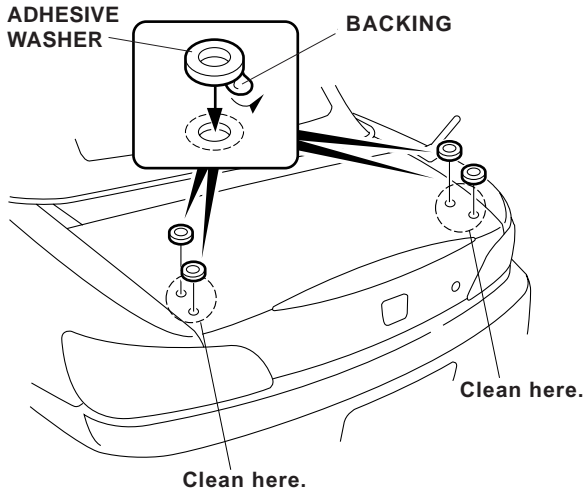

3. On the back of the wing spoiler, peel back 1 to 1½ inches of the backings from the adhesive tapes, and tape them to the front of the trunk spoiler with masking tape.

ADHESIVE TAPE BACKINGS
(Peel back the adhesive backing from the adhesive tape a little, and attach it to the front of the wing spoiler.)

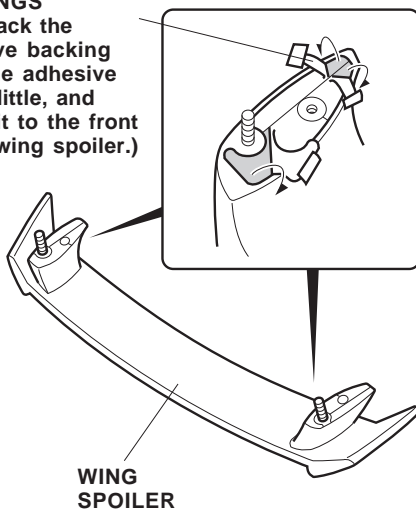

4. Position the wing spoiler on the trunk lid, and insert the studs into the holes in the trunk lid. Open the trunk lid, and install a cap nut on the end of each stud. Do not tighten the cap nuts yet. Be careful not to damage the body paint with the studs.
5. Using a magnetic Phillips screwdriver, insert a washer-screw into the hole where the trunk lid stopper was removed. Do not tighten the washer-screws yet. Repeat on the other side.

NOTE: Be careful not to drop the washer-screws into the trunk lid; they are difficult to get out.

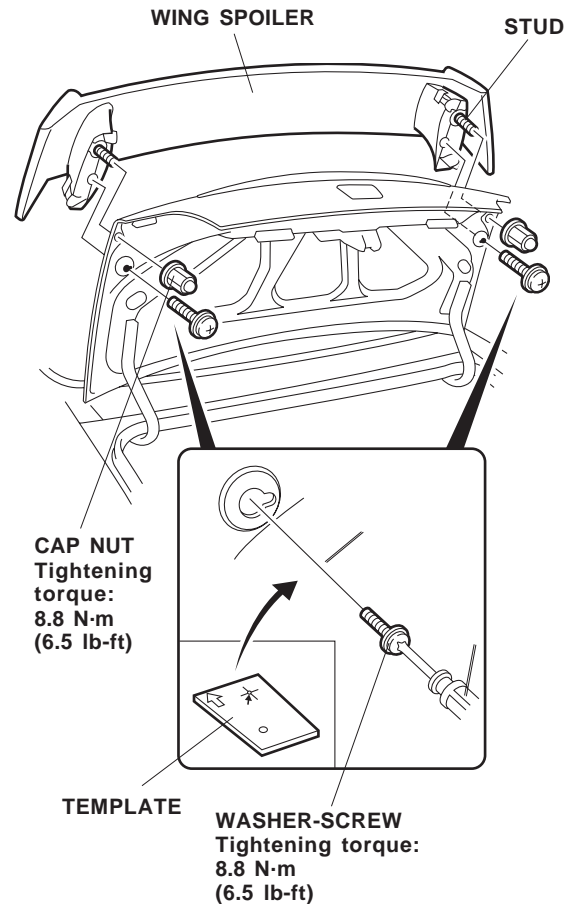

6. Remove each of the backings, then hold the wing spoiler firmly against the trunk lid with the palm of your hand, especially at the edges.

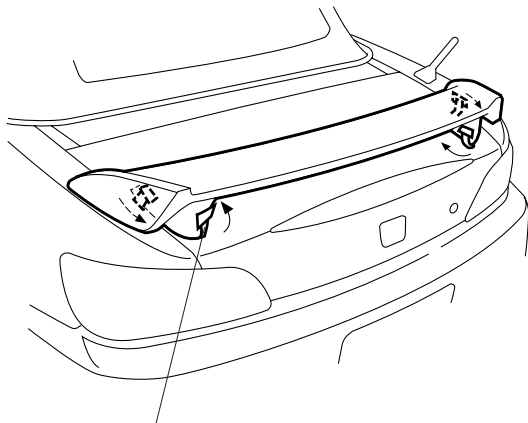

BACKING
(Carefully remove while holding pressure on the wing spoiler.)

7. Tighten the cap nuts and washer-screws temporarily installed in steps 4 and 5. Torque the cap nuts and washer-screws to 8.8 N·m (6.5 lb-ft).
8. Reinstall the trunk lid stops by aligning them to the marks you made in step 1.

Replacing the Trunk Springs

9. Open the trunk lid, and take out the tool box. Remove the three anchor bolts that secure the right front trunk lining, and remove the lining.

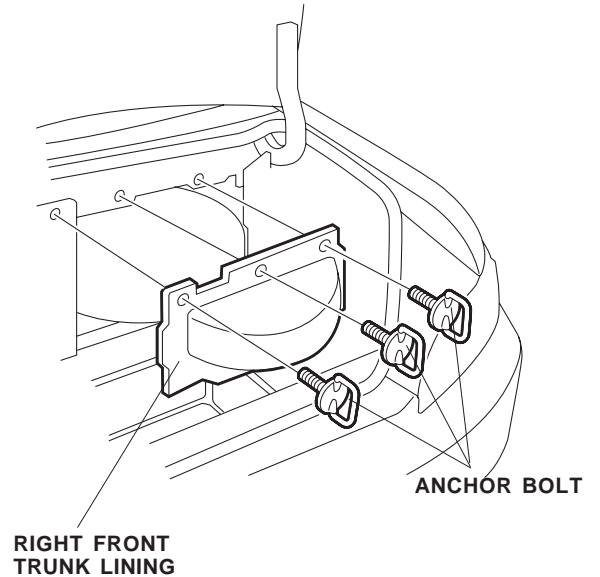

10. Remove the two clips that fasten the left trunk side lining, and pull the lining out in the direction shown.

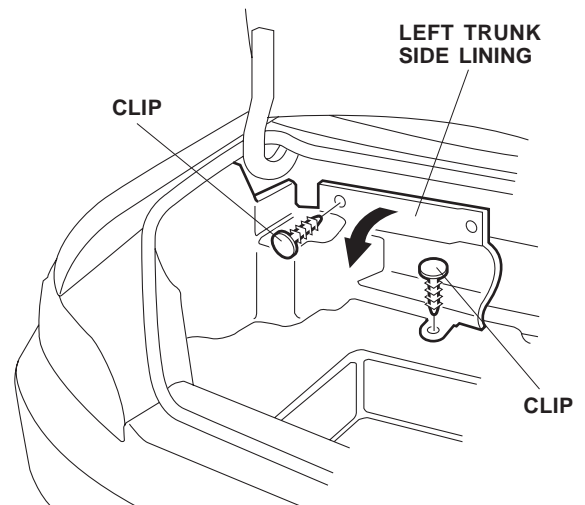

11. With an assistant holding the trunk lid open, remove the old trunk springs from the trunk hinge arms using the special tool. Wearing heavy gloves to protect your hands, pull the special tool slowly and carefully toward you.

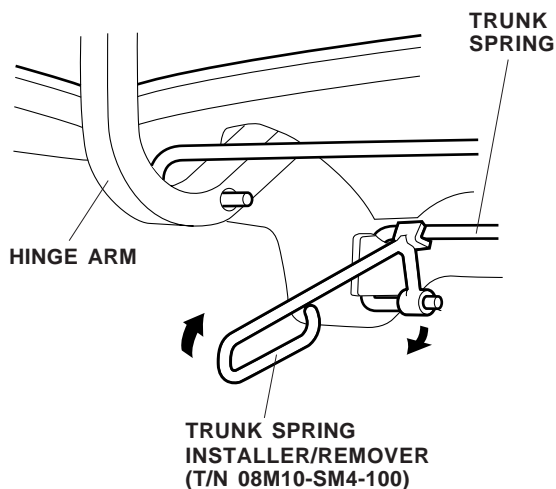

12. Install the new heavy-duty trunk springs with the tool in the reverse order of removal. Install the left spring without cushion first.

- Install the left trunk spring (without cushion) on the left trunk hinge arm, and install the right trunk spring (with cushion) on the right trunk hinge arm.
- While still wearing gloves, rotate the tool as you pull it toward you.
- Set the springs in the original position of the hinge arms.

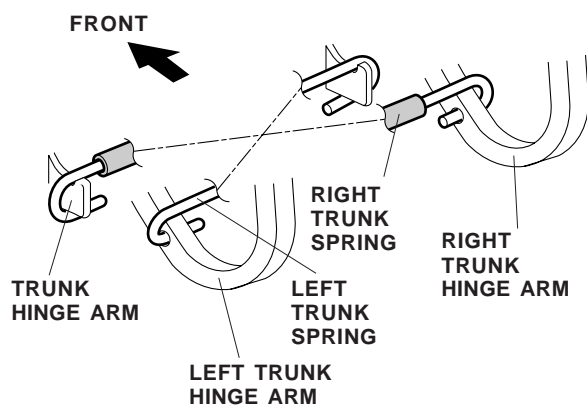

Use and Care of the Wing Spoiler

- Handle the wing spoiler with care; it is not designed to absorb impact.
- Check the wing spoiler mounting nuts and bolts periodically, and retighten them if necessary.