

**PARTS LIST**
**Backup Sensors Attachment Kit  
P/N 08V67-T6Z-100A**

Control unit



Buzzer



Switch



Backup sensor harness



Subharness

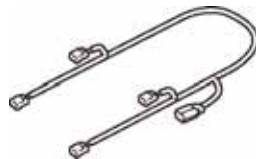

Control unit bracket



2 Black sensor clips



2 White sensor clips



Switch bracket



23 Wire ties



Narrow wire tie



4 Wire ties with clip A



6 Wire ties with clip B



4 Wire ties with clip C

Clip



Aluminum tape



Fuse label

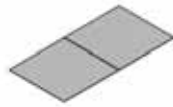

Ground bolt



Accessory user's information manual



**Backup Sensors Kit  
P/N 08V67-T6Z-100K**

NOTE: Refer to parts information bulletin (PIB) for the proper color sensors.

Right center sensor  
(Blue)



Left center sensor  
(Blue) (Yellow dot label)



Right corner sensor  
(White) (Yellow dot label)



Left corner sensor  
(White)



## TOOLS AND SUPPLIES REQUIRED

Phillips screwdriver  
Small flat-tip screwdriver  
10 mm Open end wrench  
10 mm and 14 mm Sockets  
Pushpin  
Ratchet  
3 mm Drill bit  
Eye protection (face shield, safety goggles, etc.)  
File  
Ruler  
Blanket  
Isopropyl alcohol  
Shop towel  
24 mm and 26 mm Hole saws  
Drill  
Masking tape  
Diagonal cutters  
Torque wrench  
Rubber mallet  
T-40 and T-50 TORX bits  
Utility knife

*The following tool is available through the Honda Tool and Equipment Program. On the iN, click on: Service > Service Bay > Tool and Equipment Program, then enter the number under "Search." Or, call 888-424-6857.*

Plastic Trim Tool (T/N SILTRIMTL10)

## Illustration of the Backup Sensors on the Vehicle

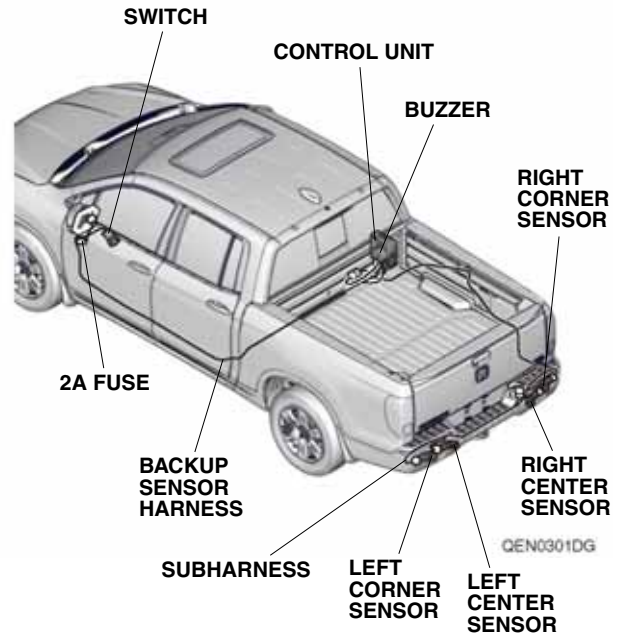

## INSTALLATION

**Customer Information:** The information in this installation instruction is intended for use only by skilled technicians who have the proper tools, equipment, and training to correctly and safely add equipment to your vehicle. These procedures should not be attempted by “do-it-yourselfers.”

NOTE: Refer to parts information bulletin (PIB) for the proper color sensors.

1. Disconnect the negative cable from the battery:
  - Wrap a shop towel around the hood latch.

**HOOD LATCH**  
(Wrap with a shop towel.)

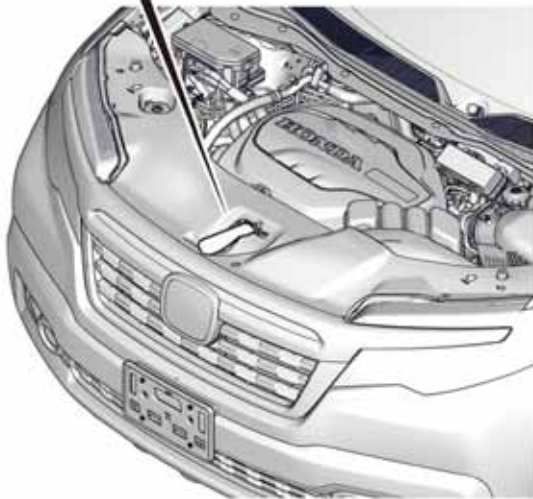
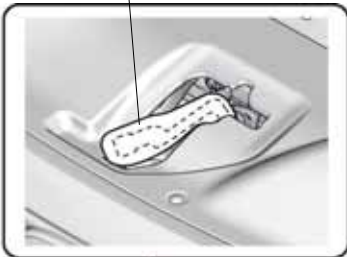

QE014028B

- Remove the front bulkhead cover.

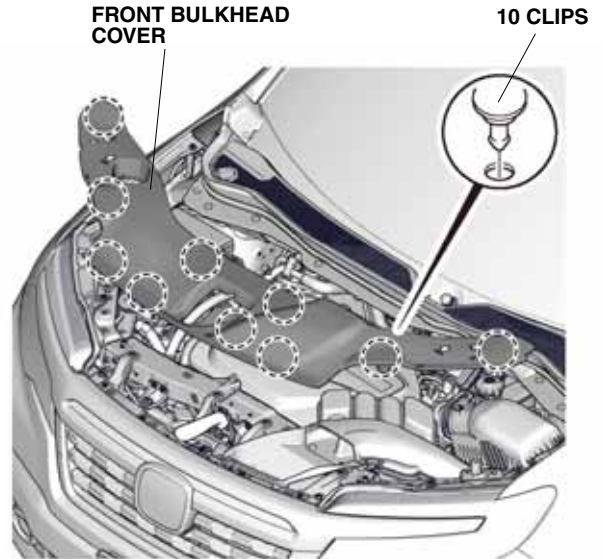

QE01403AB

- Remove the intake air tube.
- Disconnect the negative cable from the battery.

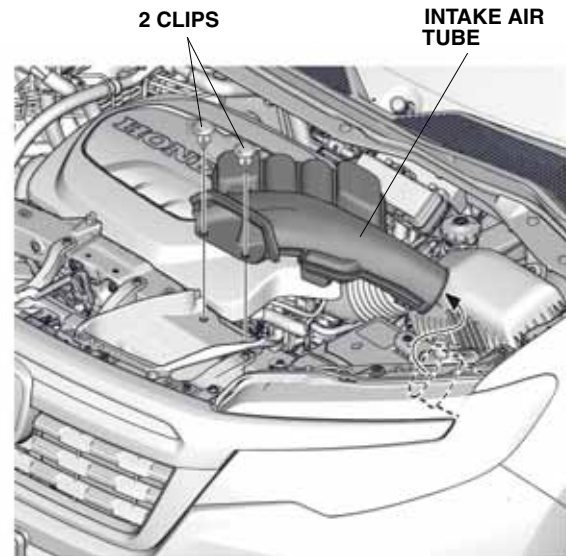

QE01404AB

2. Pull away the door opening seal and remove the driver's dashboard side lid.

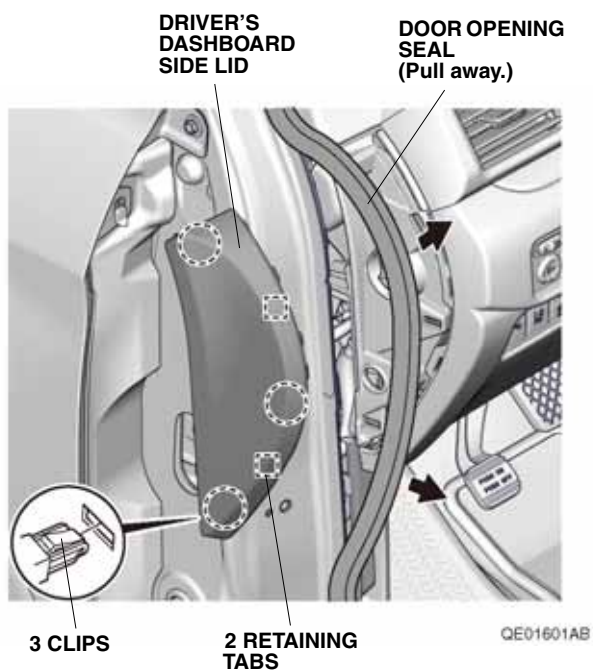

3. Remove the driver's dashboard lower cover release the vehicle sensor.

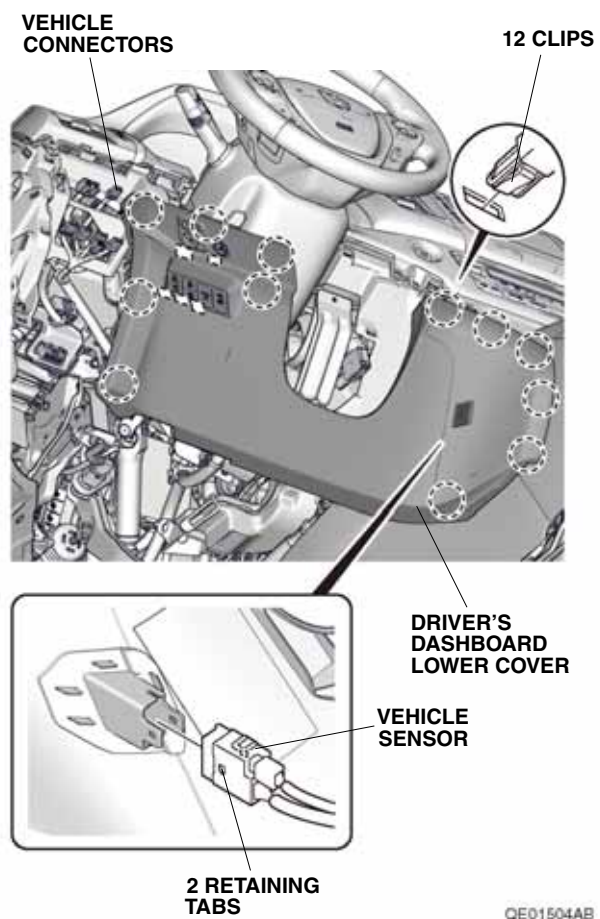

4. Remove the driver's door sill trim.

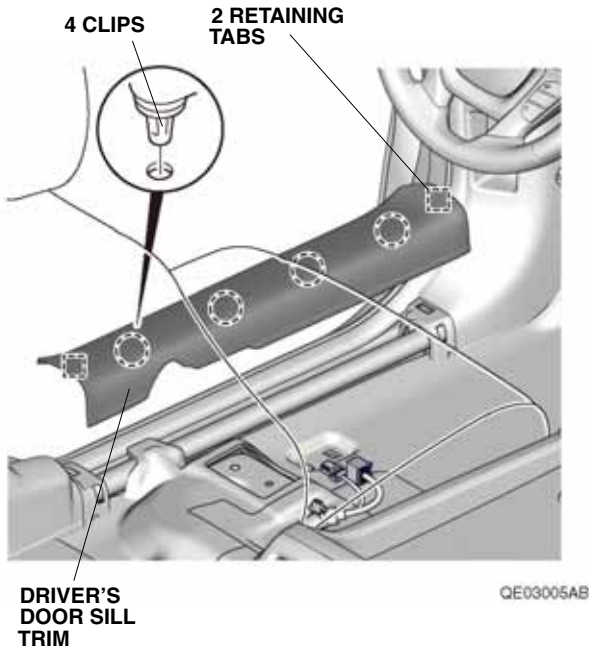

6. Remove the left rear door sill trim.

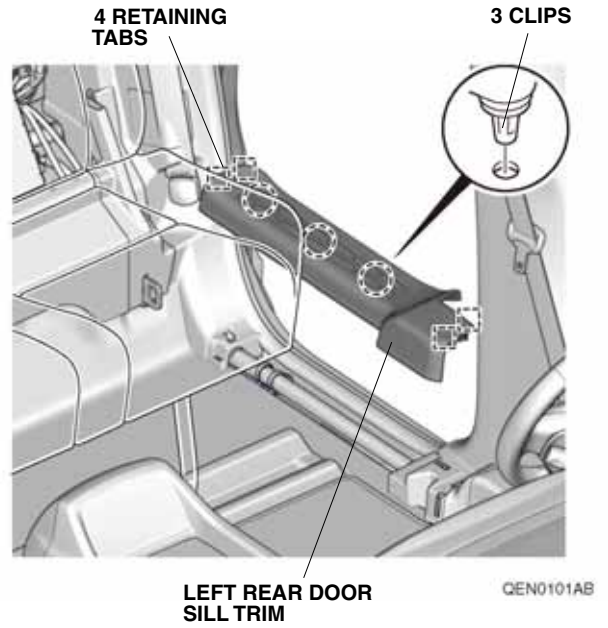

5. Pull away the door opening seal and remove the driver's kick panel.

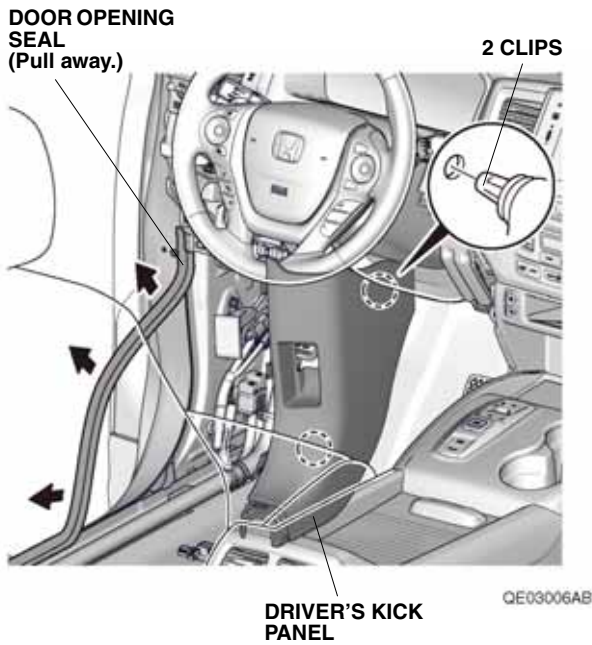

7. Remove the left B-pillar lower trim cover.

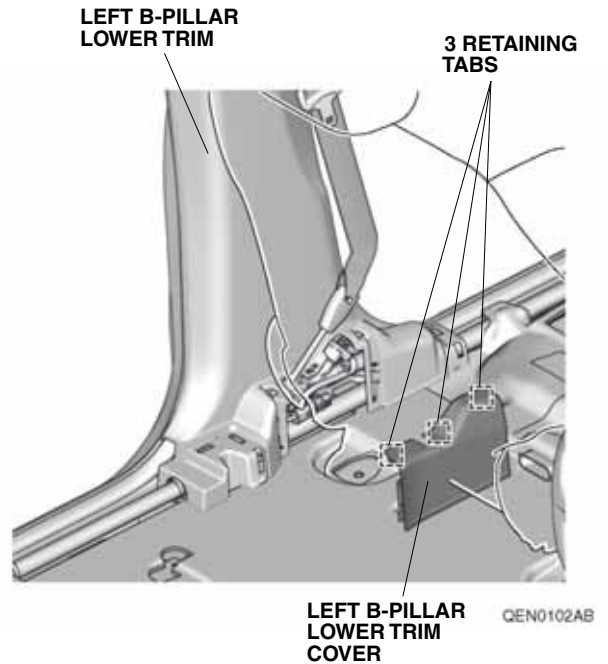

8. Remove the left B-pillar lower trim.

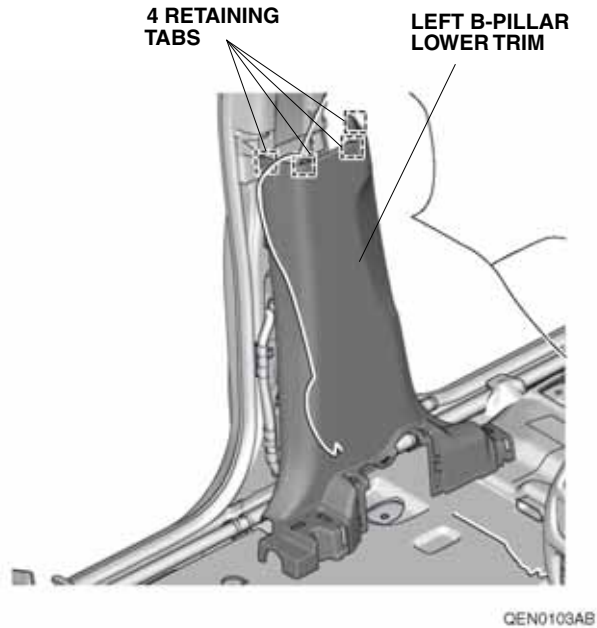

9. Raise the rear seat cushions. Remove the left rear under-seat trim panel.

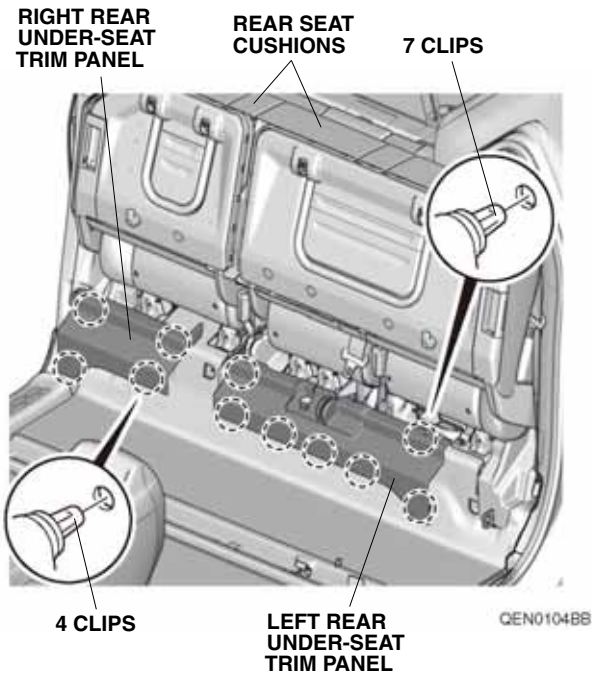

10. Remove the right rear under-seat trim panel (four clips).

11. Remove the left and right rear seat mount covers.

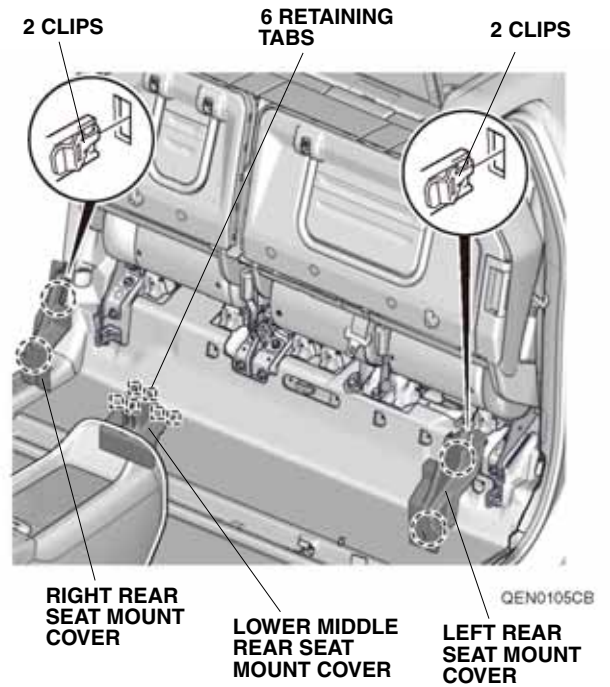

12. Remove the lower middle rear seat mount cover.

13. Remove the nine bolts. Torque the bolts to 41.0-53.0 N·m (30-39 lb·ft).

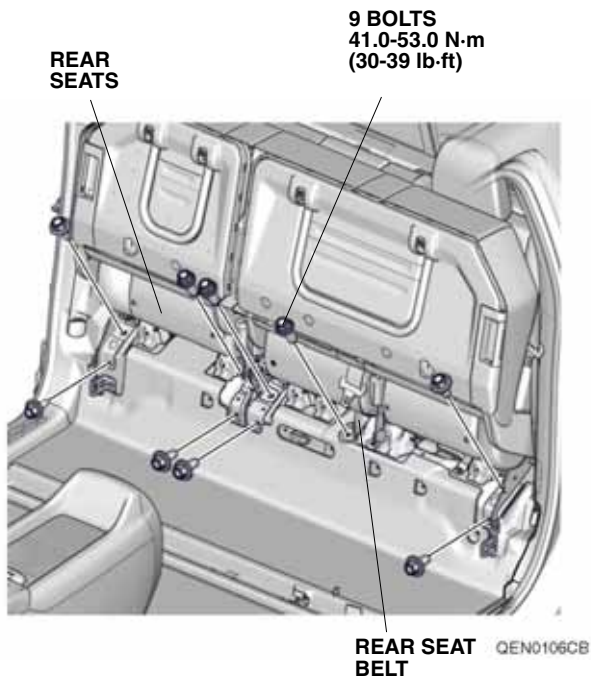

14. Remove the two caps from the rear trim panel cover.

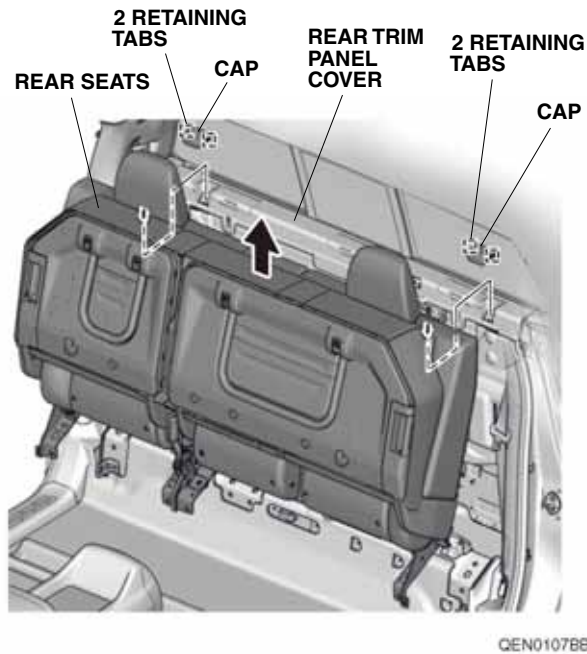

15. With the help of an assistant, remove the rear seats.

16. Remove the subwoofer and unplug the vehicle connector.

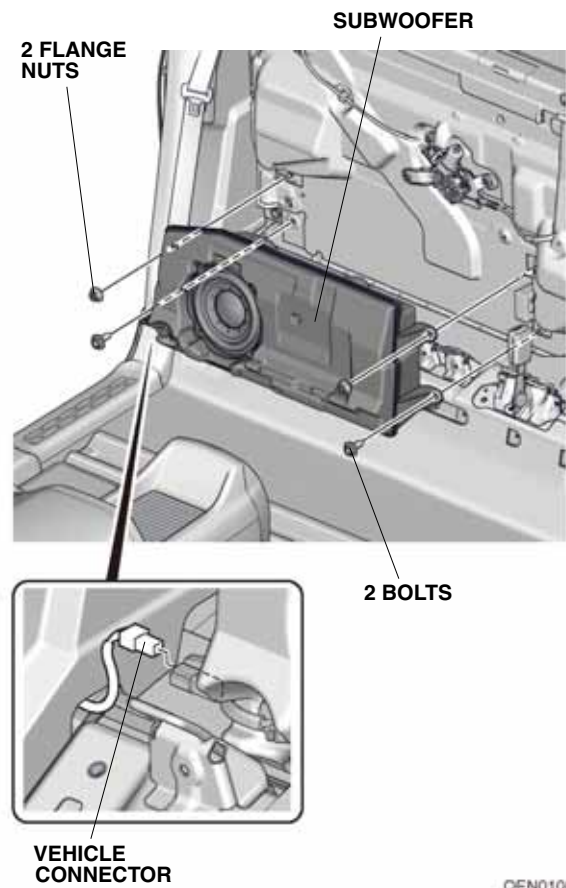

17. Remove the rear trim panel cover.

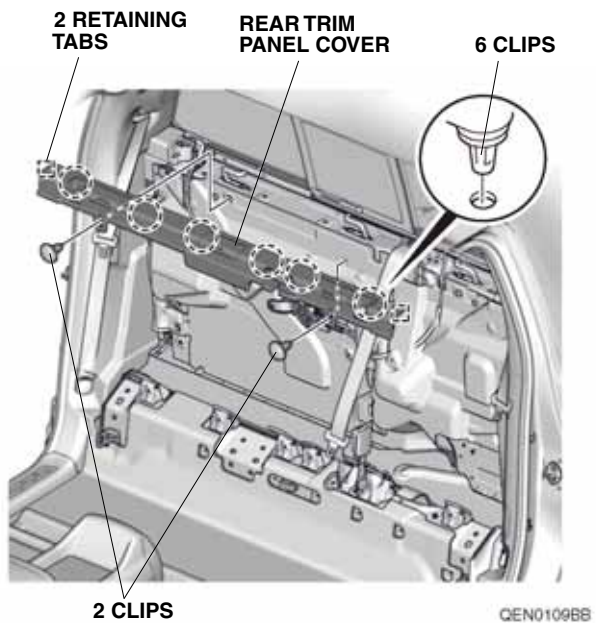



18. Pull up the left rear seat belt lower anchor bolt cover and remove the left rear seat belt lower anchor bolt. Torque the left rear seat belt lower anchor bolt to 29.4-48.0 N·m (22-35 lb·ft).

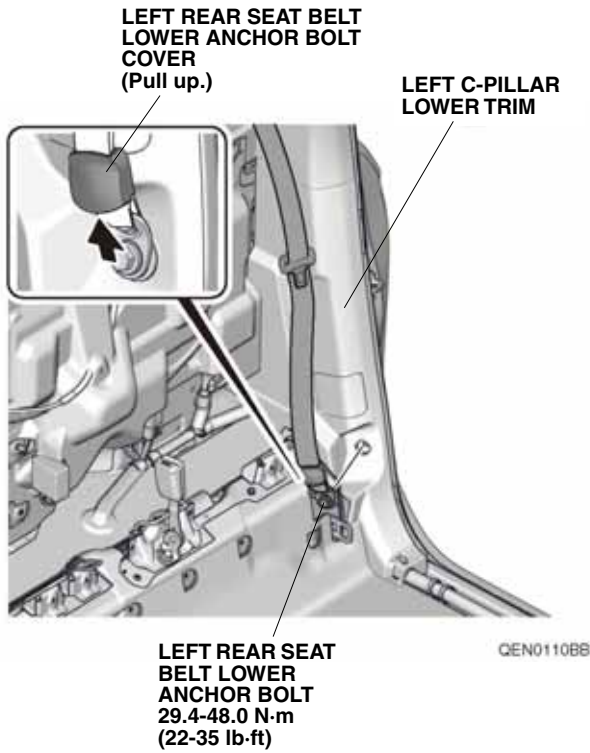

19. Pull away the door opening seal from around the left C-pillar upper trim.

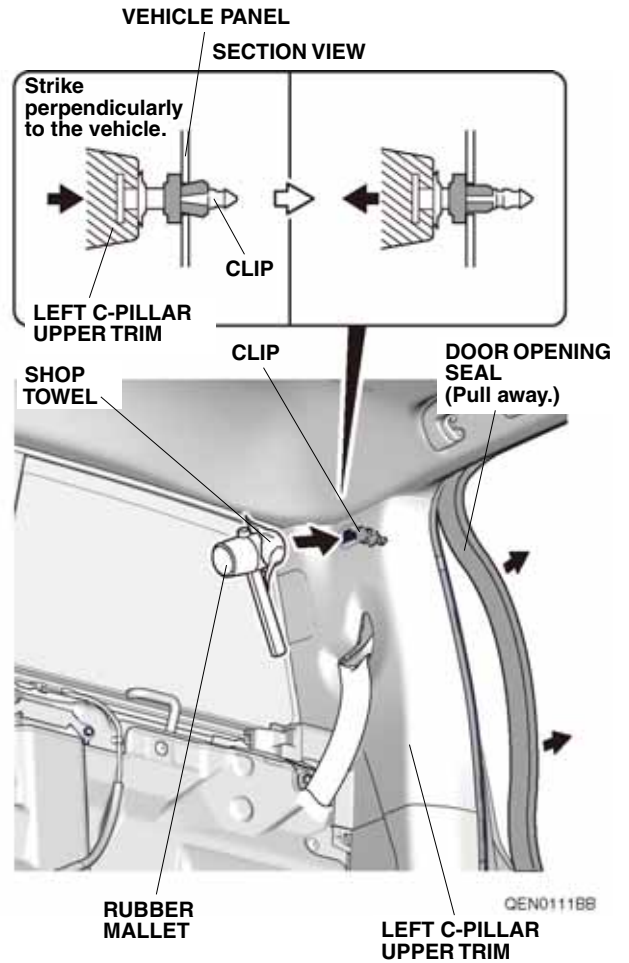

20. Using a rubber mallet wrapped with a shop towel, lightly tap the area marked "SIDE CURTAIN AIRBAG" on the left C-pillar upper trim to push in the clip.  
NOTE: Make sure to strike the area perpendicular to the vehicle.

21. Remove the left C-pillar upper trim.

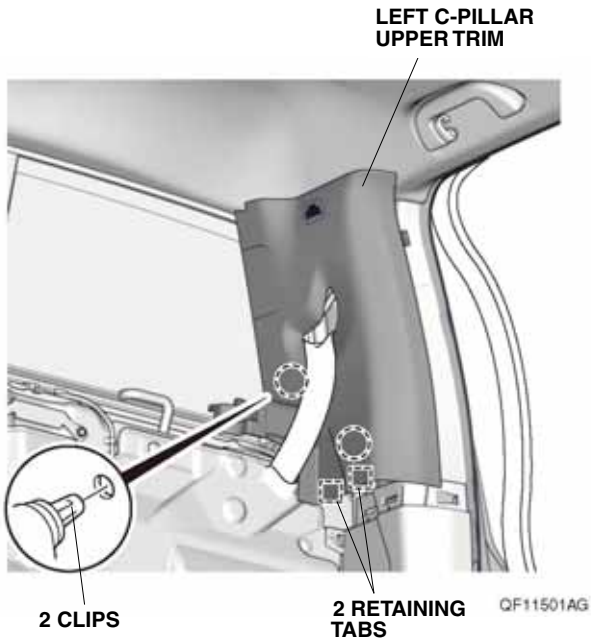

22. Pull away the door opening seal from around the left C-pillar lower trim.

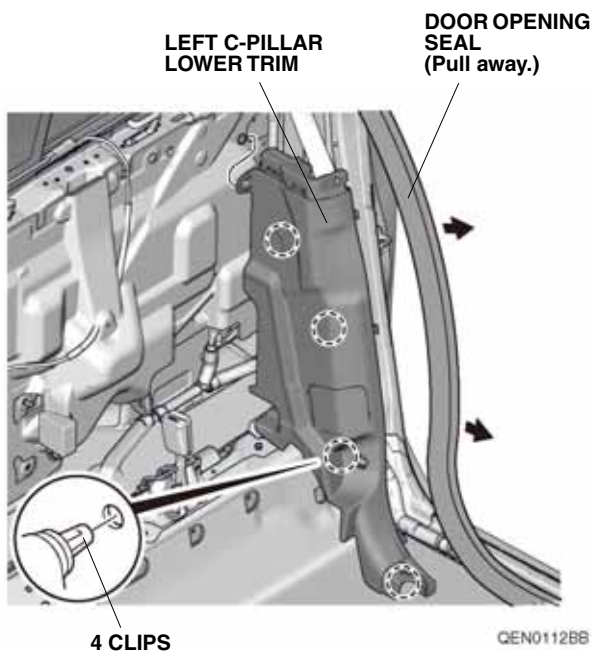

23. Remove the left C-pillar lower trim.

24. Remove the right front upper tie-down hook (two TORX bolts). Torque the TORX bolts to 18.63-24.52 N·m (14-18 lb·ft).

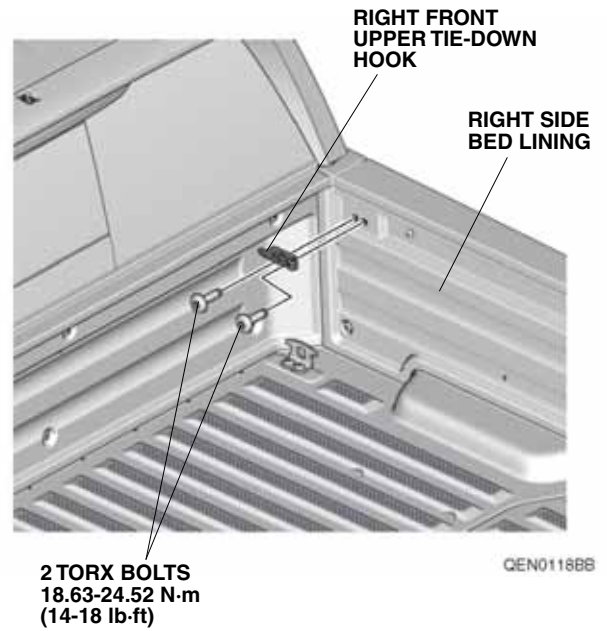

25. Lower the tailgate. Remove the screw cover from the right bed rail trim.

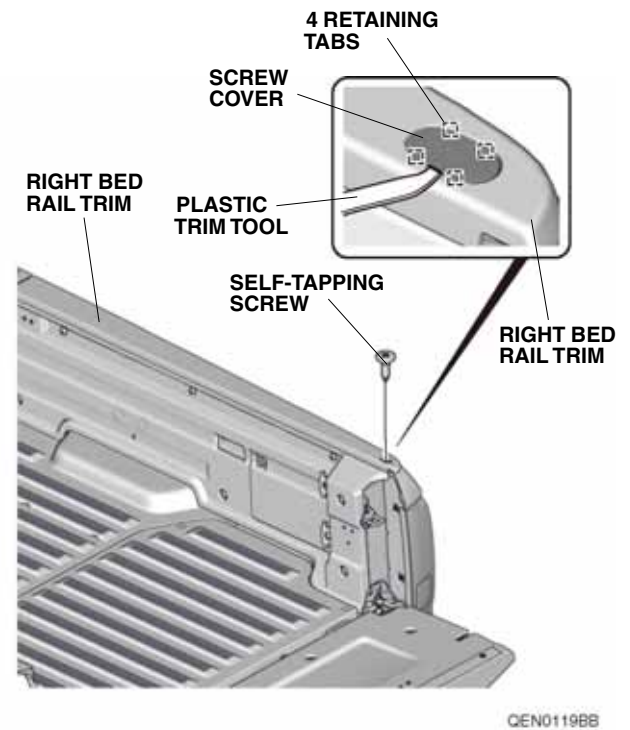

26. Remove the self-tapping screw.

27. Remove the right bed rail trim.

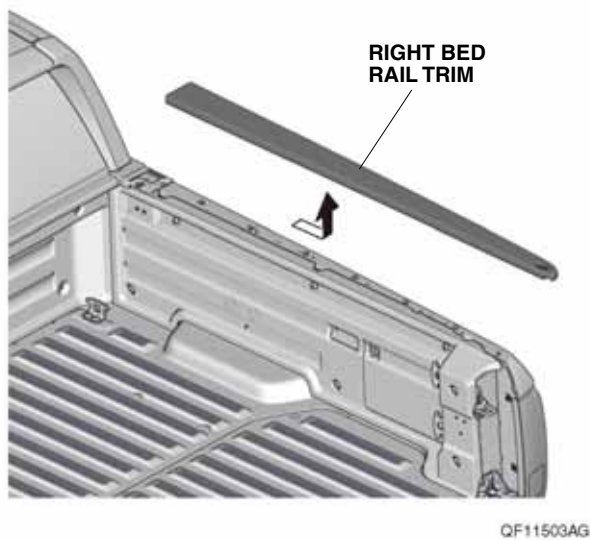

28. Remove the two right rear tie-down hooks. Torque the TORX bolts to 18.63-24.52 N·m (14-8 lb-ft).

**4 TORX BOLTS**  
18.63-24.52 N·m  
(14-8 lb-ft)

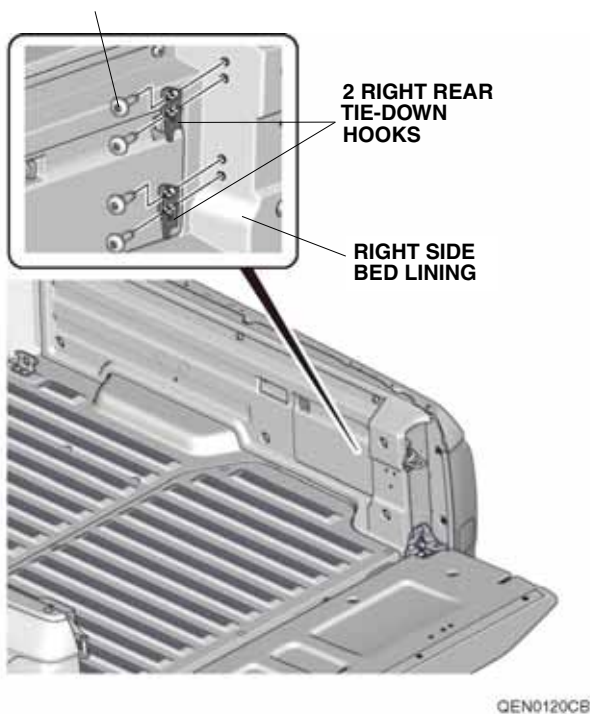

29. Remove the right side bed lining and unplug the vehicle connectors. Torque the TORX bolts to 6.86-11.77 N·m (5.1-9 lb-ft).

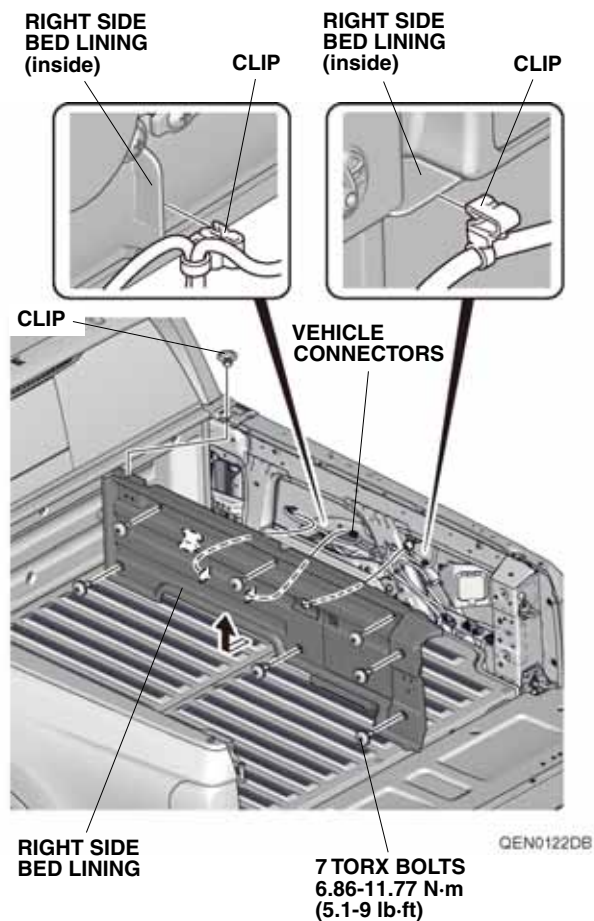

30. Remove the five self-tapping screws from the left rear wheel arch protector.

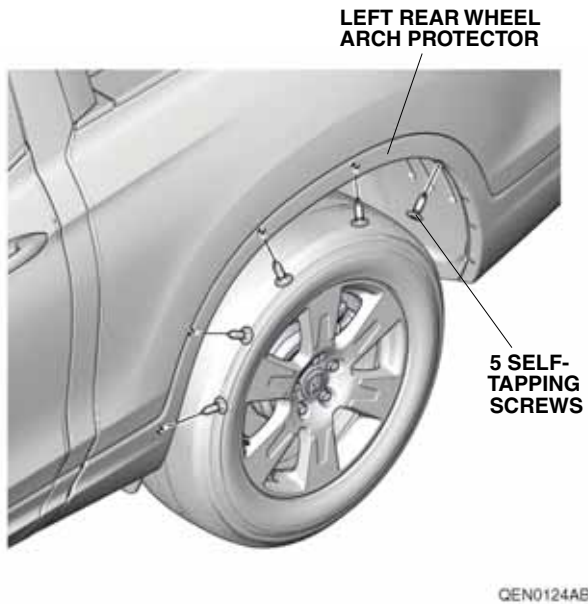

31. Remove the left rear wheel arch protector.

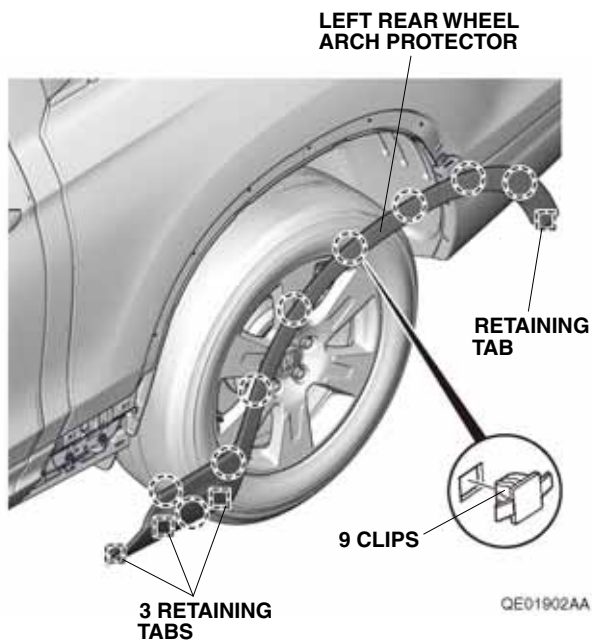

32. Repeat steps 30 and 31 on the right side of the vehicle.

33. Close the tailgate. Apply masking tape as shown on each side.

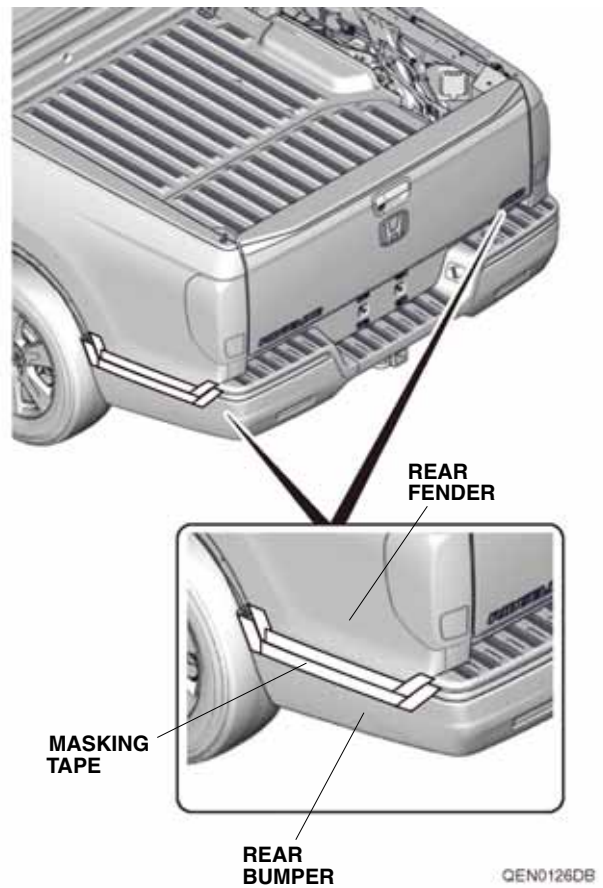

34. Remove the rear bumper:
- Remove the two washer-bolts, 10 self-tapping screws, and two clips.

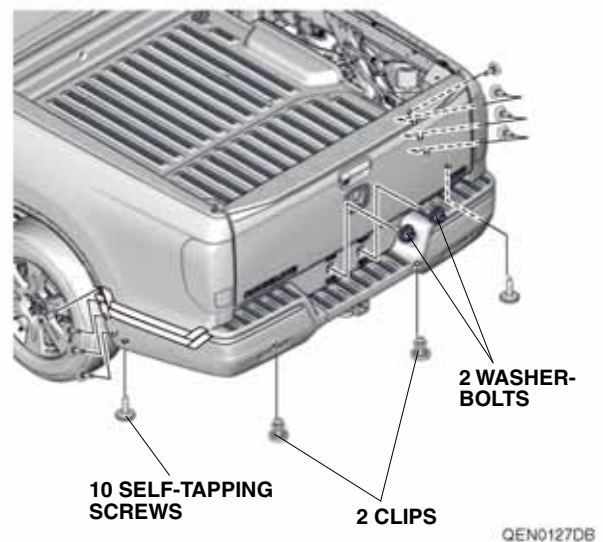

- On each side, release the seven retaining tabs along the fenderwell.

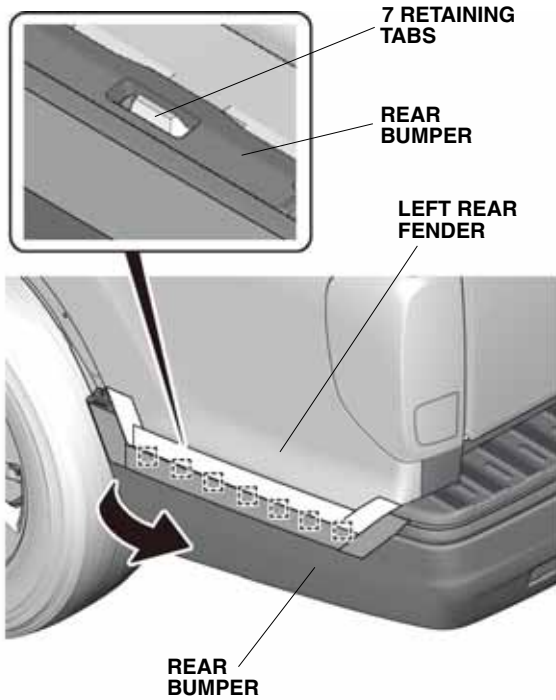

QEN0128AB

- With the help of an assistant, remove the rear bumper and unplug the vehicle connectors.
- Place the rear bumper on a blanket.

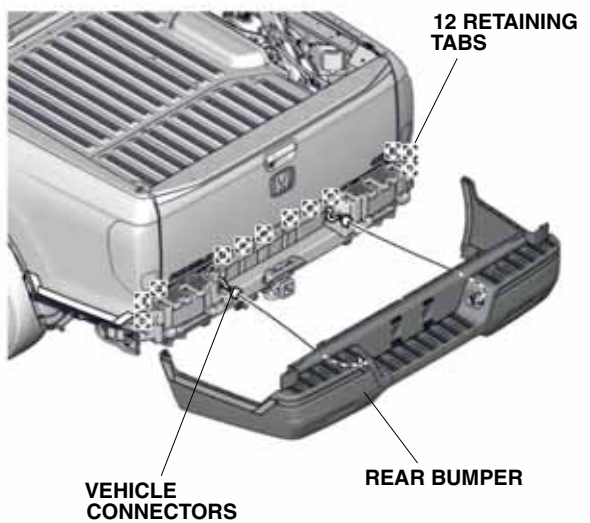

QEN0129BB

- Remove the left and right rear step supports.

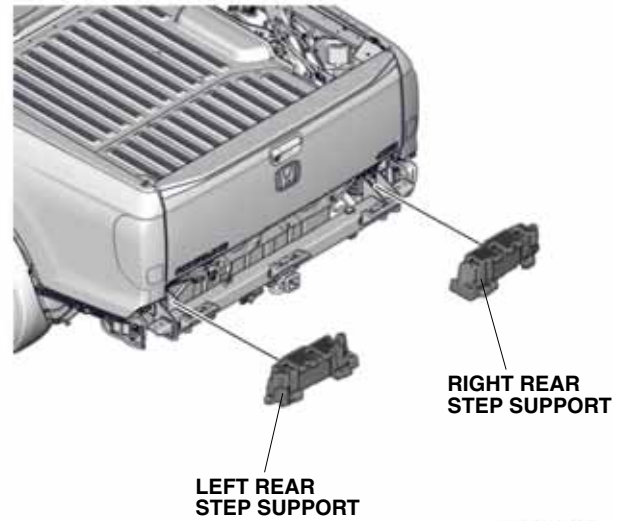

QF11504BG

- Using isopropyl alcohol on a shop towel, thoroughly clean the fuse case where the fuse label will attach. Attach the 2 A fuse label to the fuse case on the backup sensor harness.

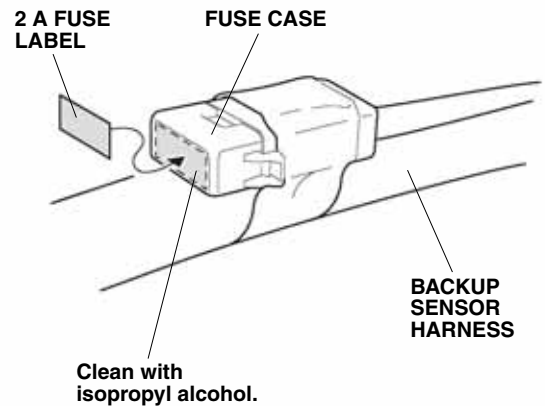

QDD0311AG

37. Plug the backup sensor harness 8-pin connector into the fuse box.

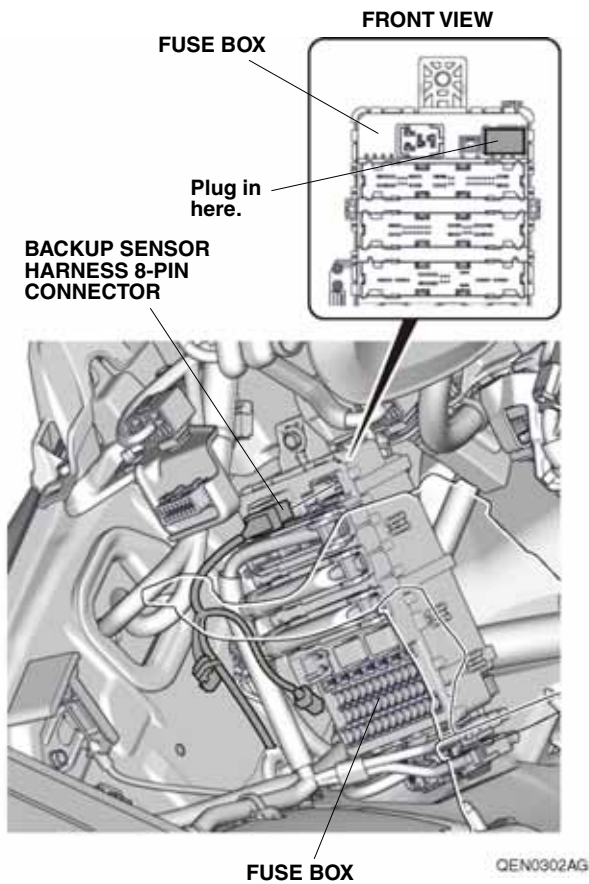

38. Secure the backup sensor harness to the vehicle harness with two wire ties.

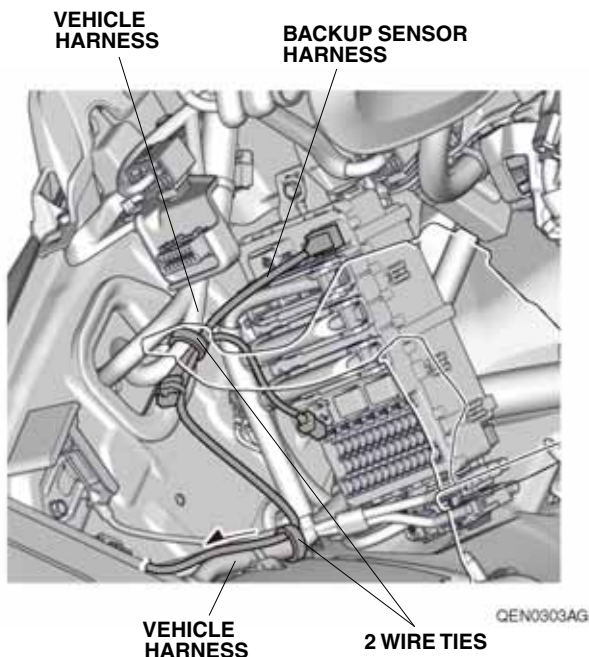

39. Secure the backup sensor harness to the vehicle harness with three wire ties.

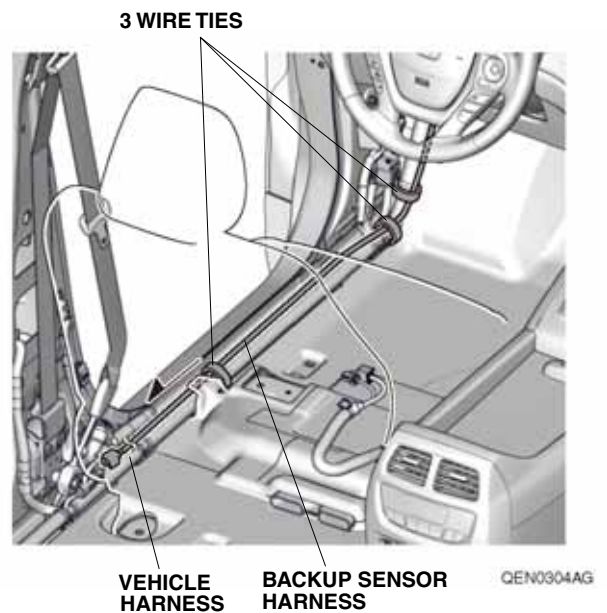

40. Secure the backup sensor harness to the vehicle harness with three wire ties.

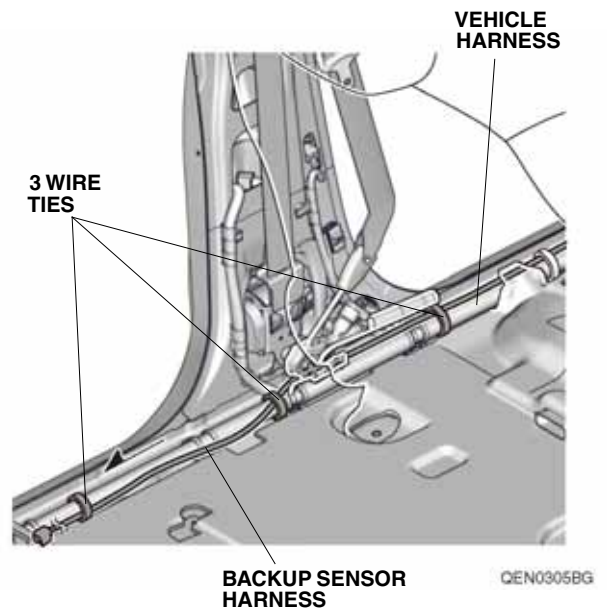

41. Fold back the floor carpet as shown.

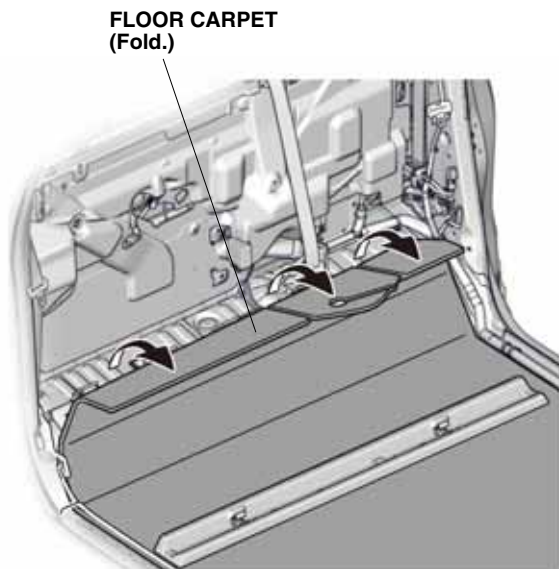

QF11505BG

42. Secure the backup sensor harness to the vehicle harness with three wire ties.

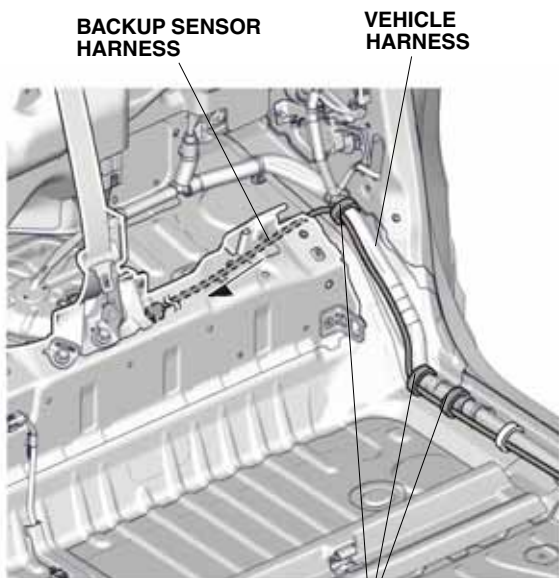

QEN0306CG

43. Secure the backup sensor harness to the vehicle panel with one wire tie with clip A and two wire ties with clip B.

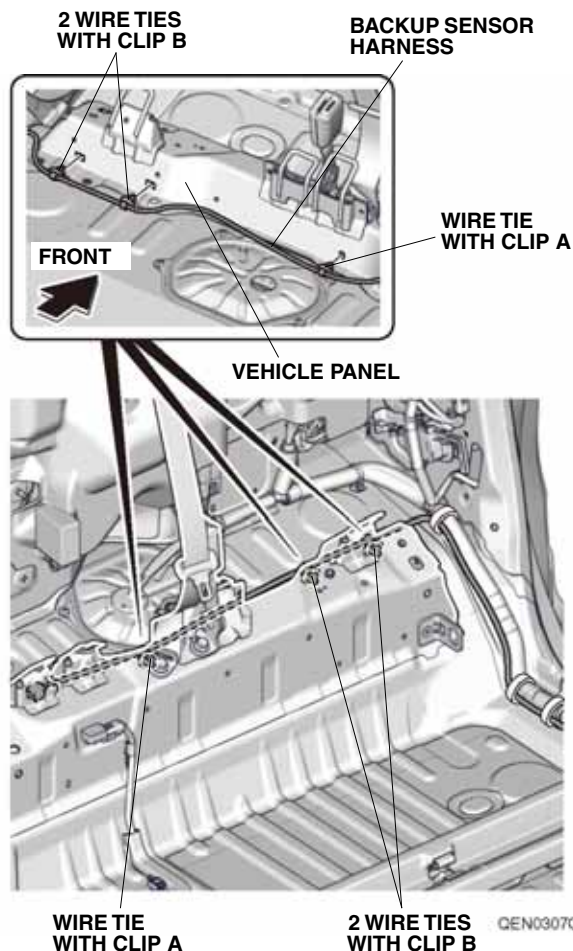

44. Secure the backup sensor harness to the vehicle panel with three wire ties with clip B.

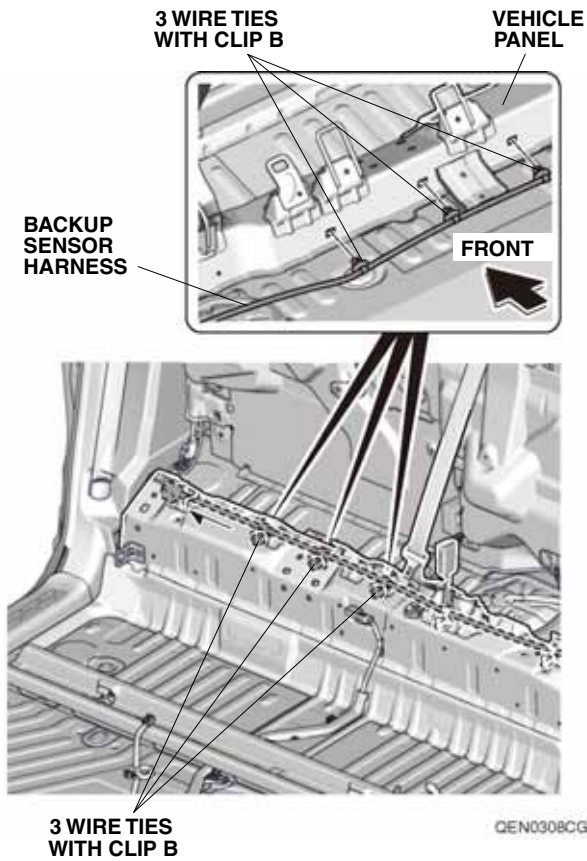

46. Using a utility knife, cut off the rear trim panel insulator as shown.

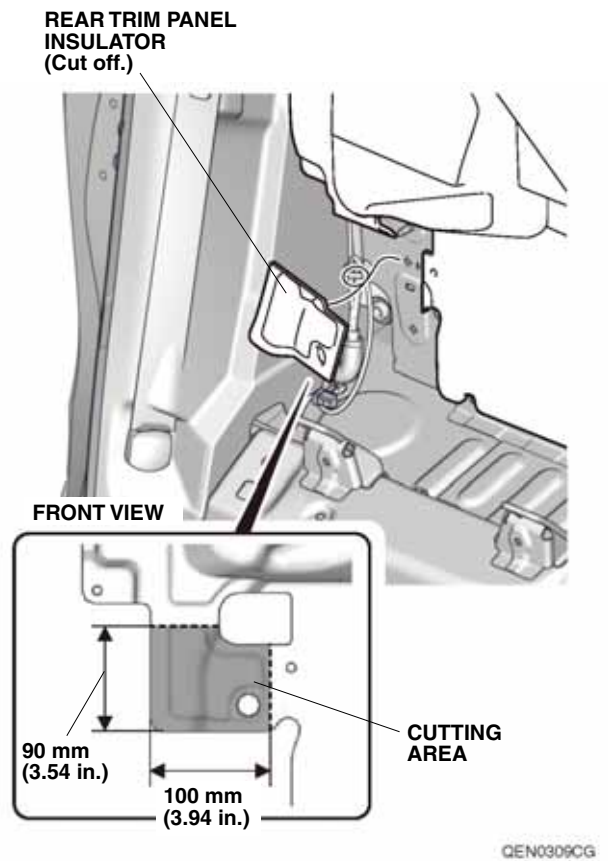

45. Remove the clip from the rear trim panel insulator.

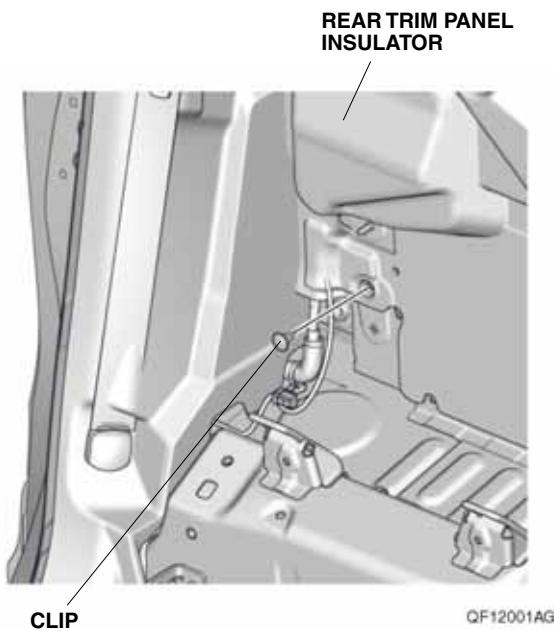

47. Install the control unit bracket on the control unit.

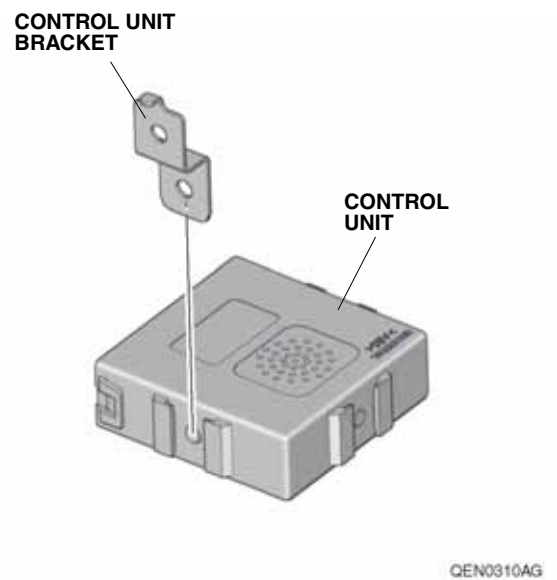



- Insert the control unit bracket into the hole in the vehicle panel. Secure the control unit bracket and backup sensor harness ground terminal with one ground bolt.

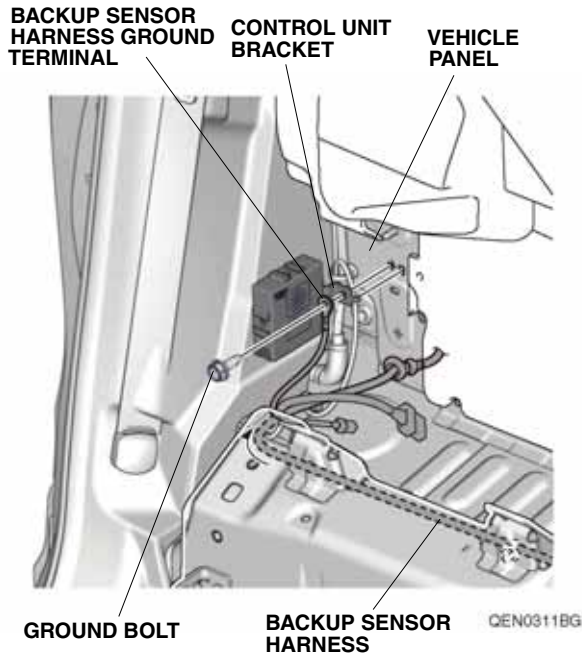

- Plug the backup sensor harness 14-pin connector into the control unit.

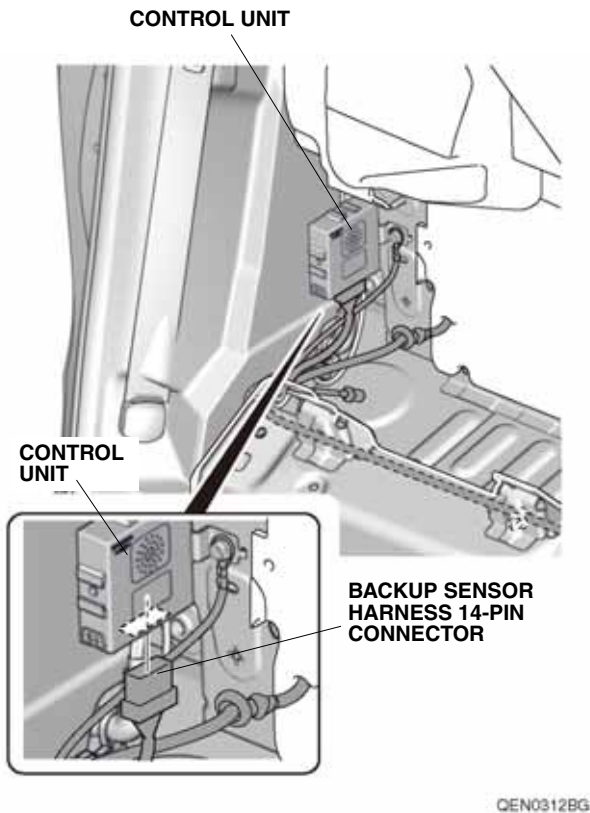

- Using isopropyl alcohol on a shop towel, thoroughly clean the control unit where the buzzer will attach.

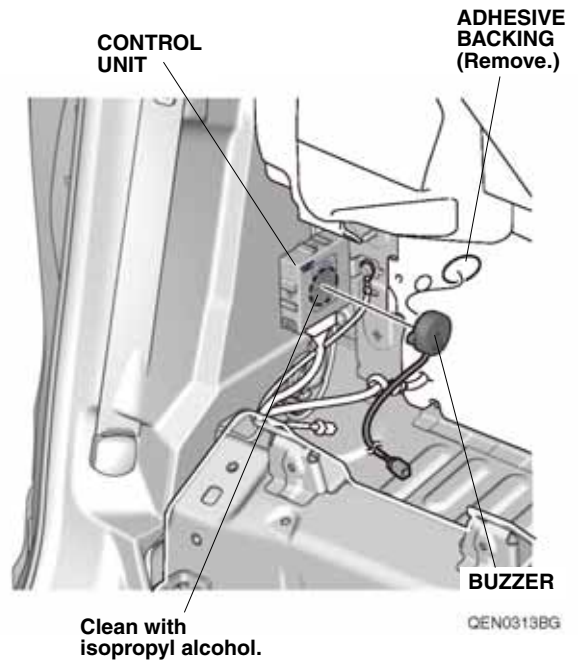

- Remove the adhesive backing from the buzzer and attach the buzzer to the control unit as shown.
- Plug the backup sensor harness 2-pin connector into the buzzer 2-pin connector.

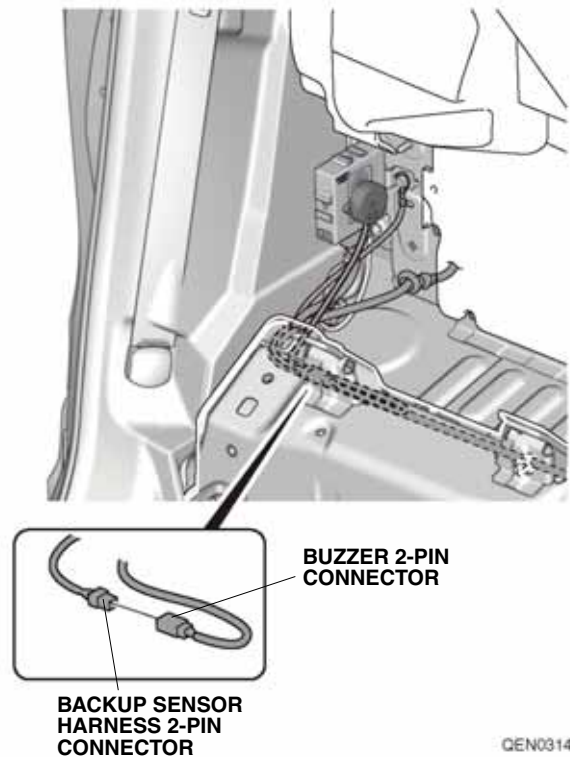

53. Bundle up the excess buzzer harness and secure the buzzer harness and backup sensor harness to the vehicle panel with one wire tie with clip A and one wire tie with clip B.

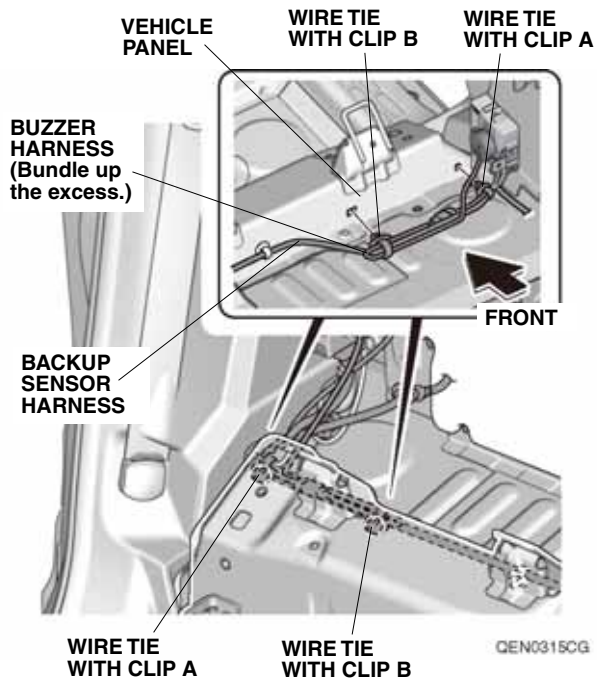

54. Remove the vehicle grommet. Route the backup sensor harness through the vehicle grommet hole. Install the floor carpet.

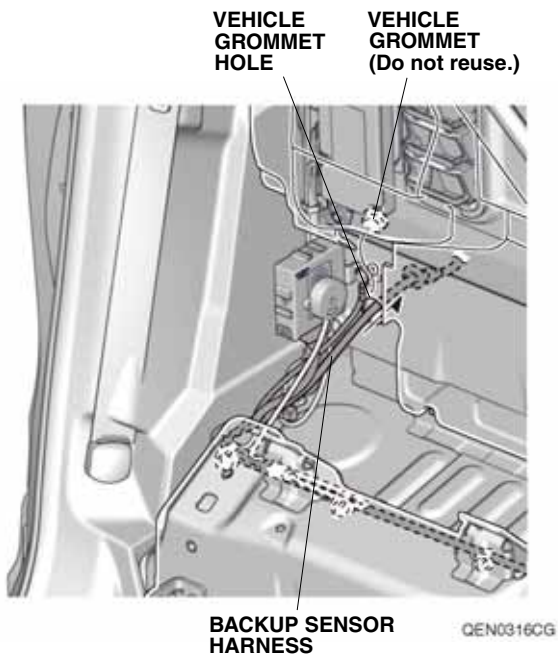

55. Install the backup sensor harness grommet into the vehicle grommet hole.

NOTE:

- Install the backup sensor harness by holding the grommet.
- Make sure to check that the grommet is secured properly.

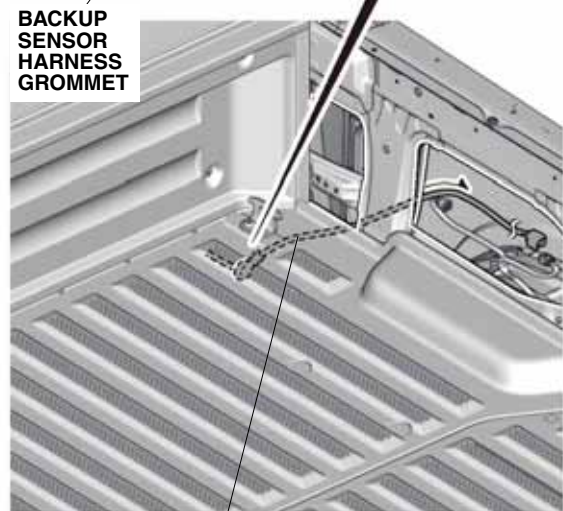
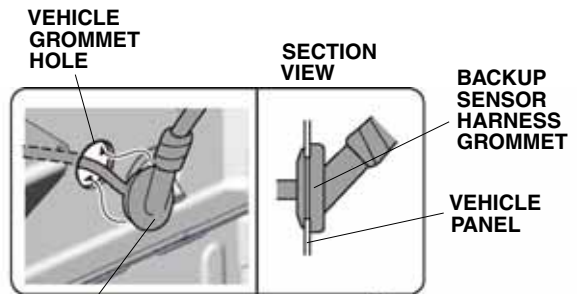

BACKUP SENSOR HARNESS

QEN0317BG

56. Secure the backup sensor harness to the vehicle panel with one wire tie with clip A.

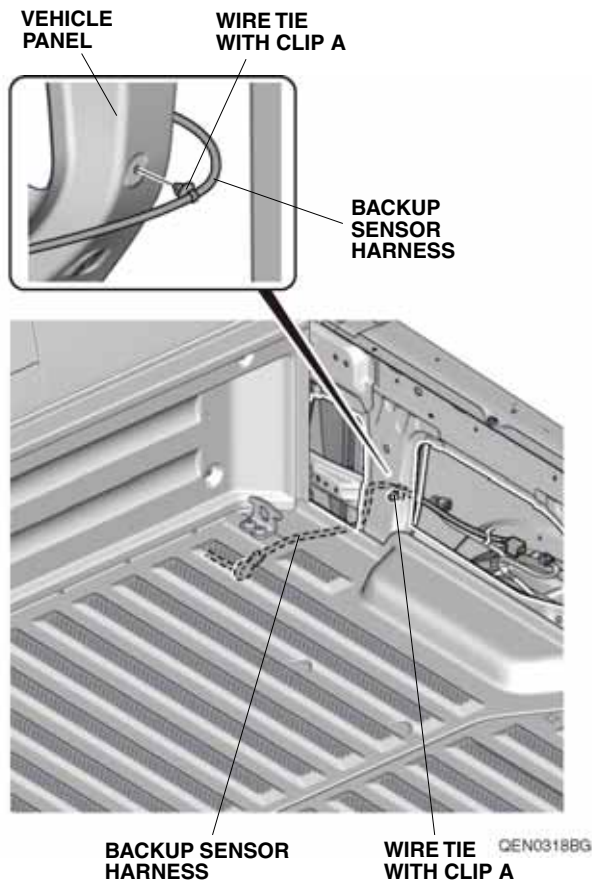

57. Using isopropyl alcohol on a shop towel, thoroughly clean the vehicle panel where the aluminum tape will attach.

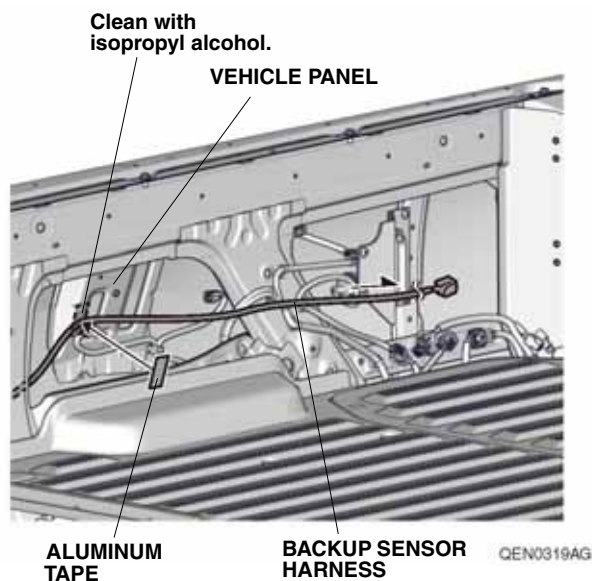

58. Secure the backup sensor harness to the vehicle panel with one aluminum tape as shown.

59. Secure the backup sensor harness to the vehicle panel and vehicle harness with one wire tie with clip A and three wire ties.

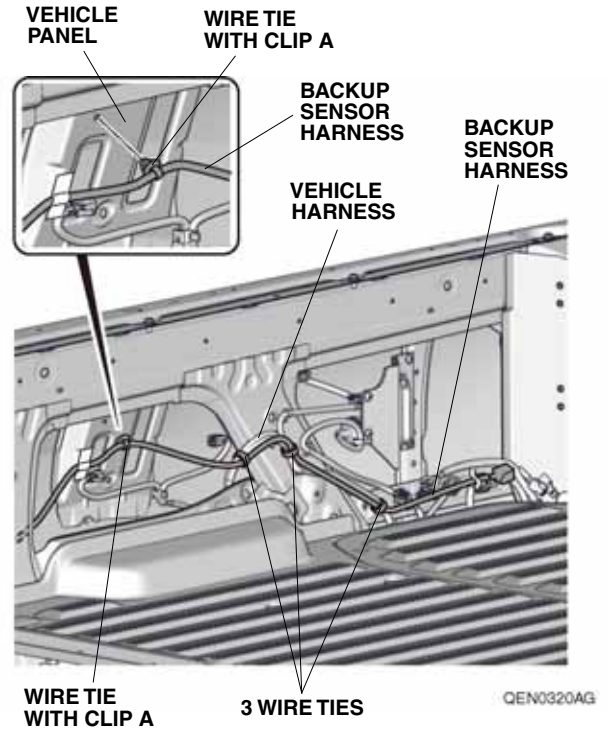

60. Secure the backup sensor harness to the vehicle harness with two wire ties.

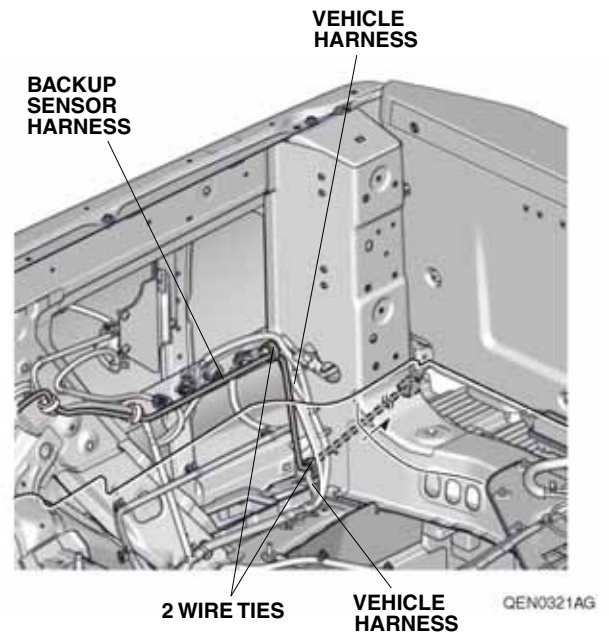

61. Secure the backup sensor harness to the vehicle harness with three wire ties.

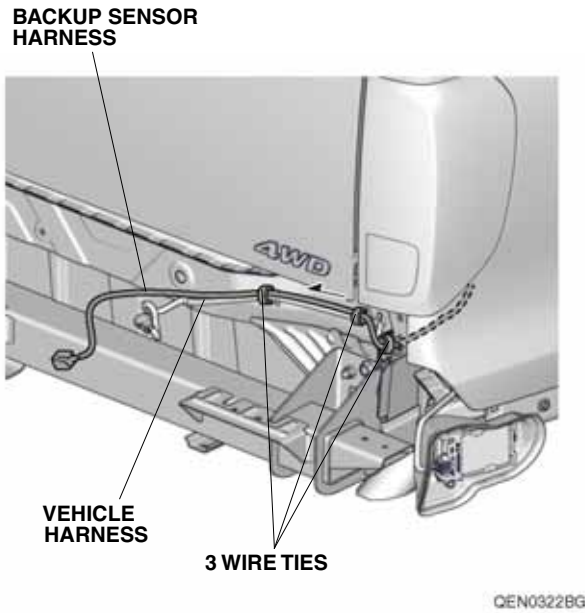

62. Secure the backup sensor harness to the vehicle harness with one wire tie.

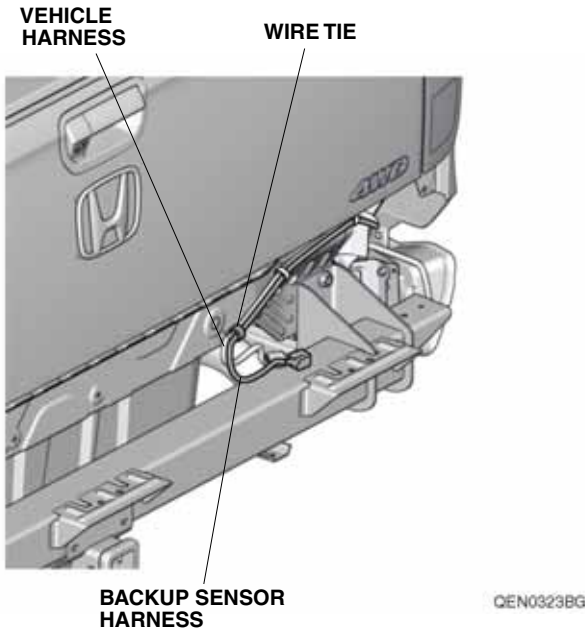

63. Using a utility knife, cut off the right rear step support as shown. Install the right rear step support.

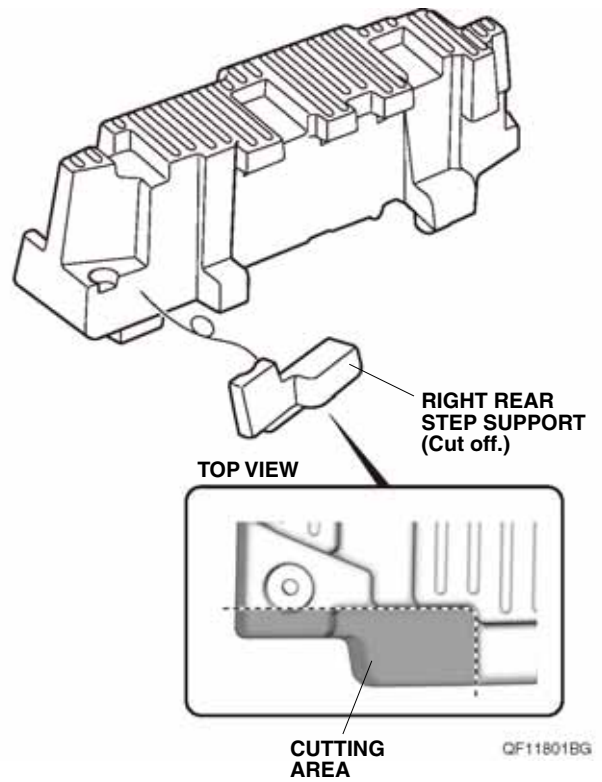

64. Repeat step 63 on the left side of the vehicle.

65. Mark the inside of the rear bumper:

- Locate the four scribe marks on the inside of the rear bumper at the left corner and right corner.
- Using a pushpin, pierce the rear bumper at the bottom and center of the two scribe marks.  
NOTE: There are several markings on the inside of the rear bumper. Before piercing the rear bumper, verify you have the correct locations.  
NOTE: Make sure to pierce perpendicular to the rear bumper.

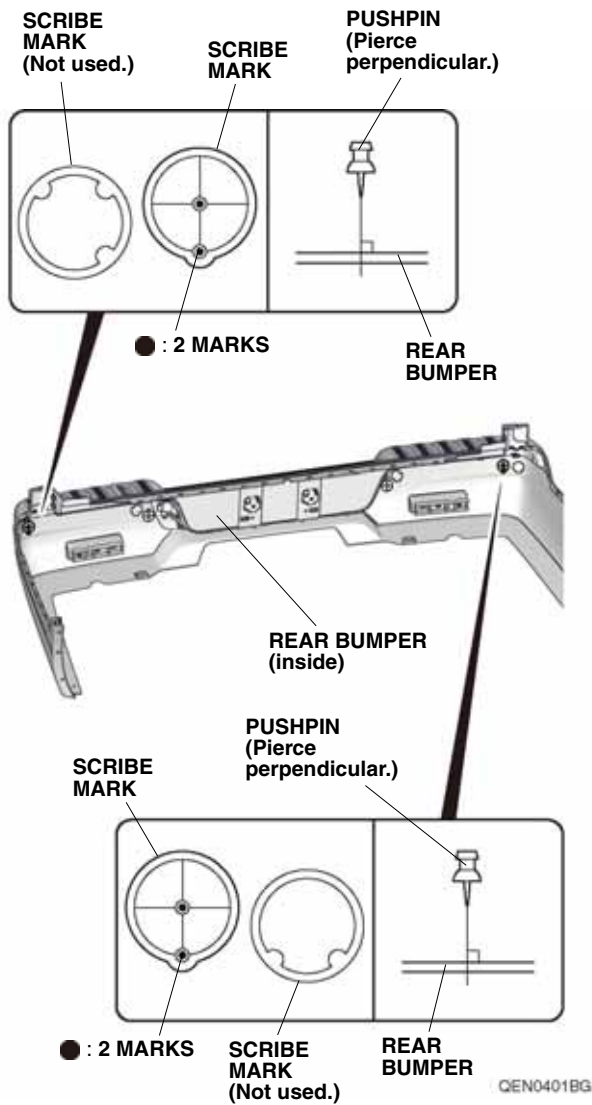

66. Mark the inside of the rear bumper:

- Locate the four scribe marks on the inside of the rear bumper at the left center and right center.
- Using a pushpin, pierce the rear bumper at the top and center of the two scribe marks.  
NOTE: There are several markings on the inside of the rear bumper. Before piercing the rear bumper, verify you have the correct locations.  
NOTE: Make sure to pierce perpendicular to the rear bumper.

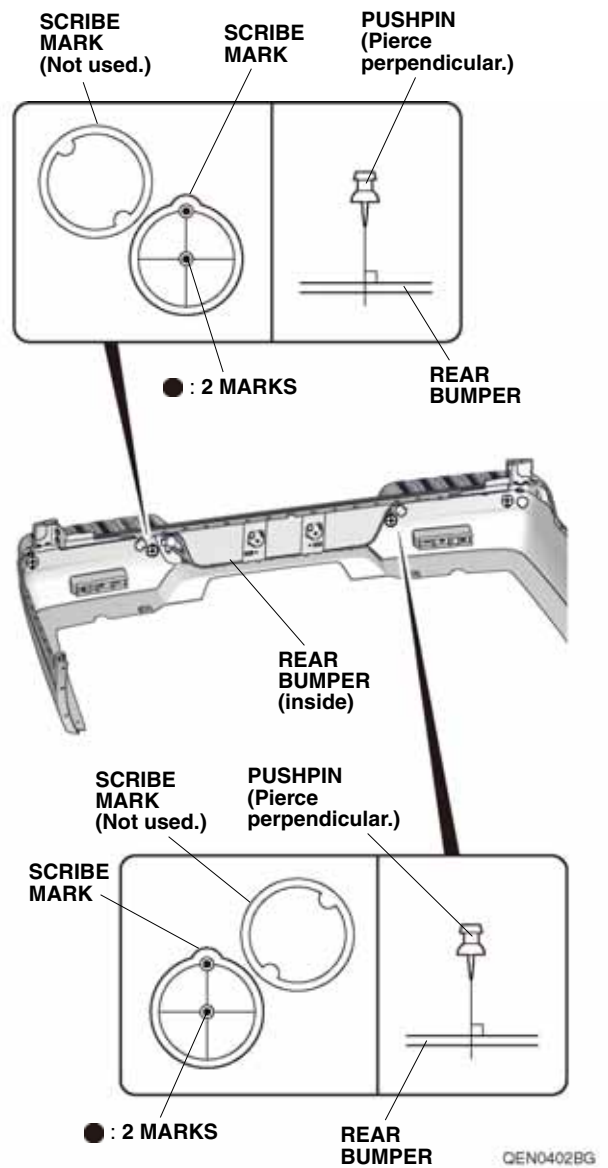

67. While wearing eye protection, drill the eight pierced marks with a 3 mm drill bit from the painted side of the rear bumper.
- NOTE: Make sure to drill perpendicular to the rear bumper.

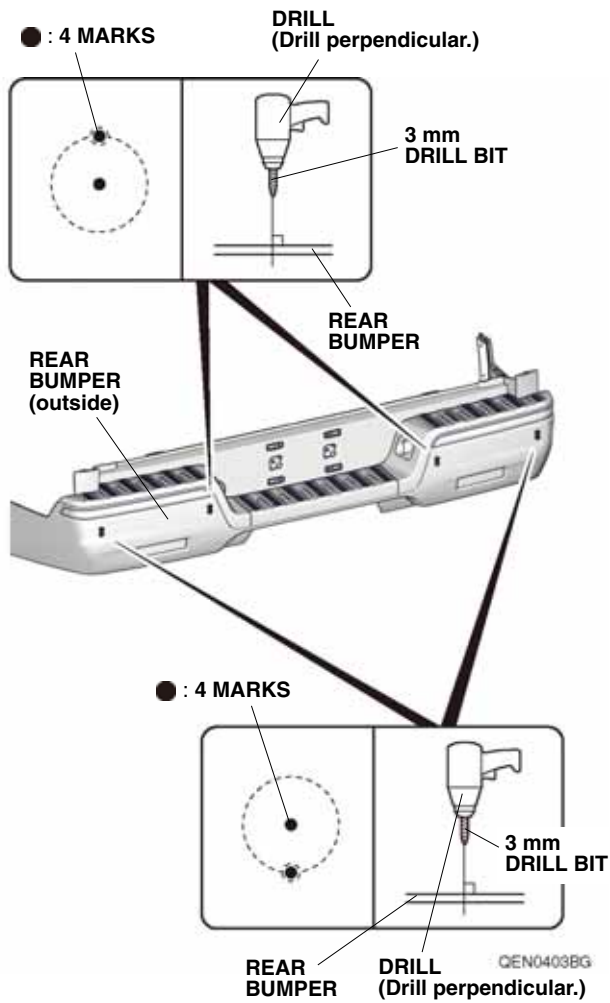

68. While wearing eye protection and drilling from the painted side of the rear bumper, enlarge the two upper 3 mm outer holes to 24 mm using a 24 mm hole saw.
- NOTE: Make sure to drill perpendicular to the rear bumper. Remove any burrs.

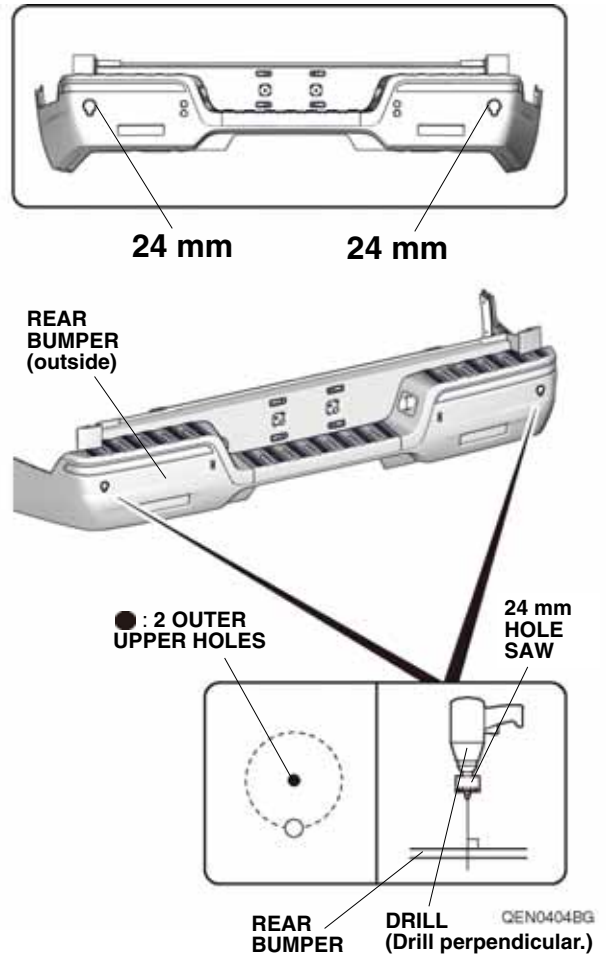

69. While wearing eye protection and drilling from the painted side of the rear bumper, enlarge the two lower 3 mm inner holes to 26 mm using a 26 mm hole saw.
- NOTE: Make sure to drill perpendicular to the rear bumper. Remove any burrs.

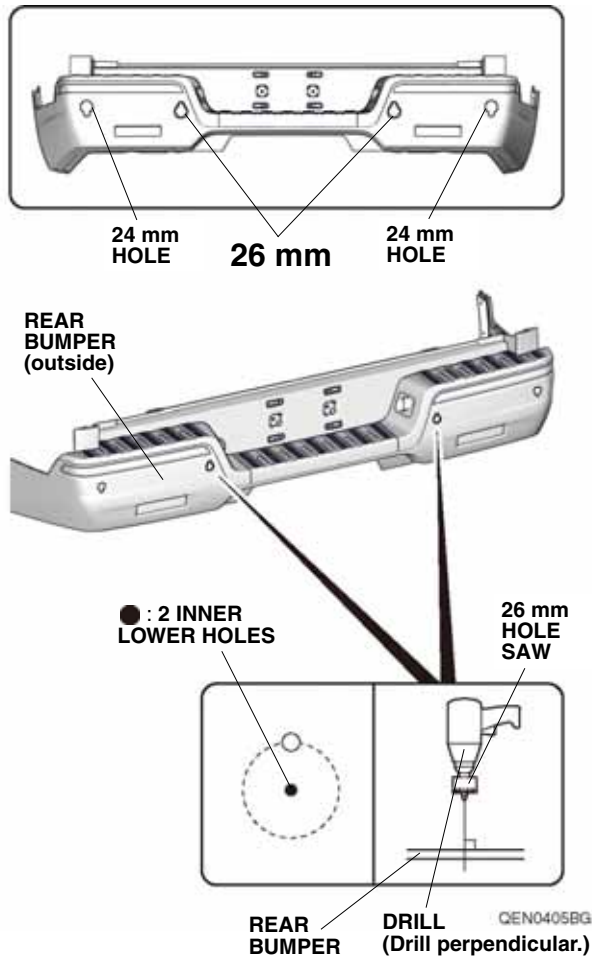

70. Insert the left corner sensor (white) and left center sensor (blue) into the rear bumper.
- NOTE: The left center sensor (blue) have the yellow dot label.

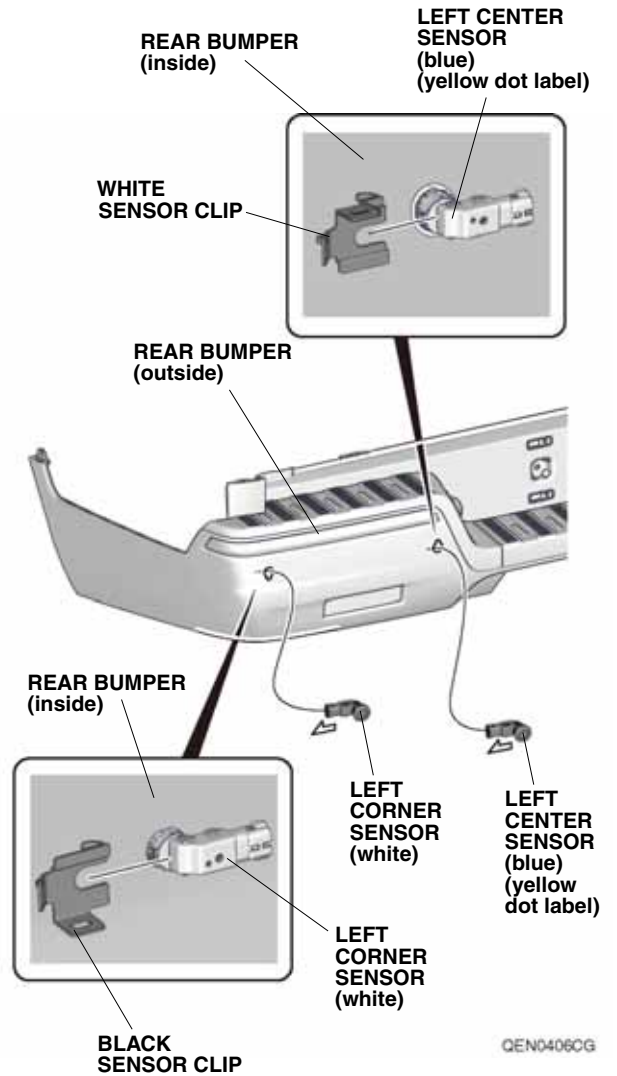

71. Secure the left corner sensor (white) and left center sensor (blue) with white sensor clip and black sensor clip as shown.

72. Insert the right center sensor (blue) and right center sensor (blue) into the rear bumper.  
NOTE: The right corner sensor (white) have the yellow dot label.

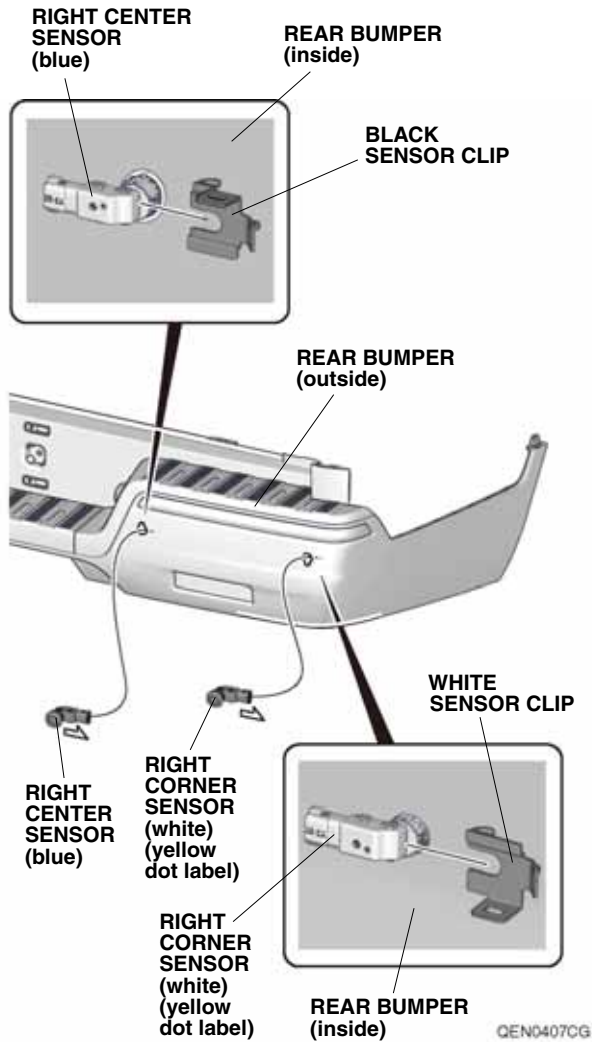

73. Secure the right corner sensor (white) and right center sensor (blue) with white sensor clip and black sensor clip as shown.

74. Plug the four subharness 2-pin connectors into the two center sensors (blue) and the two corner sensors (white).

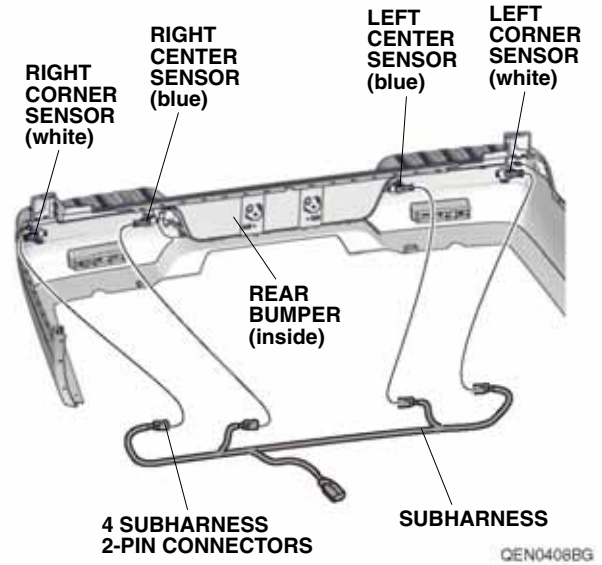

75. Secure the subharness to the four tabs on the rear bumper.

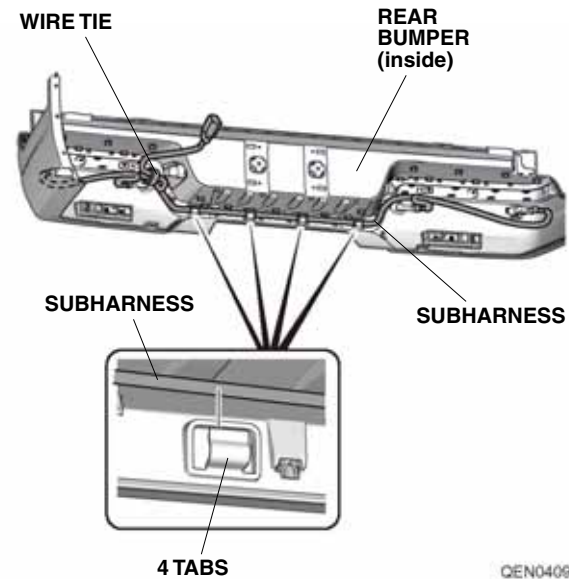

76. Secure the subharness to the subharness with one wire tie.



77. Secure the subharness to the rear bumper with four wire ties with clip C.

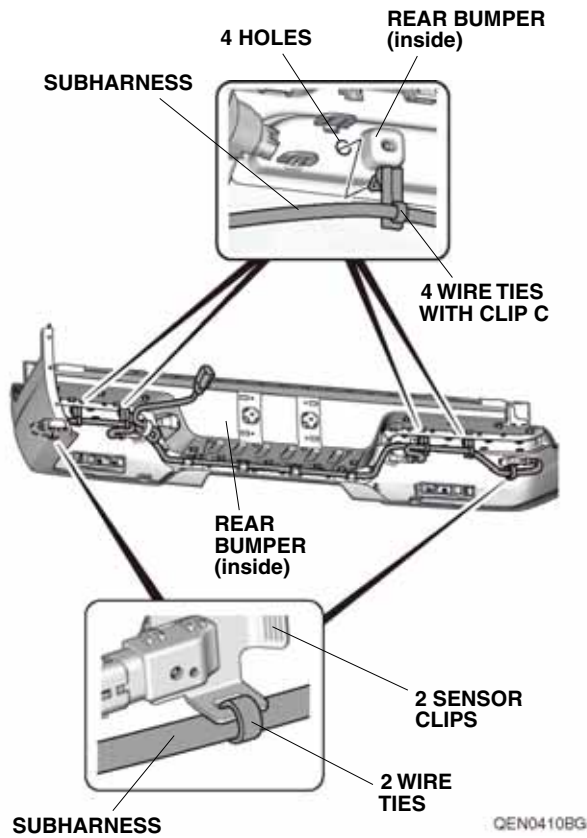

78. Secure the subharness to the two sensor clips with two wire ties.

79. With the help of an assistant, bring the rear bumper close to the vehicle, and plug the backup sensor harness 8-pin connector into the subharness 8-pin connector. Install the rear bumper.

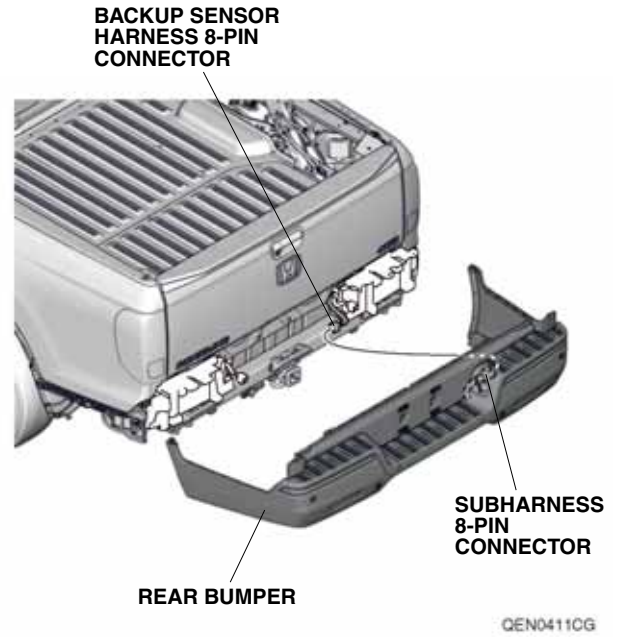

80. Using a pushpin, pierce the driver's dashboard lower cover as shown.

NOTE: Make sure to pierce the mark perpendicular to the driver's dashboard lower cover.

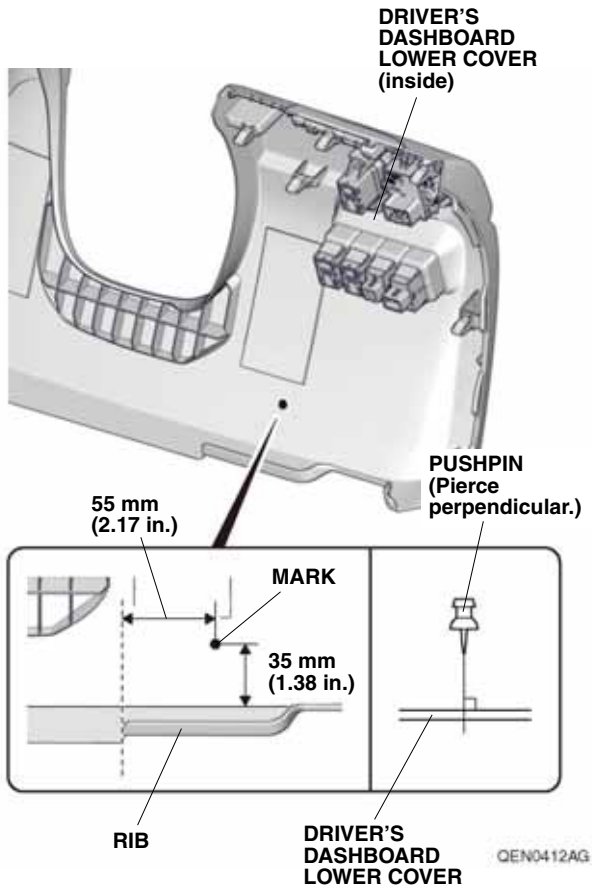

81. While wearing eye protection, drill the pierced mark on the driver's lower cover with a 3 mm drill bit.

NOTE: Make sure to drill perpendicular to the driver's dashboard lower cover.

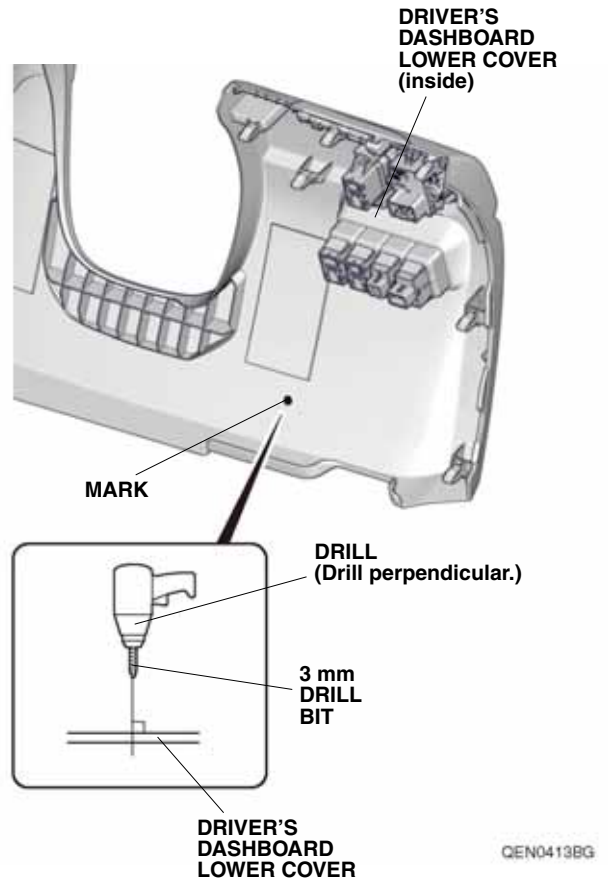

82. While wearing eye protection, enlarge the 3 mm hole to 26 mm using a 26 mm hole saw. Remove any burrs.  
 NOTE: Make sure to drill perpendicular to the driver's dashboard lower cover.

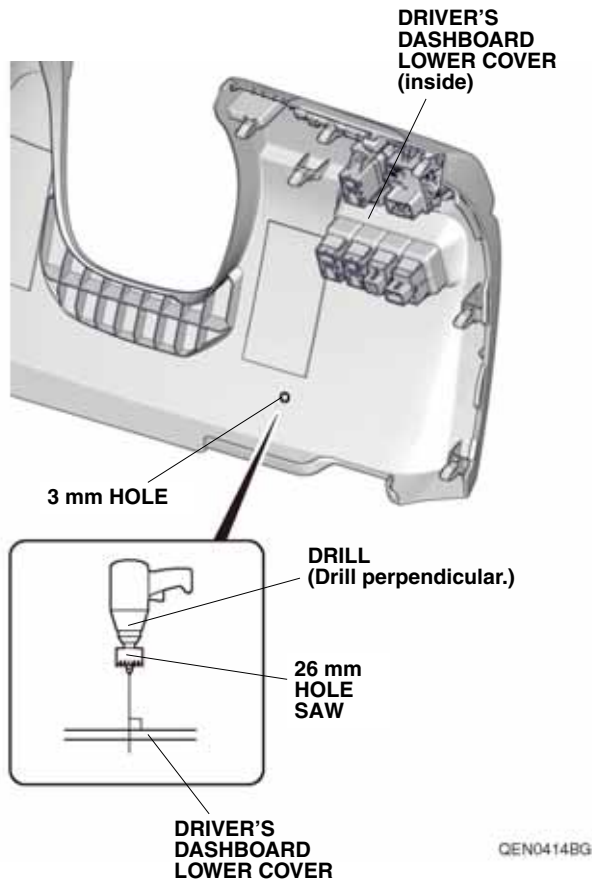

83. Install the switch into the 26 mm hole in the driver's dashboard lower cover.  
 NOTE: Make sure to install the switch in the correct orientation.

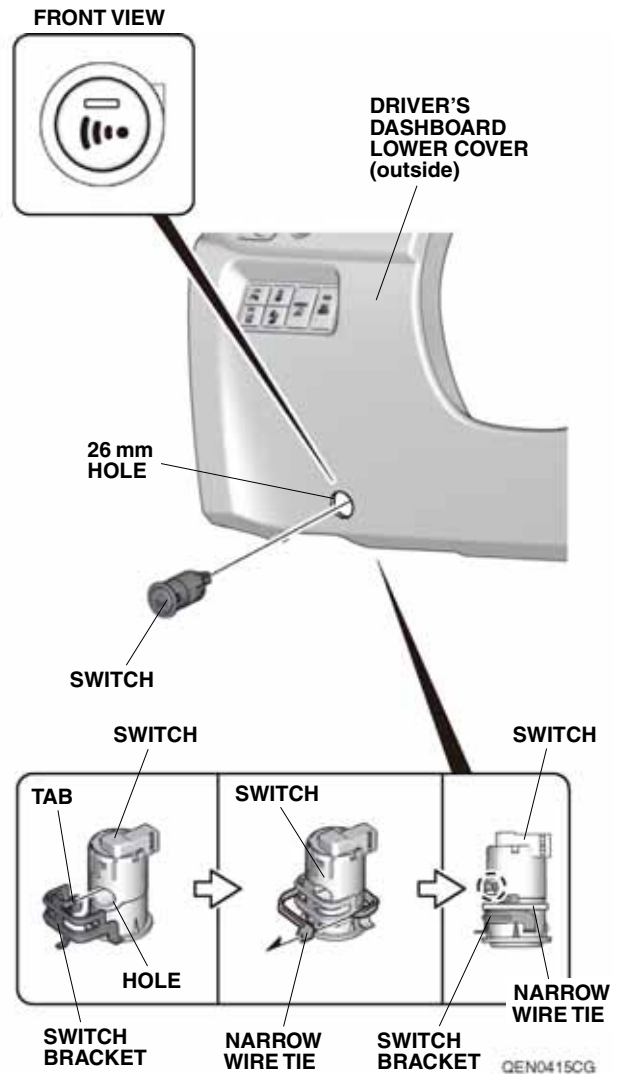

84. Align the tab on the switch bracket with the hole on the switch and secure the switch bracket to the switch with one narrow wire tie.  
 NOTE: Firmly press the switch bracket against the driver's lower cover and make sure that there is no clearance between the switch and the driver's lower cover.

85. Bring the driver's lower cover into position. Plug the backup sensor harness 3-pin connector into the switch.

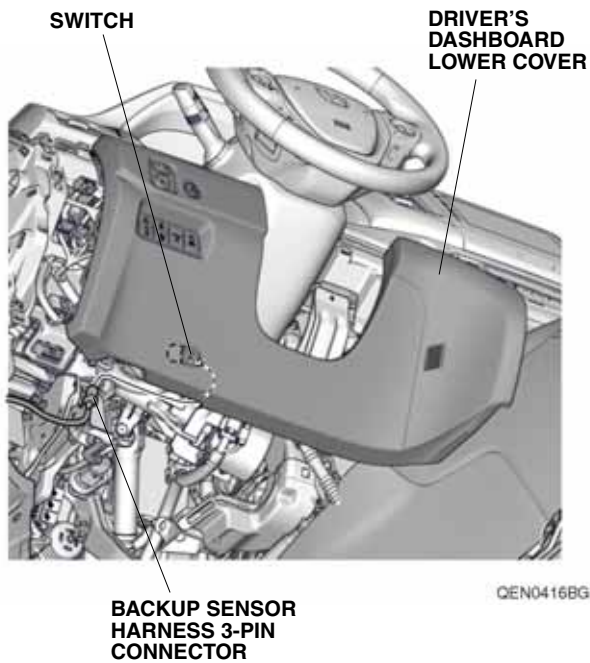

86. Install the driver's dashboard lower cover.

87. Install the left C-pillar lower trim. Remove the vehicle clip, and install the new clip into the left C-pillar upper trim.

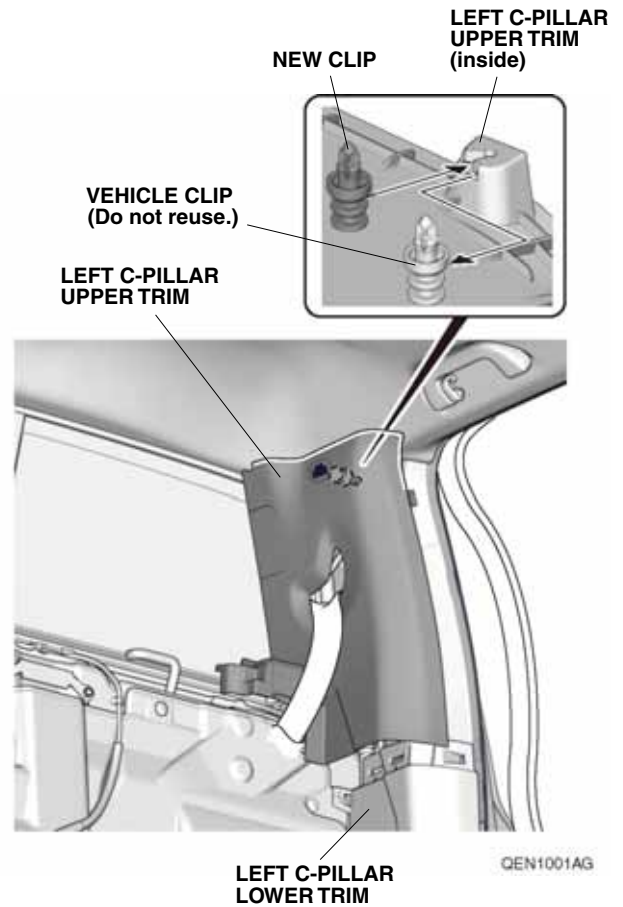

88. Check the overlap between the headliner and the left C-pillar upper trim.  
NOTE: Check and adjust the overlap as described in the service information.
89. Install the left C-pillar upper trim.  
NOTE: Make sure the side curtain airbag is not tucked under the clip. Do not push the left C-pillar upper trim excessively.

90. Check that all wire harnesses are routed properly and all connectors are plugged in.
91. Install all removed parts except for the front bulkhead cover and the intake air tube.
92. Connect the negative cable to the battery.
93. Install the front bulkhead cover and the intake air tube.
94. Press and hold the audio unit power button for 2 seconds to restore the audio and navi (if equipped) system functions.
95. Set the clock on vehicles without navigation.

### **Check the Operation of the Backup Sensors**

96. Check that the backup sensors work properly as described in the accessory user's information manual supplied with the backup sensor kit.

### **Adjust the Volume Control**

The factory setting is maximum volume. After confirming the operation, turn the volume control knob to the appropriate level, using a small flat-tip screwdriver.

**NOTE:** Do not force the adjuster as it could damage the unit.

