

PARTS LIST

Engine block heater



Aluminum washer



Heater harness

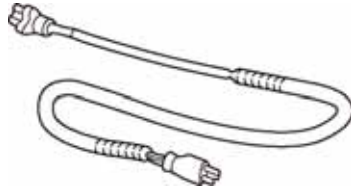

Protective cap



12 Black wire ties
(1 Not used)



7 Wire ties with clip
(6 Not used)



5 Natural wire ties
(2 Not used)



TOOLS AND SUPPLIES REQUIRED

Phillips screwdriver

Flat-tip screwdriver

Ratchet

10 mm, 19 mm, and 24 mm Sockets

10 mm Open end wrench

Torque wrench

Diagonal cutters

Hacksaw

File

Heavy gloves

Drain pan

Tape measure

White marker

Coolant (Honda All Season Antifreeze/Coolant Type 2)

Blanket

Fender cover

Masking tape

Shop towel

The following tool is available through the Honda Tool and Equipment Program. On the iN, click on: Service > Service Bay > Tool and Equipment Program, then enter the number under "Search". Or, call 888-424-6857.

- Trim Tool Set (T/N SOJATP2014)

Illustration of the Engine Block Heater in the Vehicle

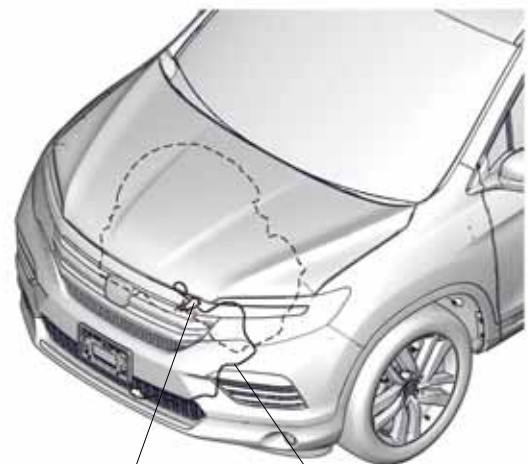

ENGINE BLOCK HEATER

HEATER HARNESS

QD00801B8

INSTALLATION

Customer Information: The information in this installation instruction is intended for use only by skilled technicians who have the proper tools, equipment, and training to correctly and safely add equipment to your vehicle. These procedures should not be attempted by “do-it-yourselfers.”

NOTE:

- Always use, Honda All Season Antifreeze/Coolant Type 2. Using a non-Honda coolant can result in corrosion, causing the cooling system to malfunction or fail.
 - To avoid burning out the element, do not operate the engine block heater until it is installed in the vehicle and you have added coolant.
1. Allow the engine and all cooling system components to cool down.
 2. Wrap a shop towel around the hood latch.

HOOD LATCH
(Wrap with a shop towel.)

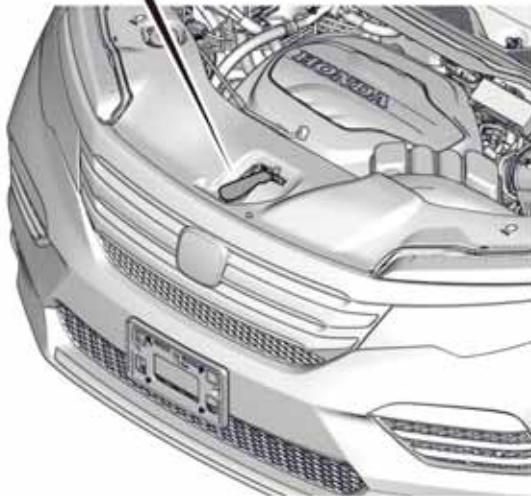
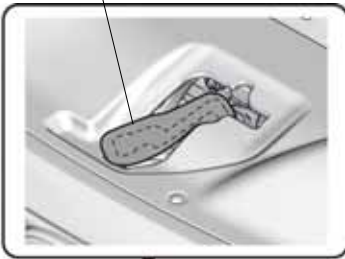

QDN1301AA

- Remove the front bulkhead cover.

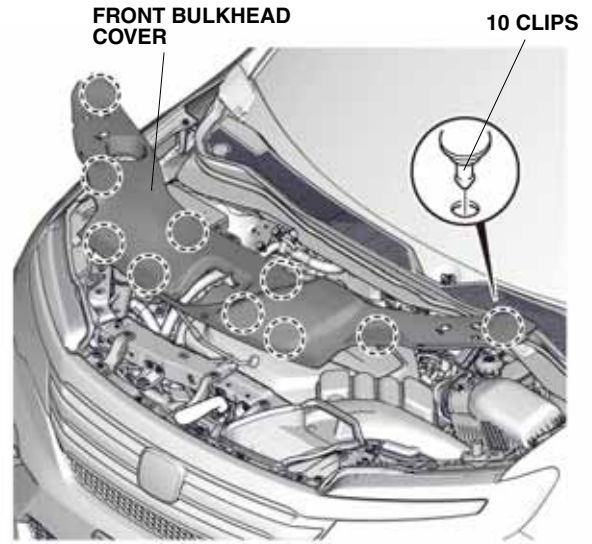

QDN1302AA

- Remove the intake air tube.
- Disconnect the negative cable from the battery.

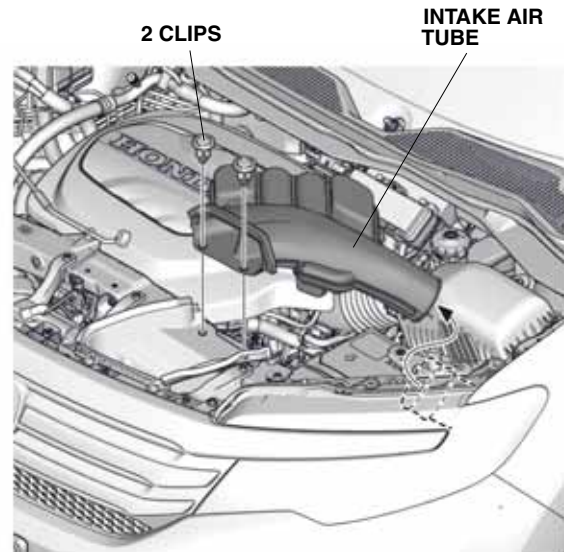

QDN1303AA

- Remove the three self-tapping screws from the left front wheel arch protector.

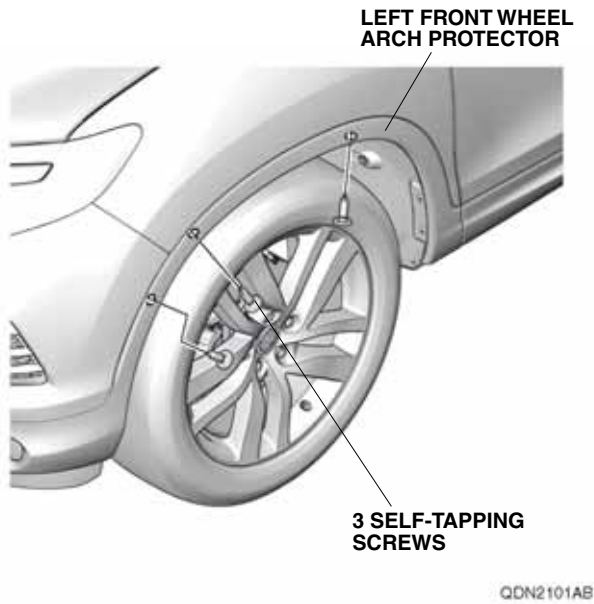

- Remove the left front wheel arch protector.

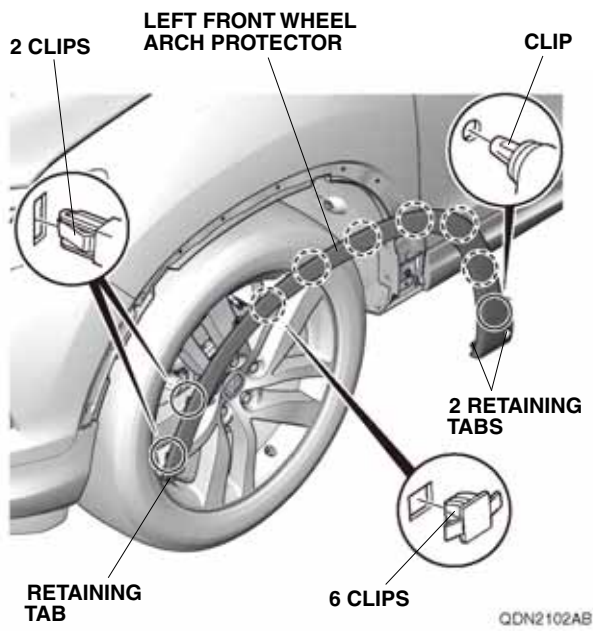

- Repeat steps 3 and 4 on the right side of the vehicle.

- Remove the front bumper:
 - Remove the intake air guide.

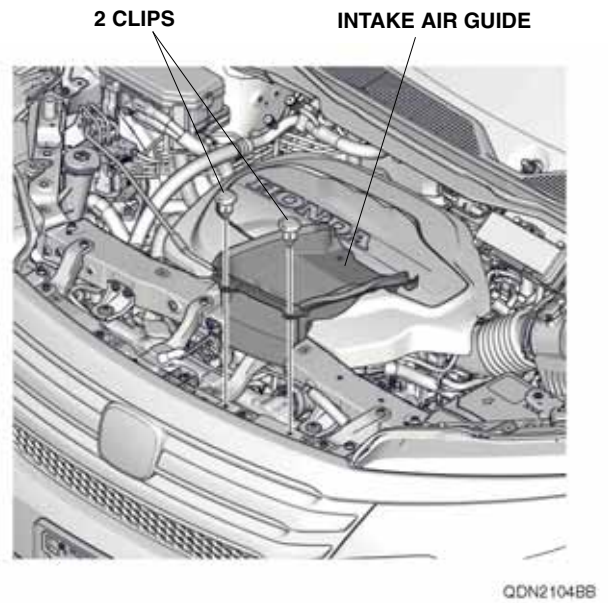

- Remove the front upper grille.

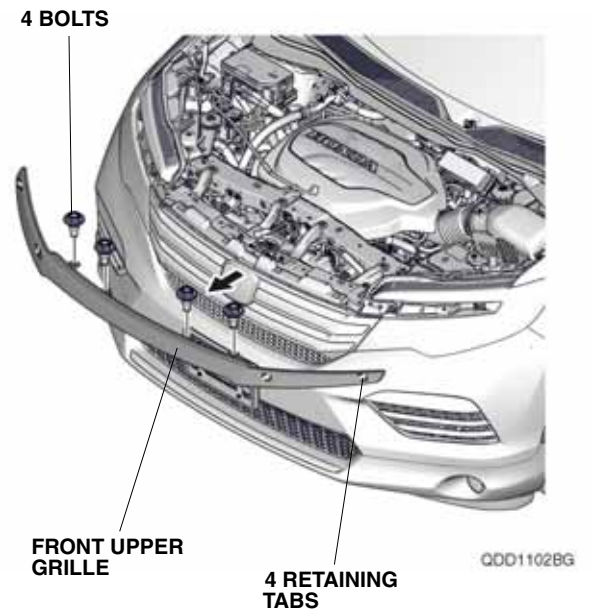

- Attach the masking tape to the areas shown on each side.

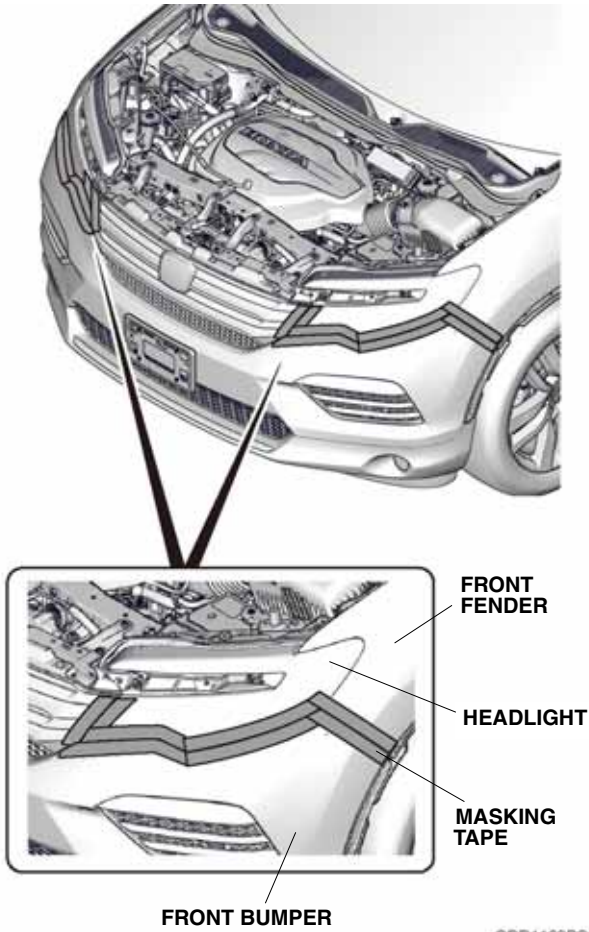

- Remove four self-tapping screws, eight clips, four washer-bolts, and four flange bolts.

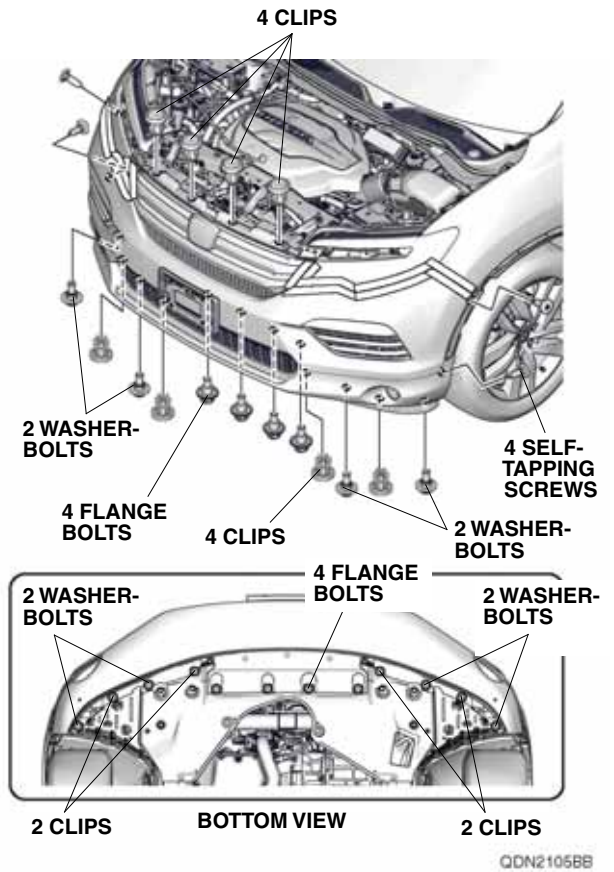

- With the help of an assistant, release three retaining tabs and seven hooks on each side.

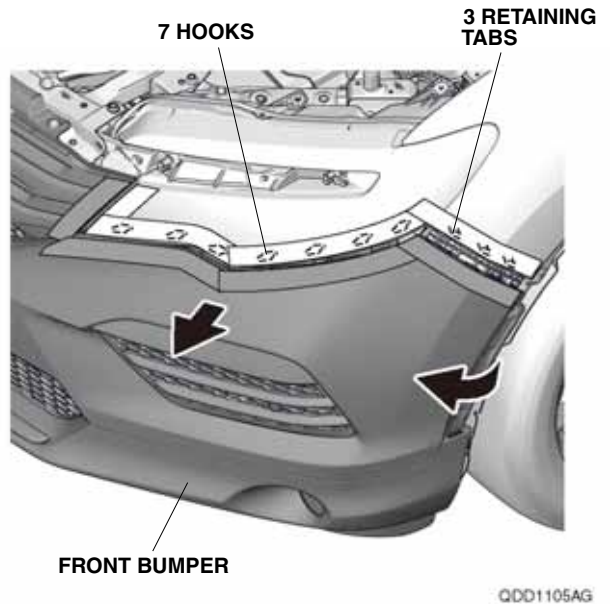

- Release the front grille.

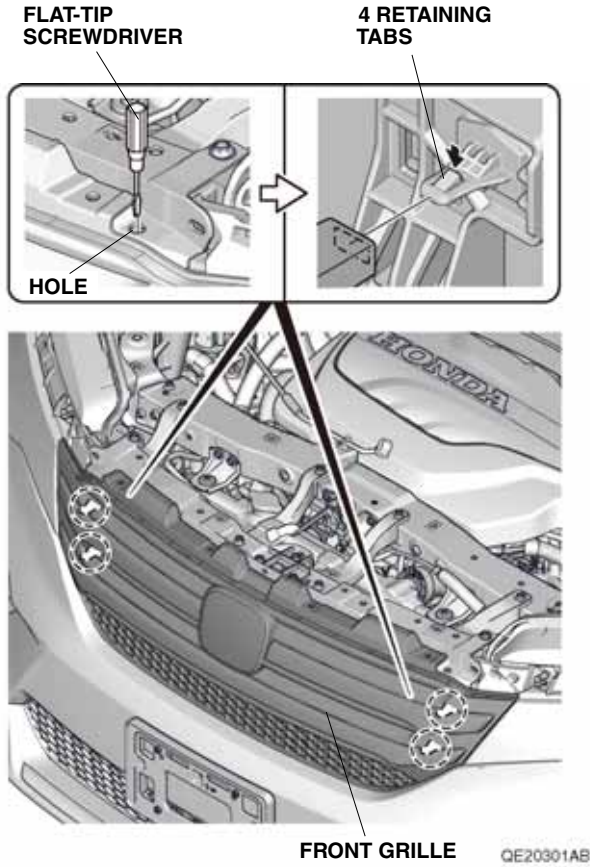

- With the help of an assistant, remove the front bumper, and unplug the vehicle connectors.
- Place the front bumper on a blanket to prevent damage.

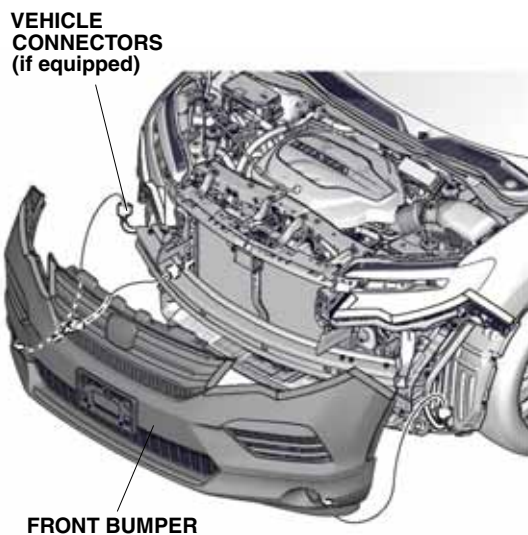

7. Open the positive cable cover, and disconnect the positive cable from the battery. Release the nut clip and vehicle clip on the negative cable.

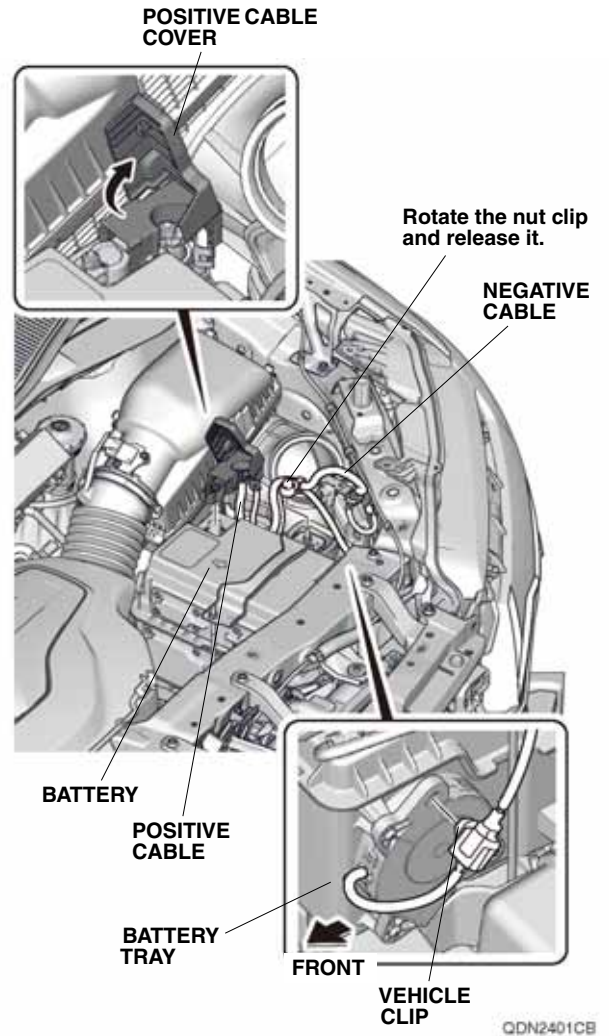

8. Remove the battery.

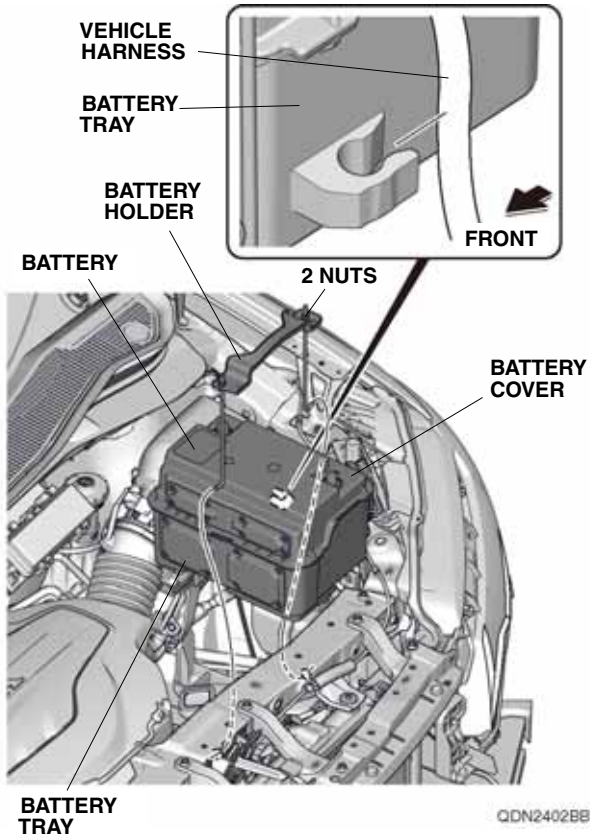

9. Place a clean drain pan under the radiator drain plug, then remove the drain plug from the bottom of the radiator to drain the coolant. Remove the radiator cap to increase the flow.

NOTICE: Radiator coolant will damage the paint. Quickly rinse any spilled coolant from the paint.

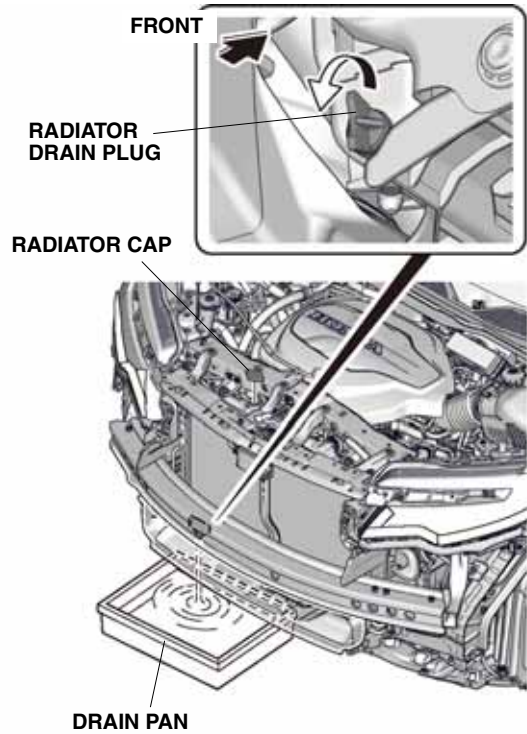

10. Drain the coolant completely, then reinstall the radiator cap.

- Get the heater harness. Using a tape measure, mark the heater harness at measurements **A**, **B**, and **C**.

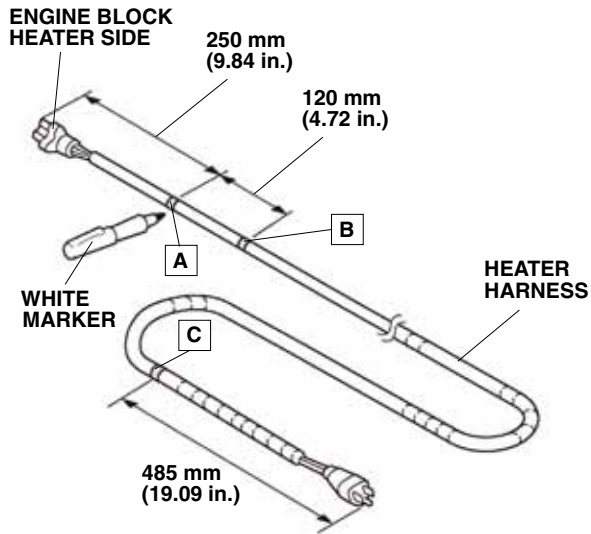

QE51909AB

- Install one wire tie with clip to the heater harness at point **A**.

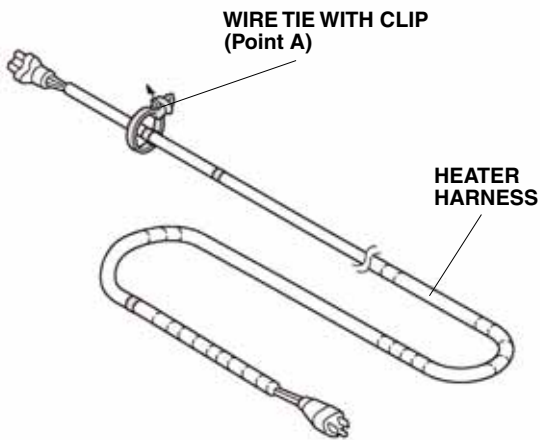

QE51910AB

- Locate and remove the drain bolt and washer. Coolant remaining in the engine jackets flows out of the hole when the drain bolt is removed. Retain the drain bolt; it will be used if the engine block heater is removed.

NOTE: Use a new washer if the drain bolt is reinstalled.

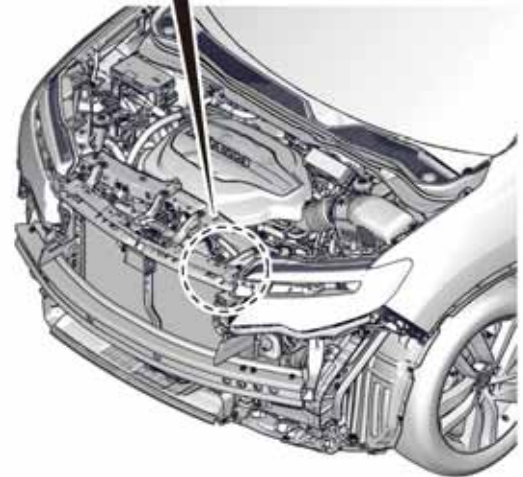
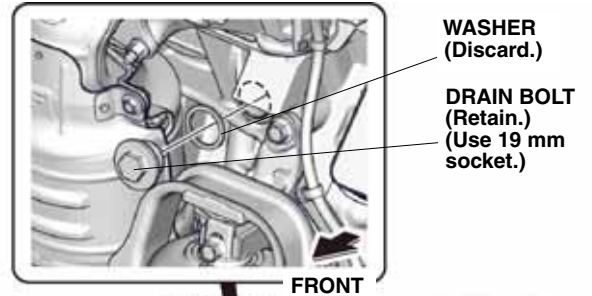

QDD0802BB

14. Install the engine block heater with the aluminum washer into the bolt hole using a 24 mm socket. Torque the engine block heater to 80 N·m (59 lbf·ft) (Use a 24 mm socket).

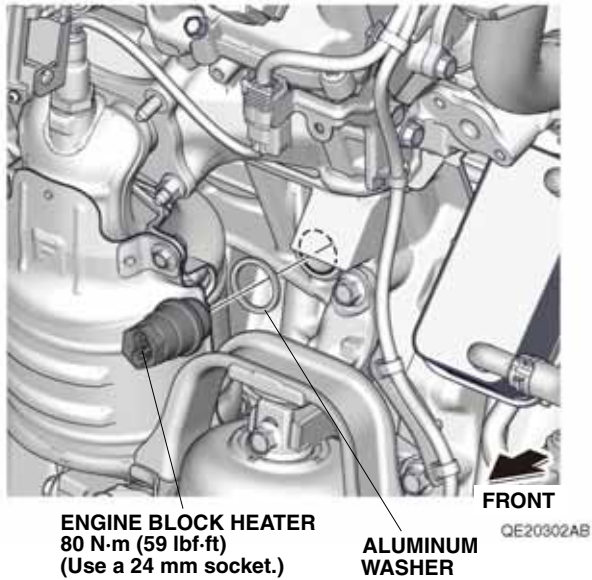

15. Plug the heater harness connector into the engine block heater. Make sure the heater harness connector is fully seated in the engine block heater.

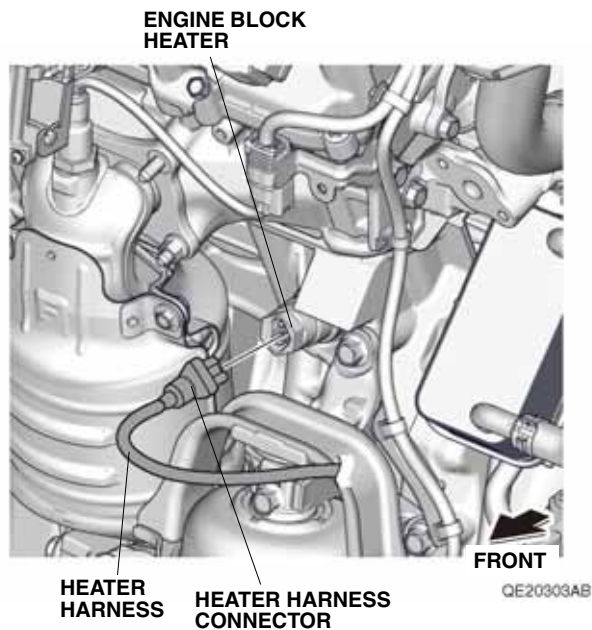

16. Route the heater harness in the direction shown, and secure the heater harness to the vehicle bracket with one wire tie with clip installed in step 12.

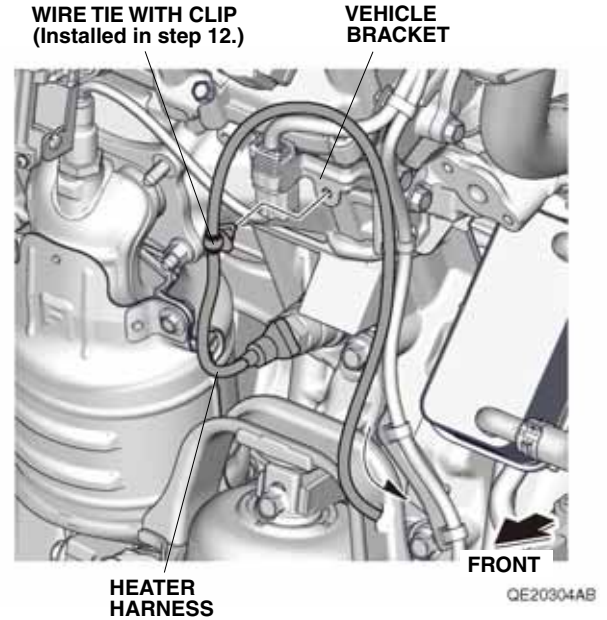

17. Route the heater harness toward the fan shroud, and secure the heater harness to the fan shroud rib with one natural wire tie at point B.

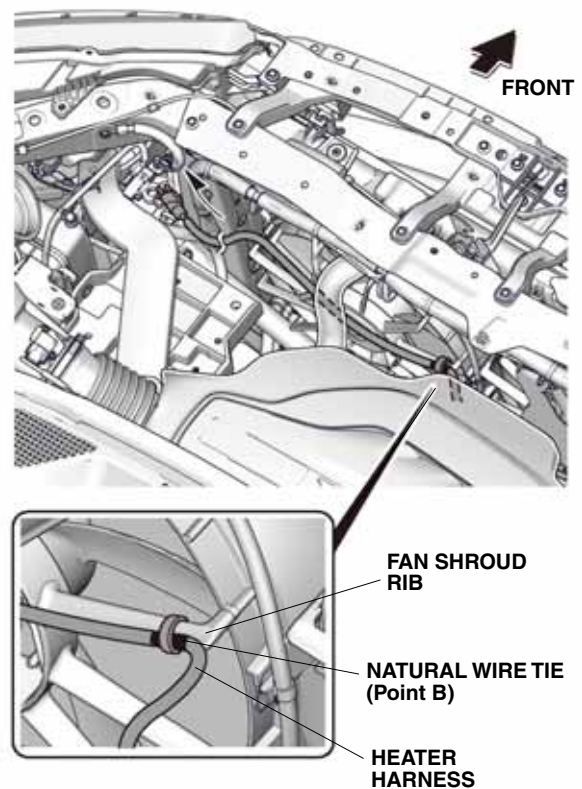

18. Route the heater harness along the fan shroud, and secure the heater harness to the fan shroud ribs with two natural wire ties and one black wire tie.

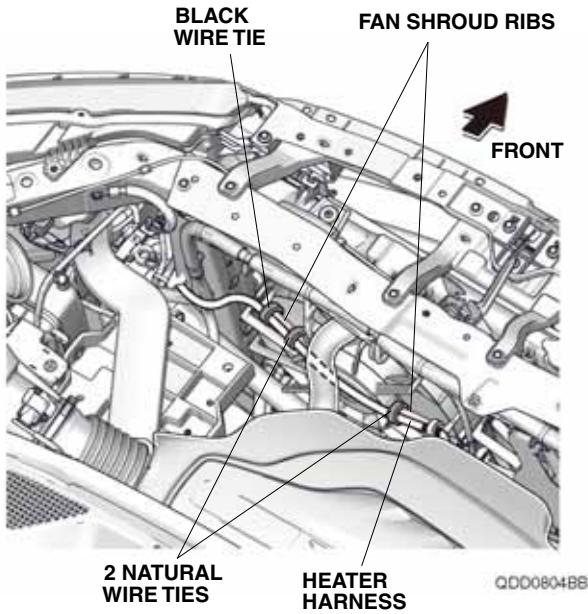

19. Route the heater harness through the front bulkhead, and secure the heater harness to the vehicle harness with three black wire ties.

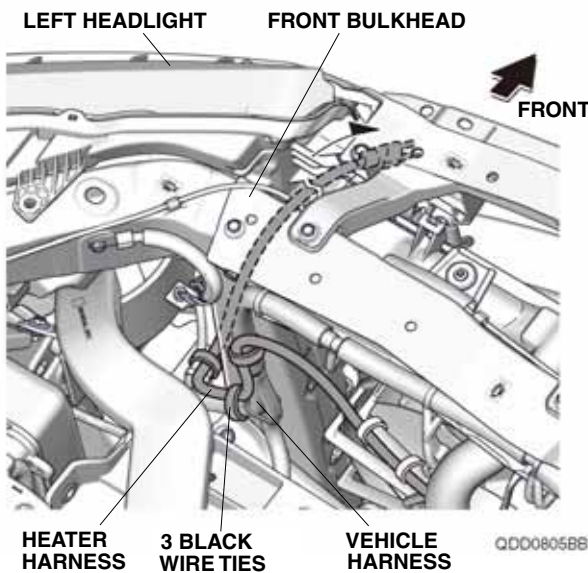

20. Route the heater harness down under the front bumper beam, and secure the heater harness to the left front air guide plate with one black wire tie at the point C.

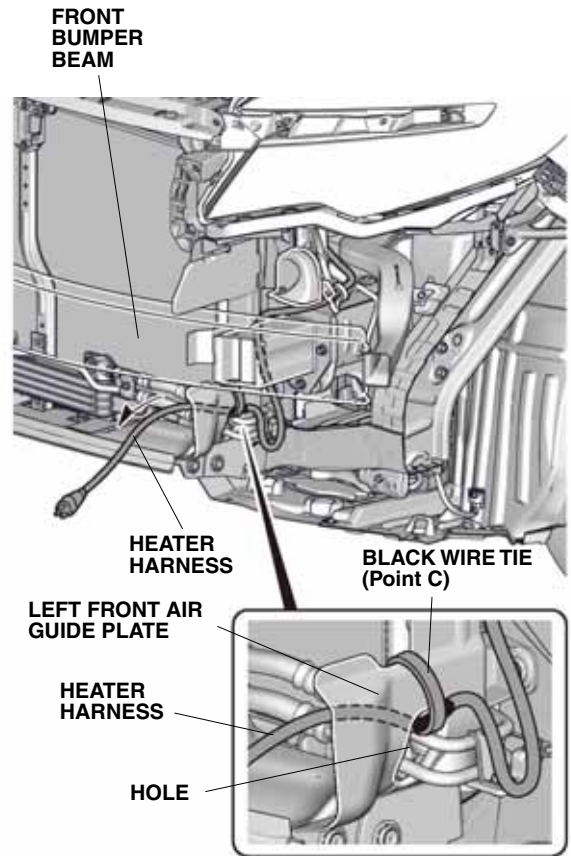

21. Connect two black wire ties together, and secure the heater harness to the left front bumper beam extension with the connected black wire ties.

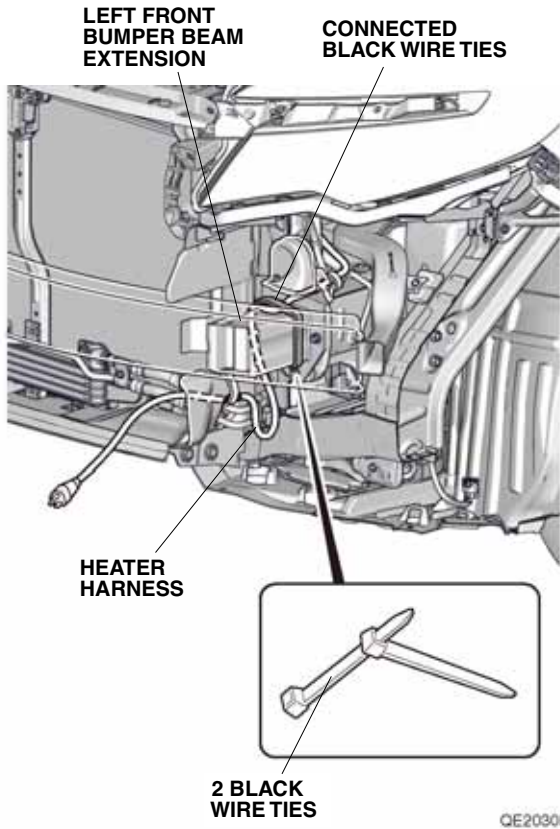

22. Bundle up the excess heater harness, and secure the heater harness with two black wire ties.

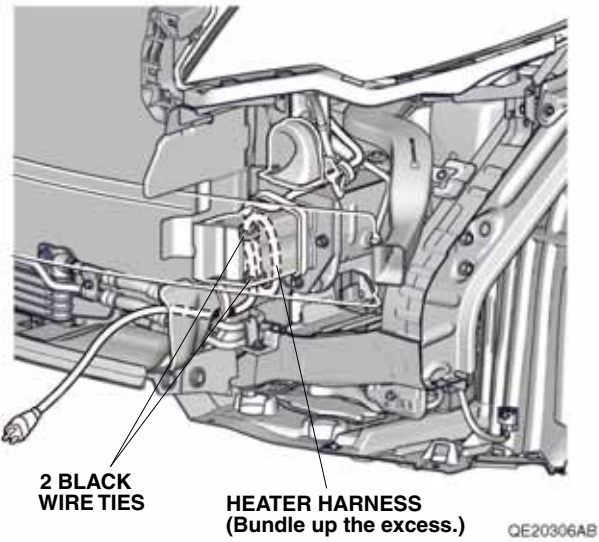

23. Using a hacksaw, cut the center lower grille as shown. Remove any burrs.

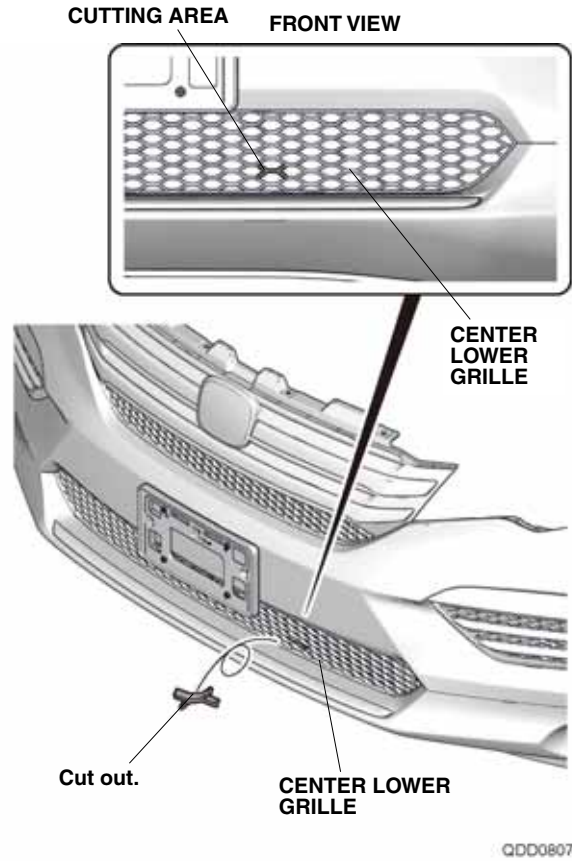

24. With the help of an assistant, bring the front bumper close to the vehicle. Route the heater harness through cutout on the center lower grille, then reinstall the front bumper.

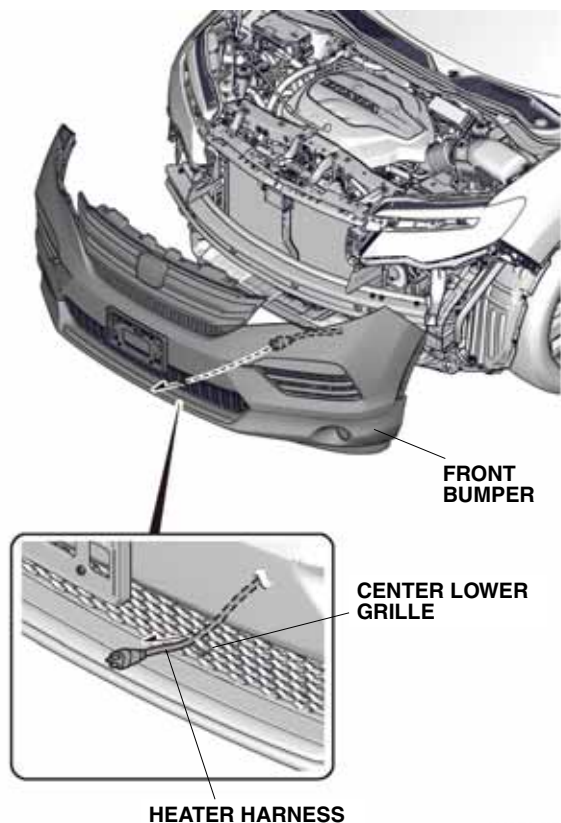

25. Secure the heater harness to the center lower grille with two black wire ties.

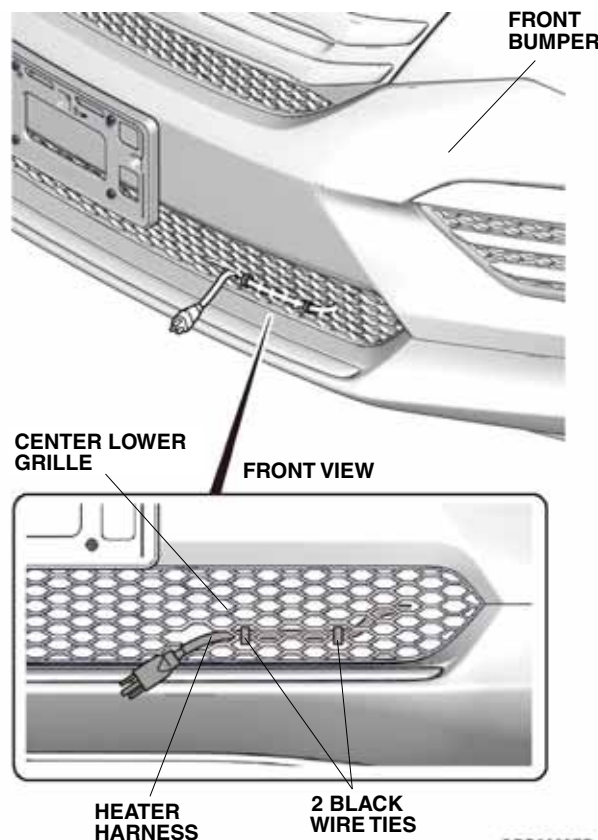

26. Attach the protective cap to the center lower grille, and plug the heater harness connector into the protective cap.

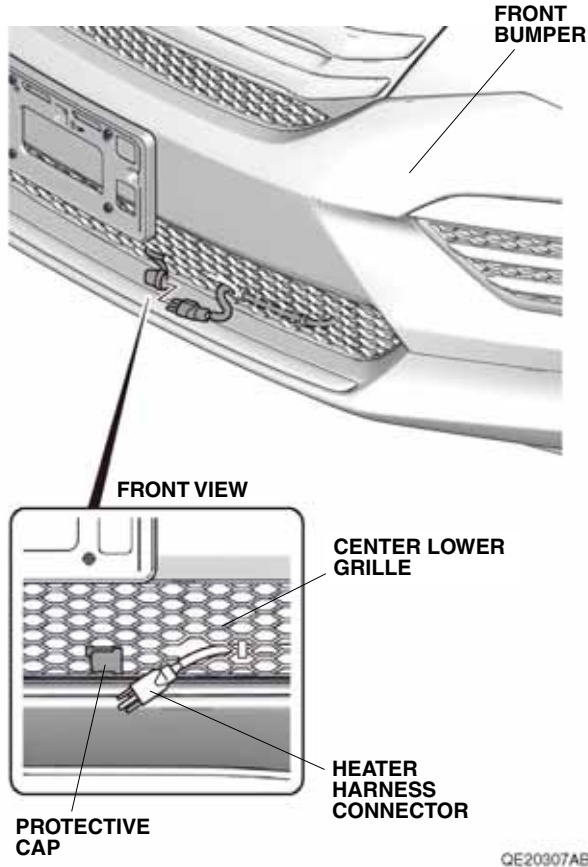

27. Reinstall all removed parts except for the front grille cover and the intake air tube.
28. Reinstall the radiator drain plug.
29. Remove the radiator cap and fill the system with the recommended coolant. Follow the instructions in the Service Manual to fill the cooling system and check for leaks. Particularly around the engine block heater.
30. Make sure that the heater harness is routed properly and all connectors are plugged in.
31. Reinstall the radiator cap.
32. Put the drain bolt (removed in step 13) in the glove box.
33. Connect the negative cable to the battery.
34. Install the front grille cover and the intake air tube.
35. Press and hold the audio power button for two seconds to restore audio and navi (if equipped) system functions.
36. Reset the clock on vehicle without navi.
37. If necessary, restore the systems back to normal operation as described in the Service Manual.