

**PARTS LIST**

Engine block heater

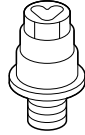

Aluminum washer



Heater harness

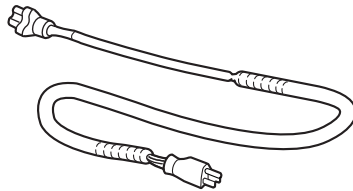

Protective cap

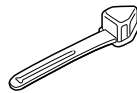
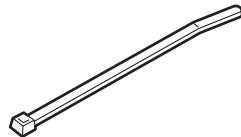
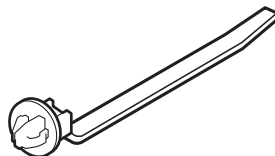
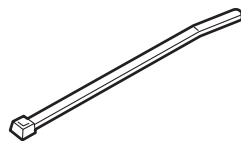
12 Black wire ties  
(2 Not used)7 Wire ties with clip  
(4 Not used)5 Wire ties (Natural)  
(4 Not used)**TOOLS AND SUPPLIES REQUIRED**

Phillips screwdriver

Flat-tip screwdriver

Ratchet

10 mm, 19 mm, and 24 mm Sockets

Torque wrench

Diagonal cutters

Heavy gloves

Drill

5 mm Drill bit

File

Drain pan

Ruler

Tape measure

White marker

Coolant (Honda All-Season Antifreeze/Coolant Type 2)

Eye protection (face shield, safety goggles, etc.)

Fender cover

Tape

Pushpin

Blanket

*The following tool is available through the Honda Tool and Equipment Program. On the iN, click on: Service > Service Bay > Tool and Equipment Program, then enter the number under "Search". Or, call 888-424-6857.*

- Plastic Trim Tool (T/N SILTRIMTL10)

## Illustration of the Engine Block Heater on the Vehicle

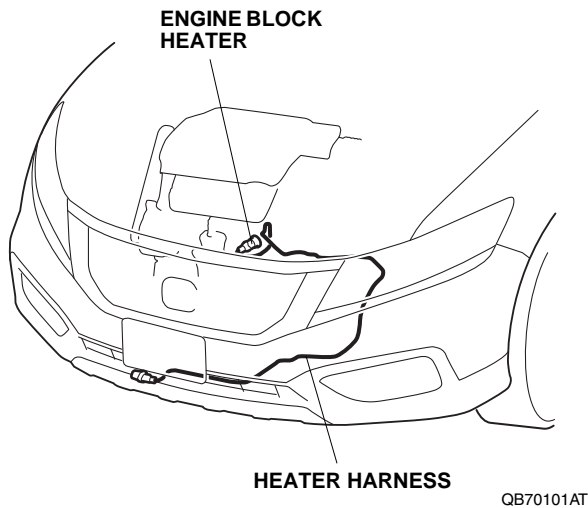

## INSTALLATION

### NOTE:

- Always use Honda All-Season Antifreeze/Coolant Type 2. Using a non-Honda coolant can result in corrosion, causing the cooling system to malfunction or fail.
- To avoid burning out the element, do not operate the engine block heater before it is installed in the vehicle and before you add coolant.

**Customer Information:** The information in this installation instruction is intended for use only by skilled technicians who have the proper tools, equipment, and training to correctly and safely add equipment to your vehicle. These procedures should not be attempted by “do-it-yourselfers.”

1. Make sure you have the anti-theft code for the audio unit and navigation system (if equipped), then write down the radio station presets.
2. Disconnect the negative cable from the battery.
3. Allow the engine and all cooling system components to cool down.

4. Place a clean drain pan under the radiator drain plug, then remove the drain plug from the bottom of the radiator to drain the coolant. Remove the radiator cap to increase the flow.

**NOTICE:** Radiator coolant will damage the paint. Quickly rinse any spilled coolant from the paint.

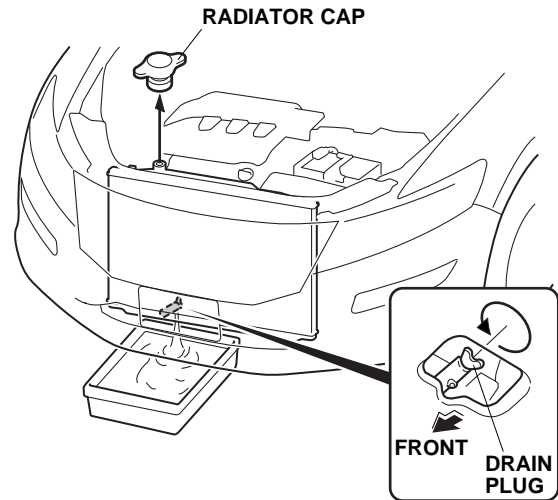

932301AS

5. Remove the front grille:
  - Remove the front grille cover (two short clips, six medium clips, and four long clips).

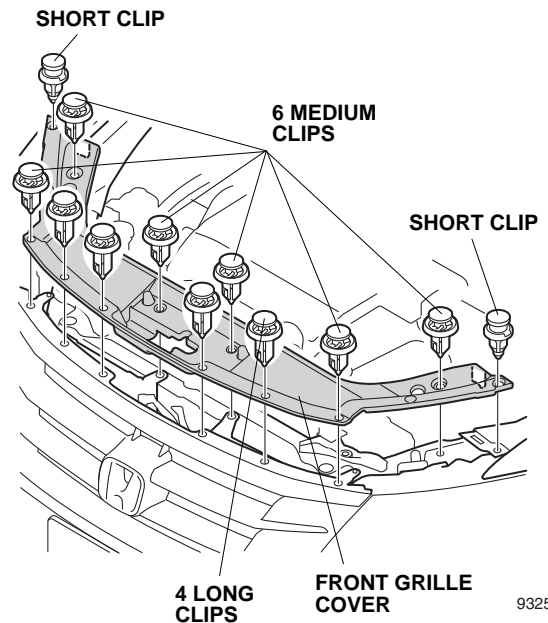

932520C

- Remove 2 self-tapping screws and 14 medium clips.

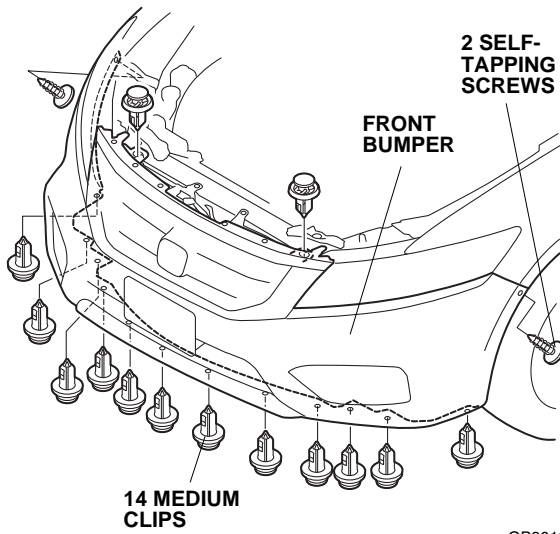

QB90103AT

- With the help of an assistant, remove the front bumper (unplug the vehicle connectors). Place the front bumper on a blanket to prevent damage.

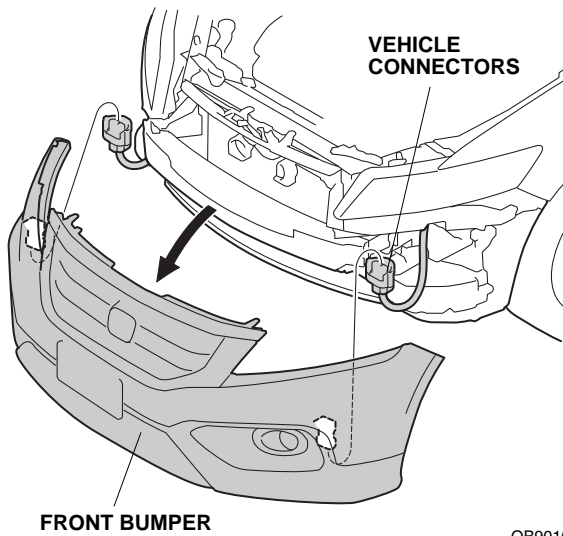

QB90104AT

- Remove the intake air box (one clip and one hook).

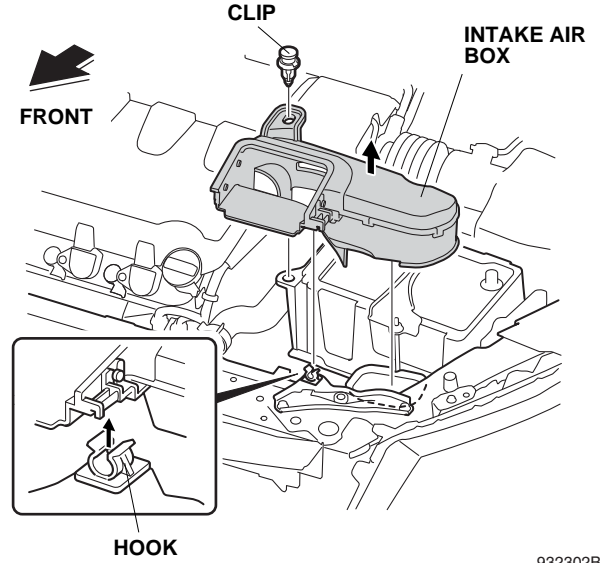

932302BS

- Remove the bumper beam cover (two screws and two tabs). Do not break the tabs.

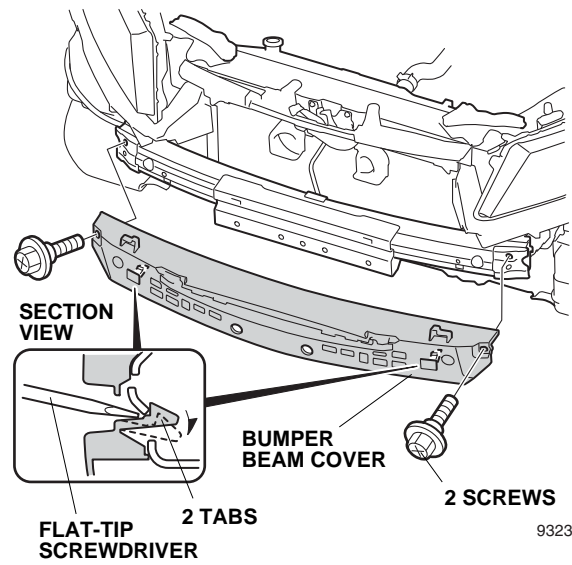

932303AS

8. Using a pushpin, pierce the bumper beam cover as shown.

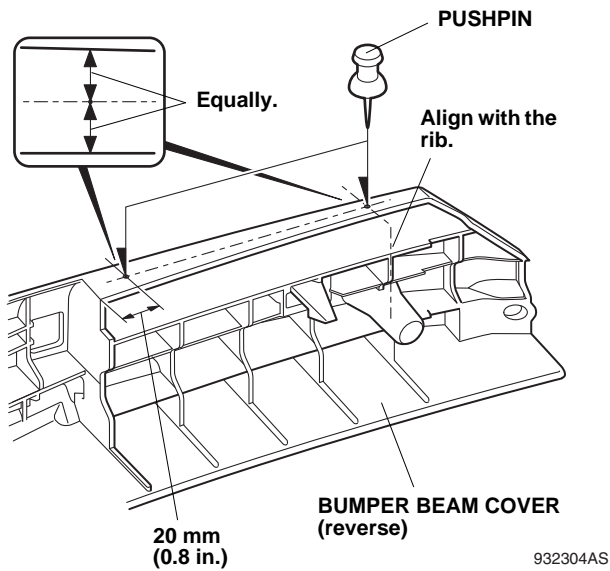

9. While wearing eye protection, drill the bumper beam cover.
- Wrap the tape around the drill bit 10 mm (0.4 in.) from the tip or use a drill stop so you don't drill through the bumper beam cover.

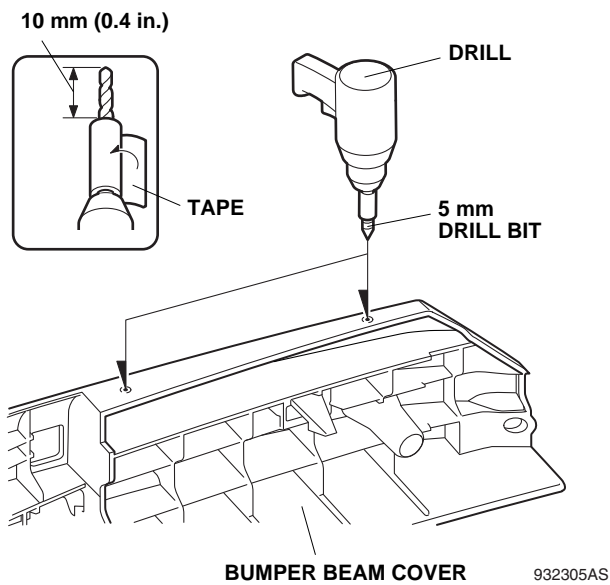

10. Remove any burrs from the edge of drilled holes.
11. Reinstall the bumper beam cover.

12. Get the heater harness. Using a tape measure, install one wire tie with clip to the heater harness at each of the measurement shown.

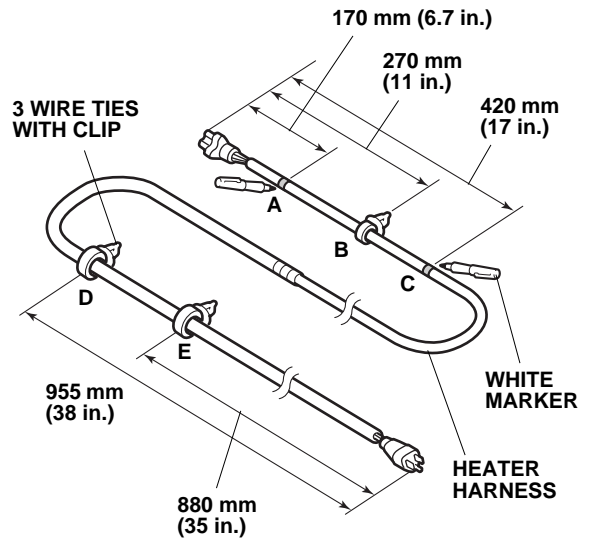

13. Using a white marker, mark the heater harness at the measurements shown.

14. Locate and remove the drain bolt and washer. Coolant remaining in the engine jackets flows out of the bolt hole when the bolt is removed. Retain the bolt; it will be used if the engine block heater is removed.  
NOTE: Use a new washer if the drain bolt is reinstalled.

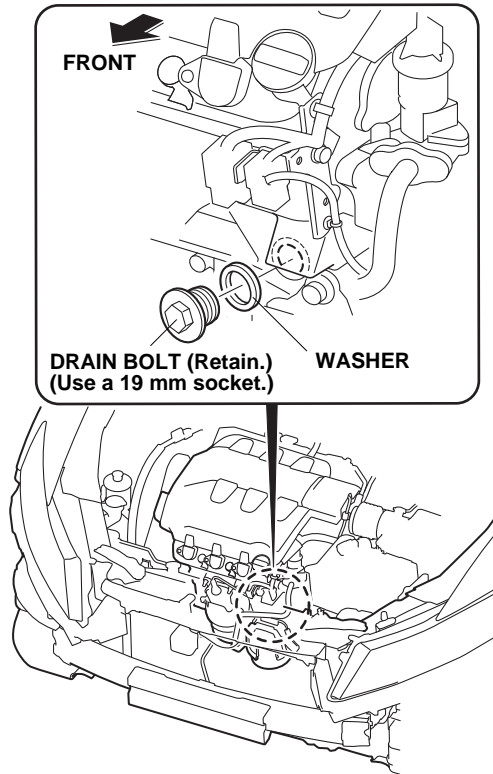

932307AS

15. Install the engine block heater with aluminum washer into the engine block using a 24 mm socket and a torque wrench. Torque the engine block heater to 85 N·m (8.5 kgf·m, 63 lbf·ft).

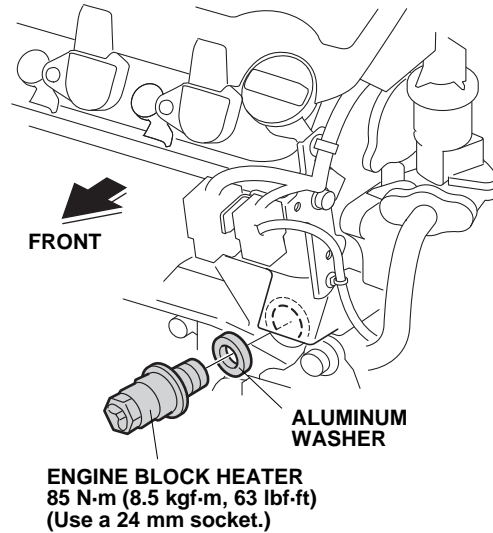

932308AS

16. Plug the connector end of the heater harness into the engine block heater. Make sure the heater harness connector is fully seated in the engine block heater.

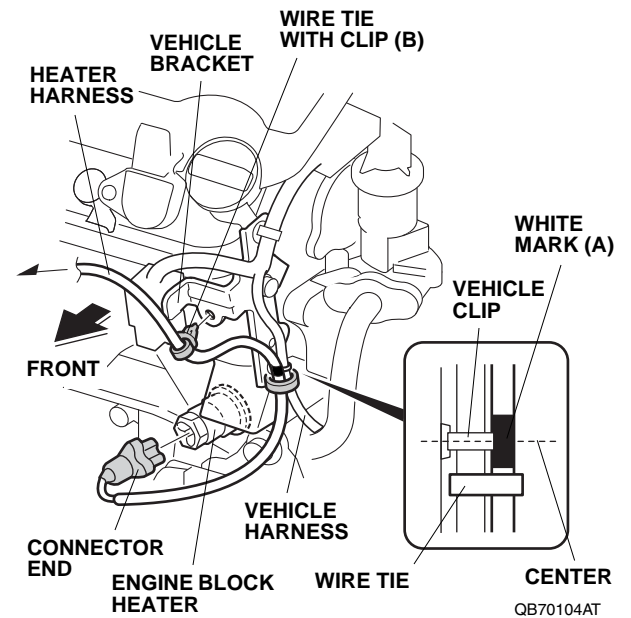

17. Using one wire tie, secure the heater harness (A) to the vehicle harness. Secure the wire tie with clip (B) to the vehicle bracket.
18. Route the heater harness as shown. Using one black wire tie, secure the heater harness (C) to the fan shroud rib.

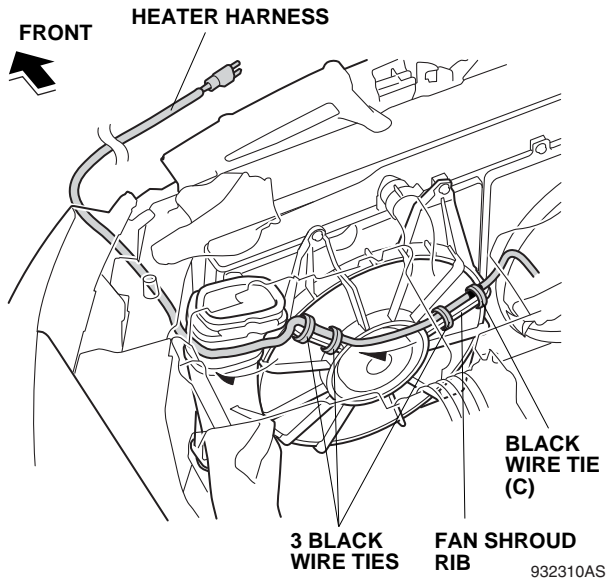

19. Using three black wire ties, secure the heater harness to the fan shroud ribs.
20. Secure the one wire tie with clip (D) to the vehicle panel. Using one black wire tie, secure heater harness to the vehicle harness.

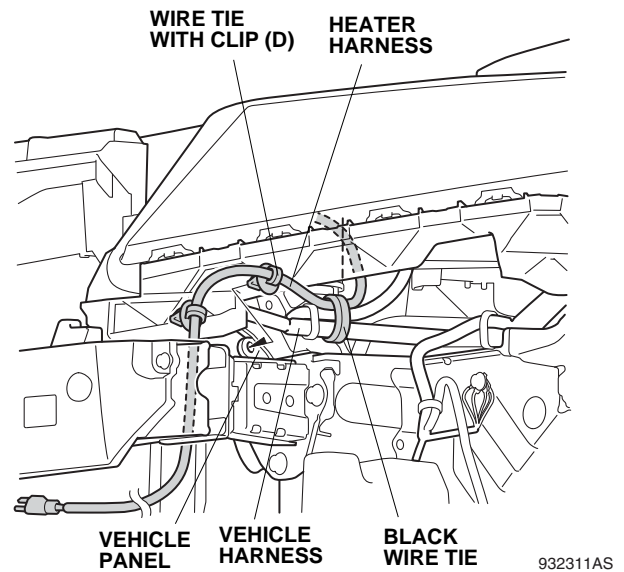

21. Secure the wire tie with clip (E) to the vehicle frame.

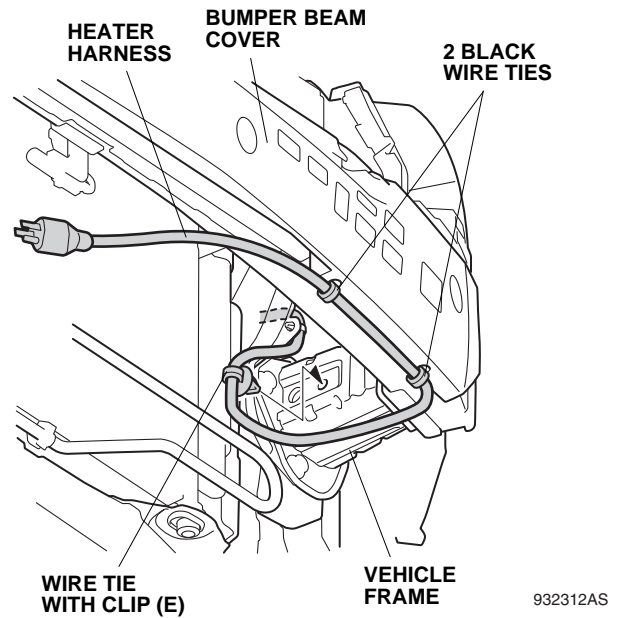

22. Using two black wire ties, secure the heater harness to the bumper beam cover.
23. With the help of an assistant, reinstall the front bumper. Route the heater harness as shown. Using three black wire ties, secure heater harness to the front bumper grille.

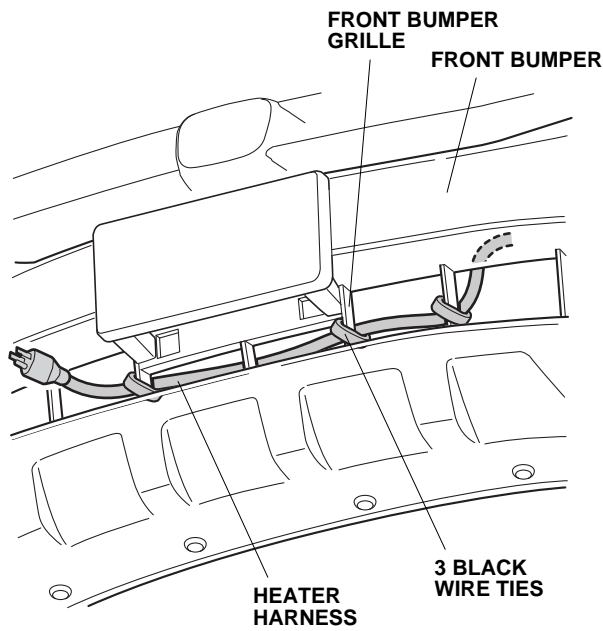

QB70102BT

24. Attach the protective cap to the front bumper grille, and plug the heater harness connector into the protective cap.

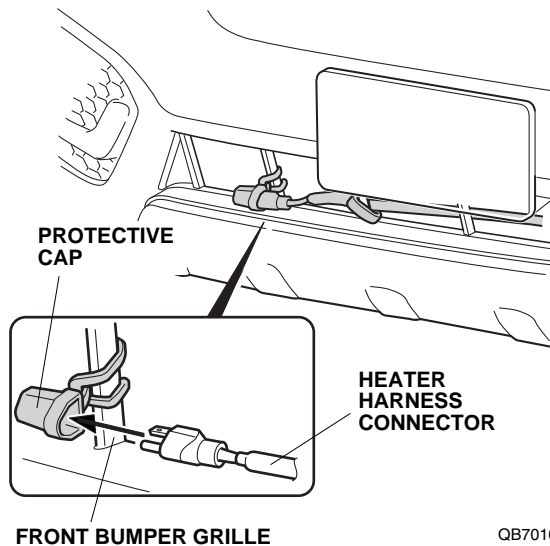

QB70103BT

25. Reinstall all removed parts.
26. Reinstall the radiator drain plug.
27. Remove the radiator cap and fill the system with the recommended coolant. Follow the instructions in the service manual to fill the cooling system and check for leaks. Particularly check that there is no leak around the engine block heater.
28. Make sure that the heater harness is routed properly and all connectors are plugged in.

29. Reinstall the radiator cap.
30. Put the drain bolt (removed in step 14) in the glove box.
31. Reconnect the negative cable to the battery.
32. Enter the anti-theft codes for the audio unit and navigation system (if equipped), and reset the radio station presets.
33. Reset the clock on the vehicles without the navigation.