



INSTALLATION INSTRUCTIONS

Accessory
PREMIUM RUNNING BOARDS
P/N 08L33-SZA-100E

Application
2012 PILOT

Publications No.
All 46391
Issue Date
AUG 2011

PARTS LIST

2 Premium running boards

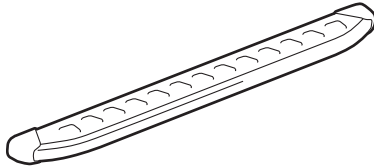

Right bracket A

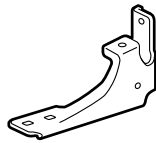

Left bracket A

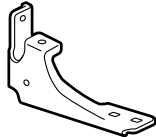

2 Right brackets B

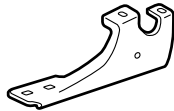

2 Left brackets B

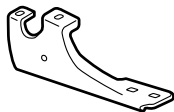

12 Flange bolts

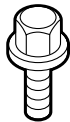

12 Flange nuts



2 Rivet nuts

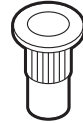

12 Square head bolts



TOOLS AND SUPPLIES REQUIRED

Torque wrench

Socket

27 mm Wrench

Hex wrench

The following tool is available through the Honda Tool and Equipment Program. On the iN, click on: Service > Service Bay > Toll and Equipment Program, then enter the number under "Search". Or, call 888-424-6857.

- Rivet nut tool (T/N LEM722M8)

Illustration of the Premium Running Boards Installed on the Vehicle

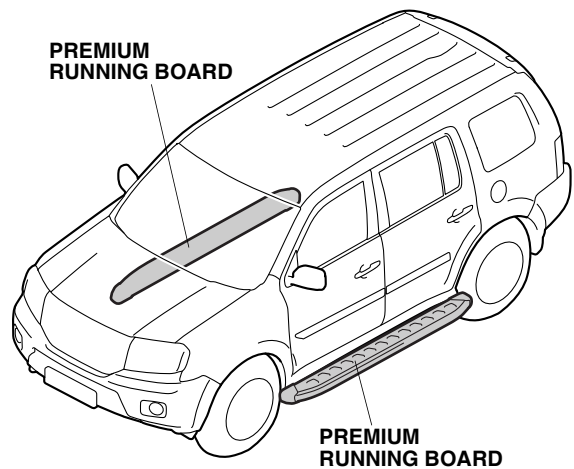

INSTALLATION

Customer Information: The information in this installation instruction is intended for use only by skilled technicians who have the proper tools, equipment, and training to correctly and safely add equipment to your vehicle. These procedures should not be attempted by “do-it-yourselfers.”

NOTE:

- Thoroughly clean the bottom of the body from the rear of the front wheels up to the front of the rear wheels.
- Be careful not to damage the body paint finish. To prevent damage, place a blanket under the premium running board during the installation.
- These instructions show the premium running board being installed on the left side of the vehicle; the same procedure applies to installing the premium running board on the right side of the vehicle.

1. Install the rivet nut to the vehicle frame as shown.

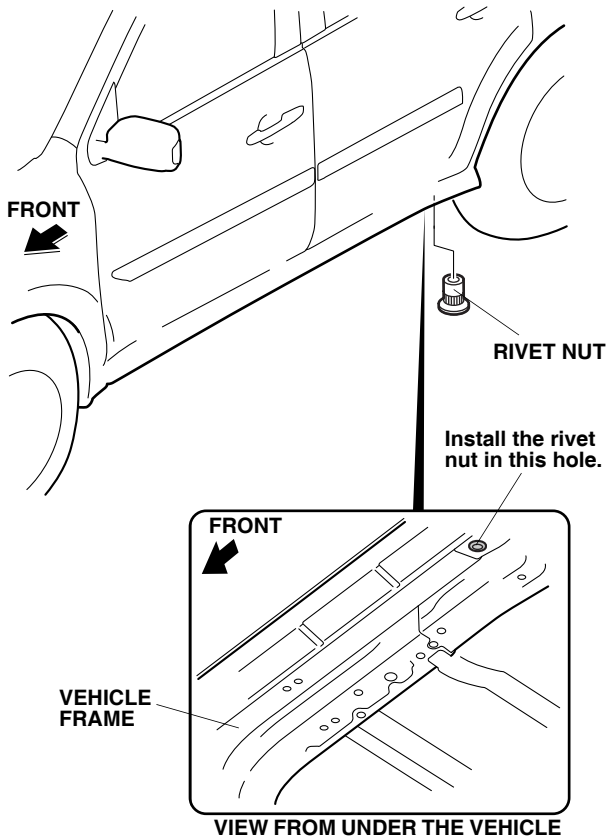

- Thread the rivet nut onto the mandrel of the rivet nut tool as shown.

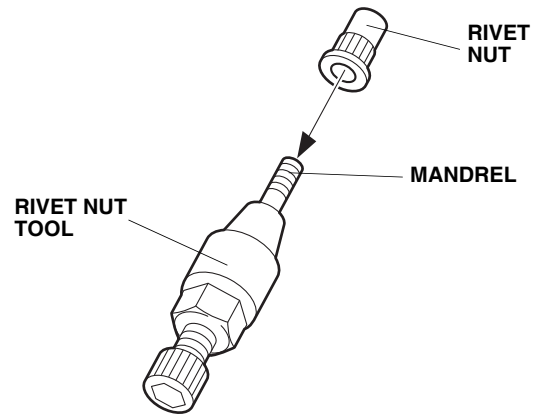

- Insert the rivet nut into the hole in the vehicle frame and install the hex wrench on the rivet nut tool.

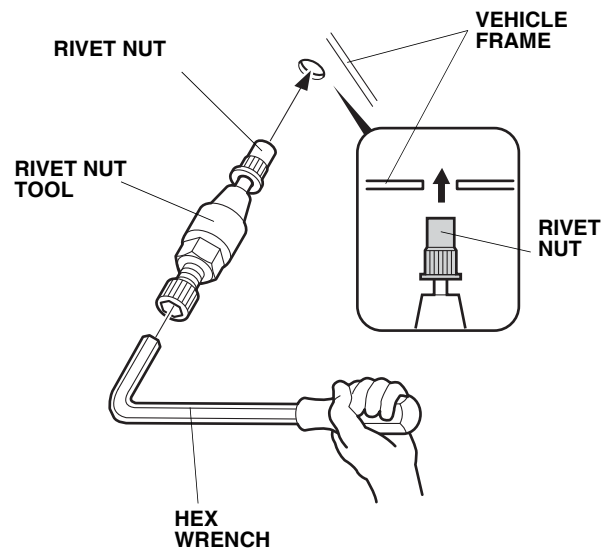

- While holding the rivet nut tool with the hex wrench, use a 27 mm wrench to turn the tool clockwise to install the rivet nut into the hole in the vehicle frame.

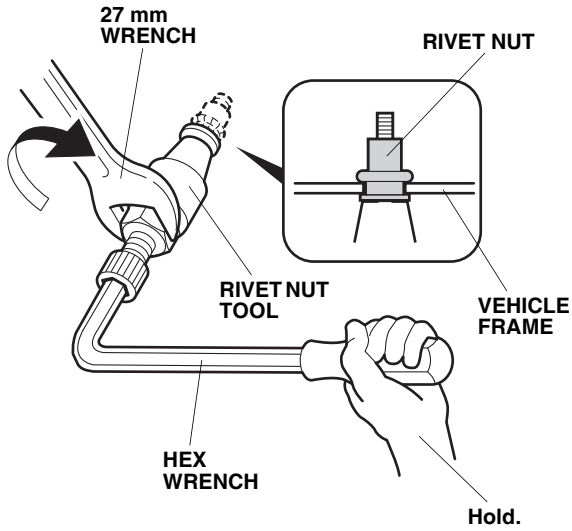

- Remove the rivet nut tool from the rivet nut by turning the hex wrench counterclockwise.

2. Position left bracket A onto the vehicle frame in the area shown, and loosely install it using two flange bolts. Do not tighten the flange bolts at this time. Make sure the flange bolts are installed into the correct locations.

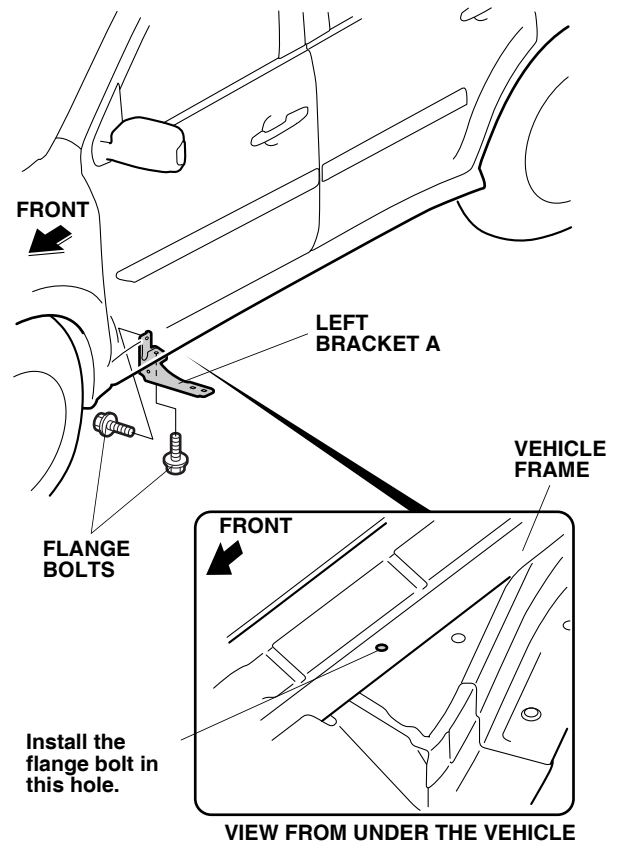

- Position the two left brackets B onto the vehicle frame in the areas shown, and loosely install them using two flange bolts for each bracket. Do not tighten the flange bolts at this time. Make sure the flange bolts are installed into the correct holes.

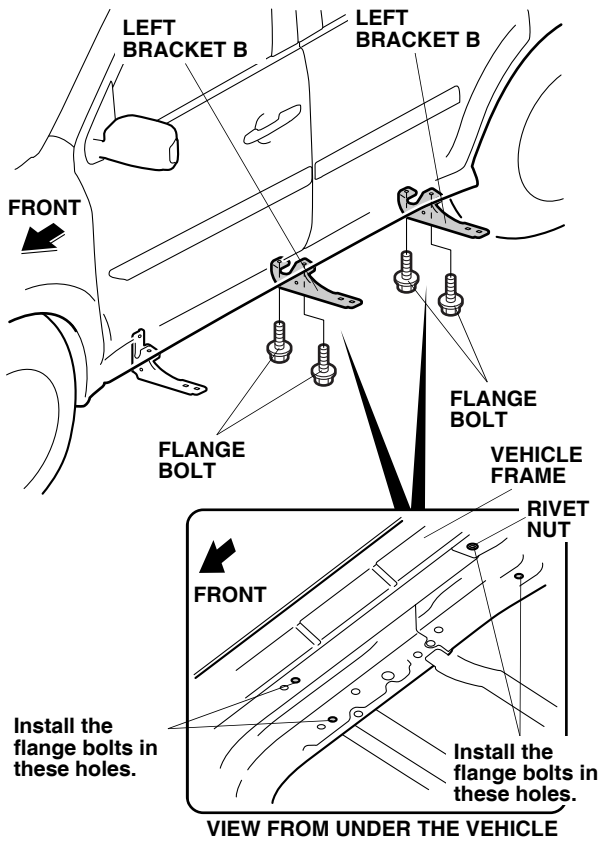

- Slide three square head bolts into each groove on the bottom of the premium running board.

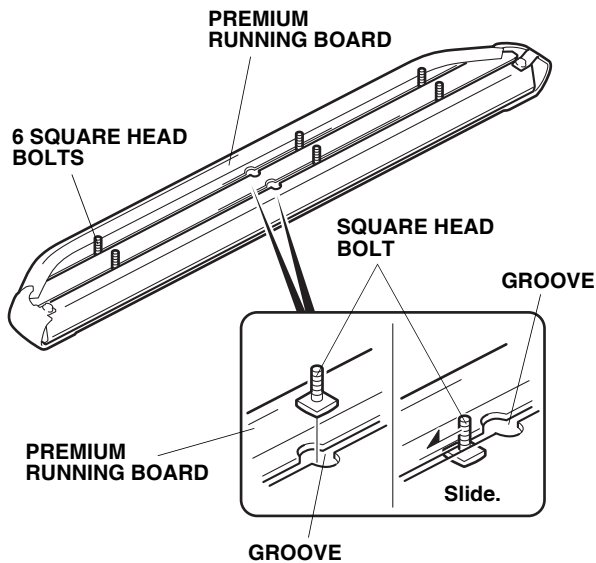

- Position the premium running board onto the left brackets, align the square head bolts with the holes in the brackets and loosely install the six flange nuts. Do not tighten the flange nuts at this time.

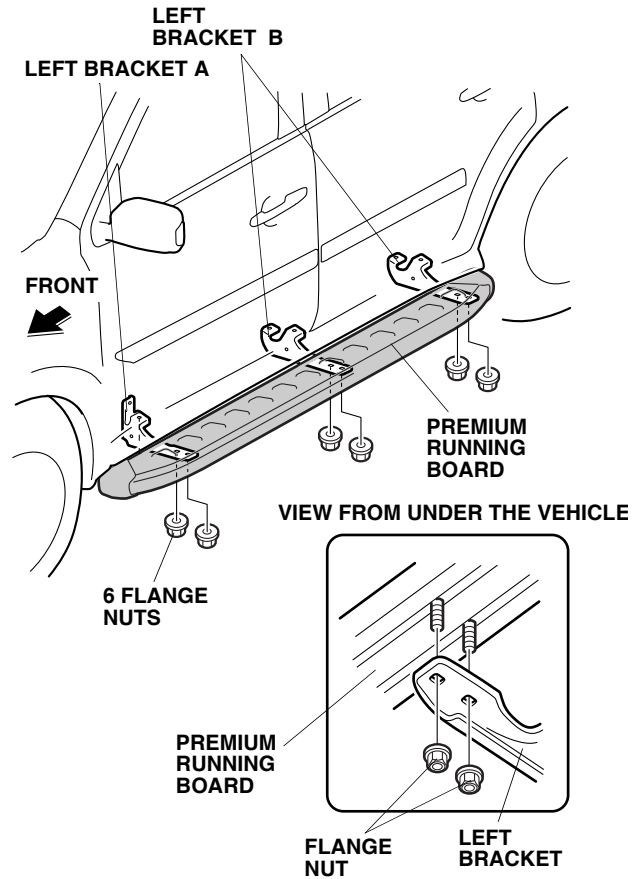

- Center the premium running board on the left side of the vehicle, and tighten the six flange nuts loosely installed in step 5. Torque the flange nuts to 27 N·m (19 lbf·ft).

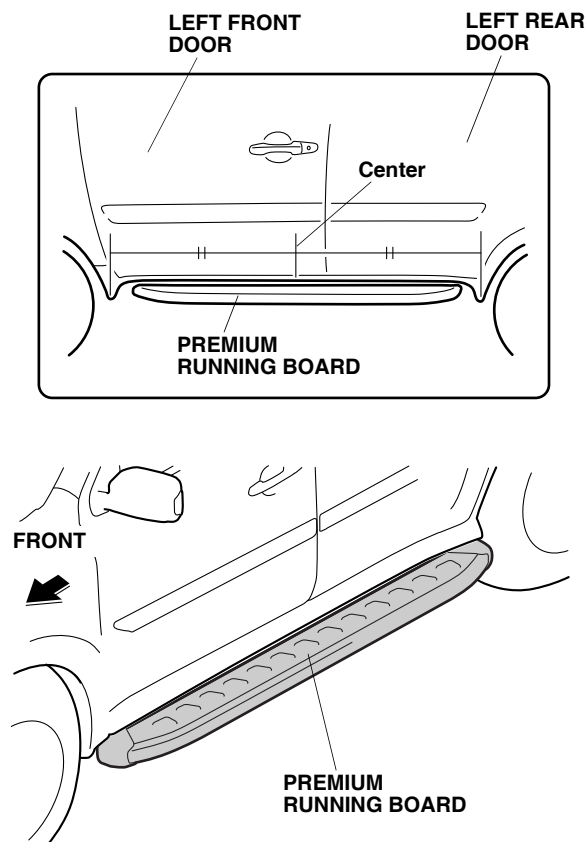

- Tighten the six flange bolts loosely installed in step 2 and step 3. Torque the flange bolts to 27 N·m (19 lbf·ft).
- Repeat steps 1 through 7 to install the running board on the right side of the vehicle.