



INSTALLATION INSTRUCTIONS

Accessory
DOOR VISORS
P/N 08R04-TP6-100

Application
2012 CROSSTOUR

Publications No.
All 46178
Issue Date
JULY 2011

PARTS LIST

Left front door visor

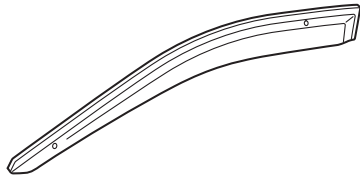

Right front door visor

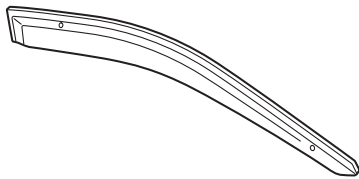

Left rear door visor

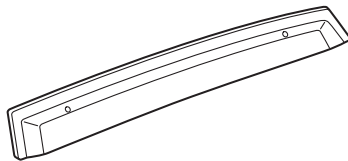

Right rear door visor

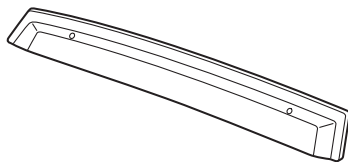

8 Brackets

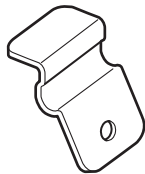

8 Clips



TOOLS AND SUPPLIES REQUIRED

- Isopropyl alcohol
- Shop towel
- Soft towel
- Masking tape
- Ruler

Illustration of the Door Visors Installed on the Vehicle

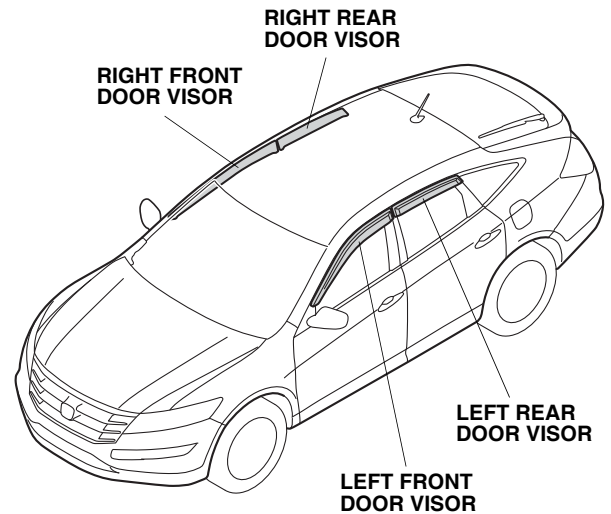

INSTALLATION

NOTE:

- Visors may not be legal in all states, please check the laws of your state.
- These instructions show the left door visors being installed. The same procedure applies to installing the right door visors.
- Take care not to damage the paint finish and glass run channels when installing the door visors.
- Handle the door visors with care. They are not designed to absorb shock or impact.
- The door visors should be installed only if the ambient air temperature is 15°C (60°F) or above.
- To allow the adhesive to cure, do not wash the vehicle for 24 hours. Please advise the customer.

Installing the Front Door Visor

1. Fully open the driver's window.
2. Peel back the glass run channel in the areas shown.

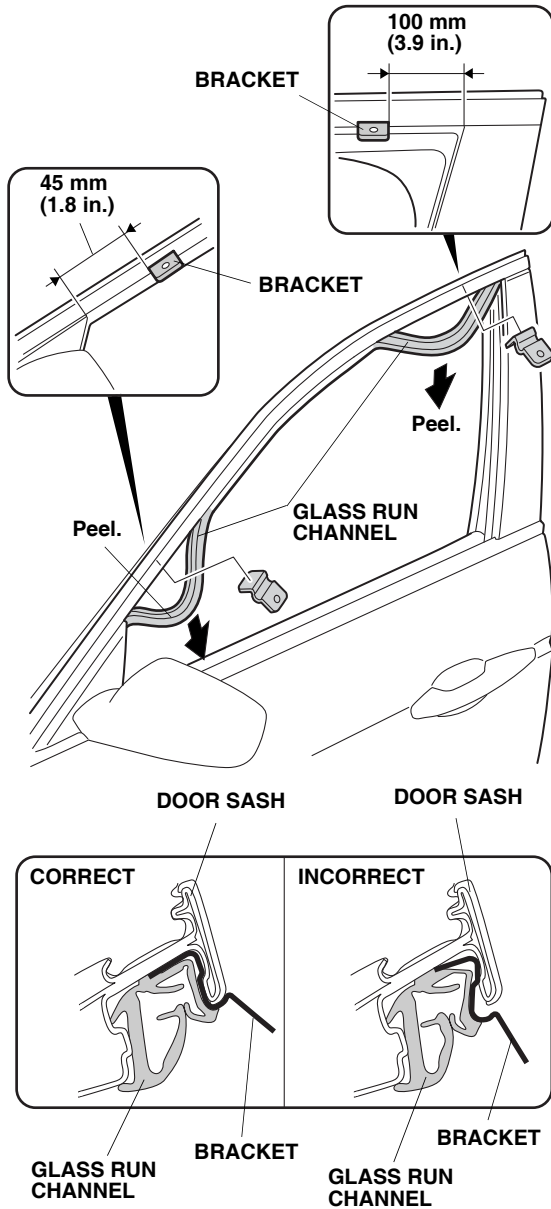

3. Install two brackets between the door sash and the glass run channel at the measurements shown. Then seat the glass run channel properly around the brackets.

4. Using isopropyl alcohol on a shop towel, thoroughly clean the area where the left front door visor will attach.

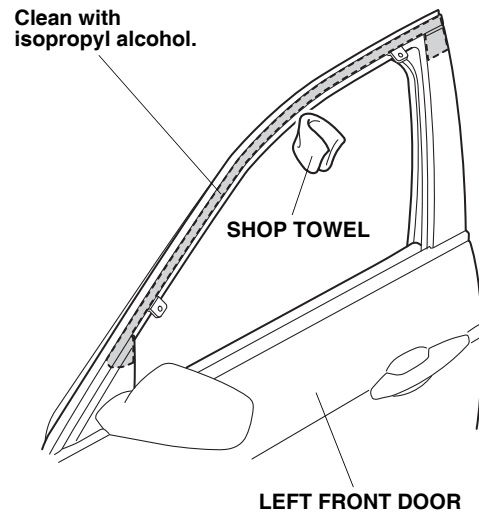

5. Peel back approximately 25-35 mm (1-1.5 inches) of adhesive backing, and tape the ends to the front surface of the left front door visor.

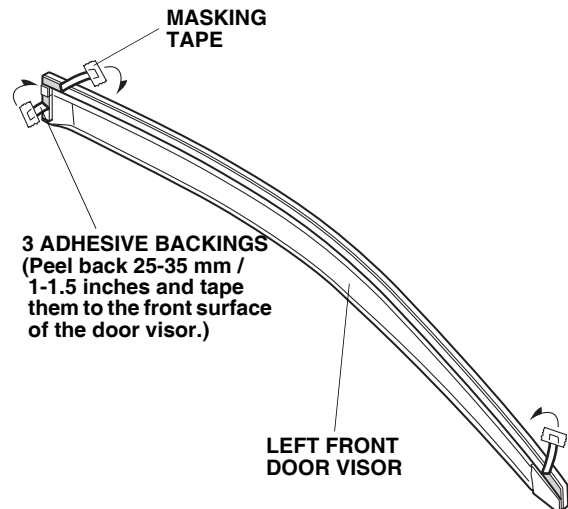

6. Align the clip holes in the visor with the bracket holes, and install two clips. There should be no clearance between the brackets and the door sash.

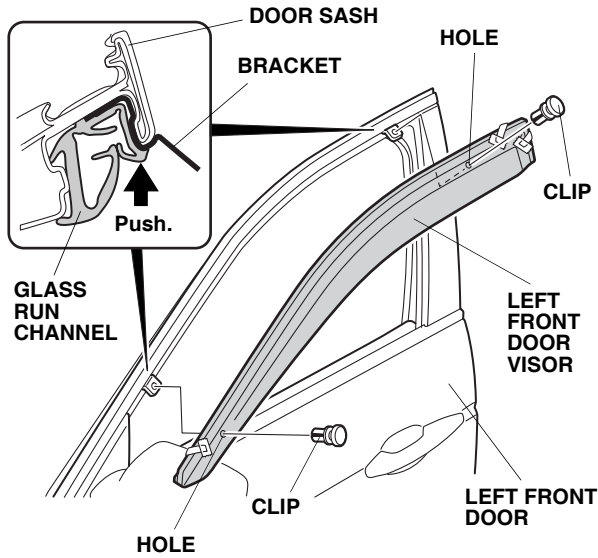

7. Align the door visor with the edge of the end cap.

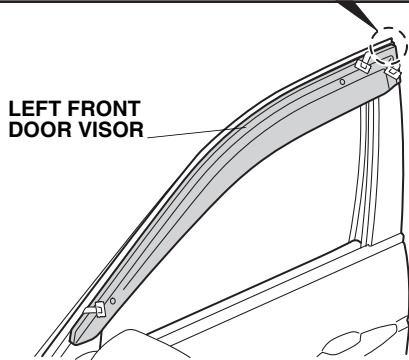
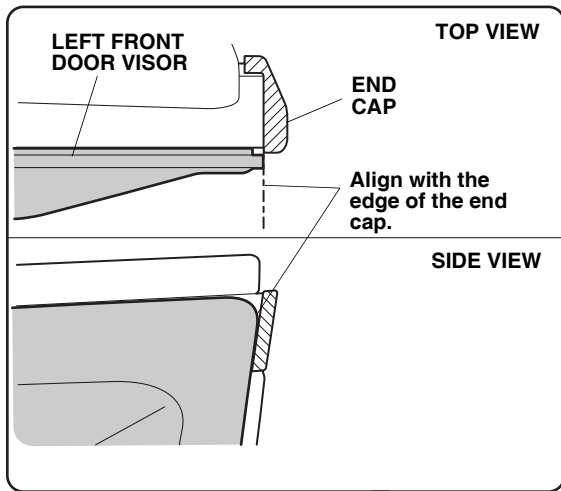

8. While holding the door visor up firmly, remove the adhesive backing in the order shown. Use your finger to push up each bracket so there is no gap between the brackets and the door sash.

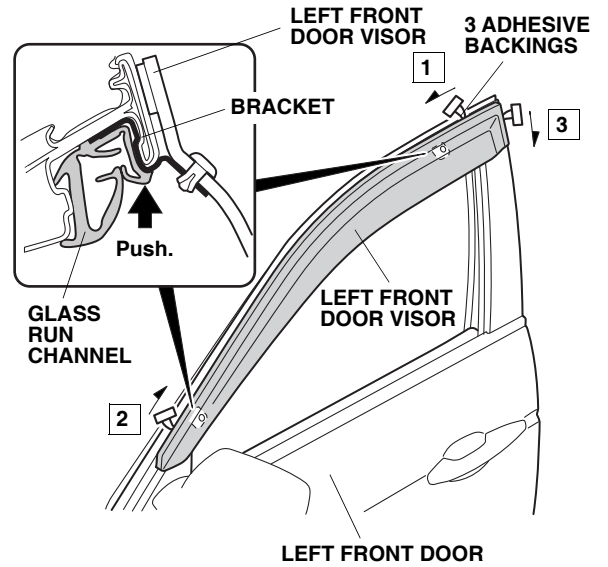

9. Using a soft towel, press and hold the left front door visor against the door for 30 seconds.

Installing the Rear Door Visor

10. Fully open the left rear window.

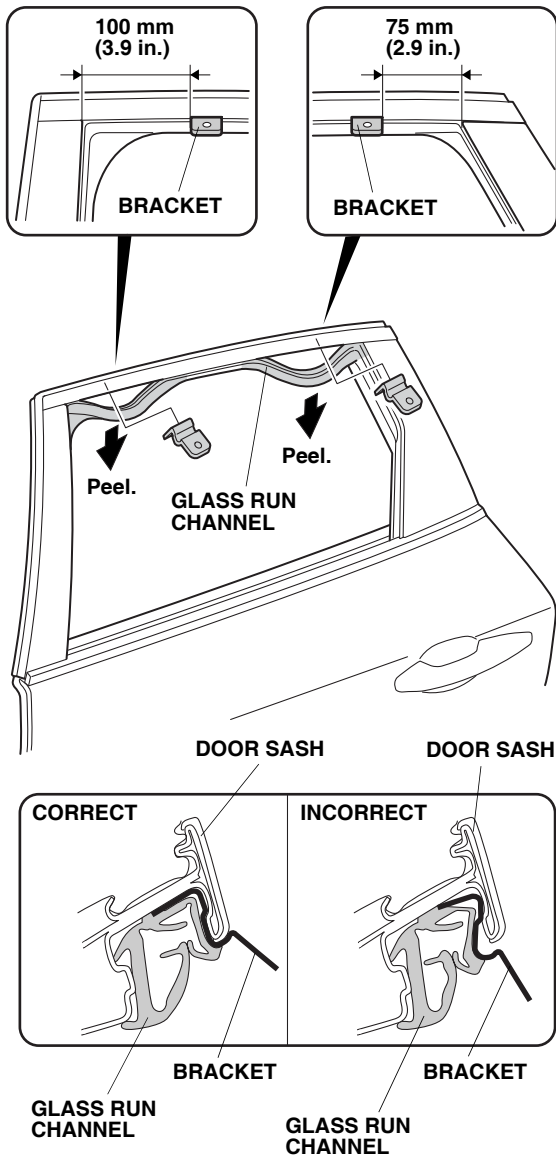

11. Peel back the glass run channel in the areas shown.
 12. Install two brackets between the door sash and the glass run channel at the measurements shown. Then seat the glass run channel properly around the brackets.

13. Using isopropyl alcohol on a shop towel, thoroughly clean the area where the left rear door visor will attach.

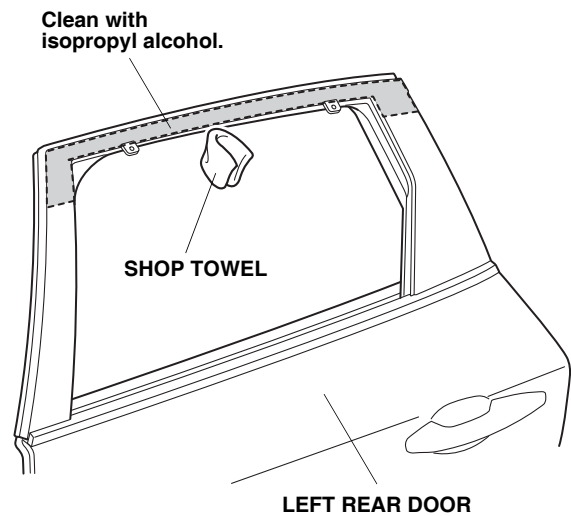

14. Peel back approximately 25-35 mm (1-1.5 inches) of adhesive backing, and tape the ends to the front surface of the left rear door visor.

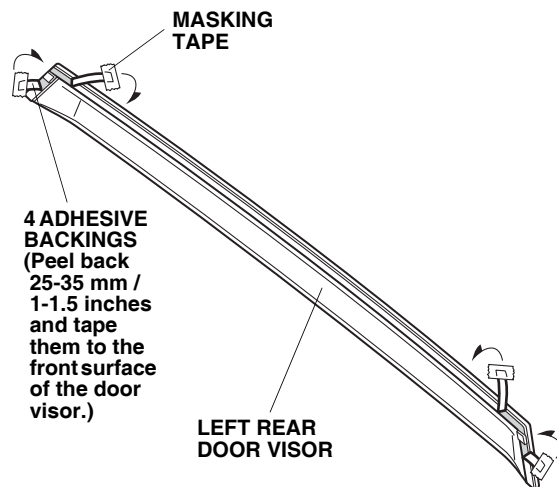

15. Align the clip holes in the visor with the bracket holes, and install two clips. There should be no clearance between the brackets and the door sash.

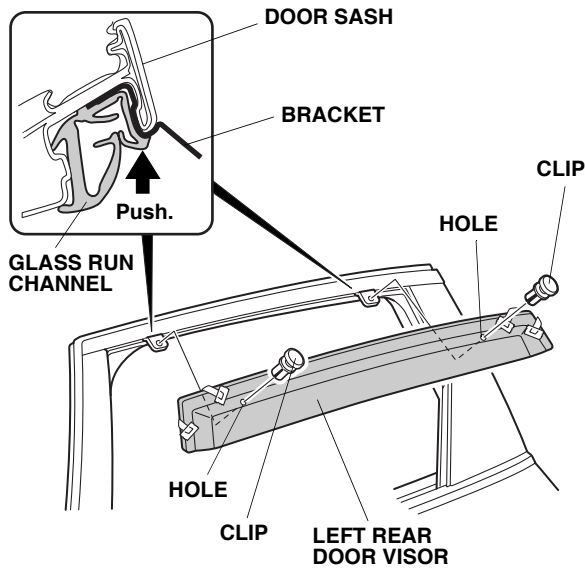

16. Align the door visor with the edge of the end cap.

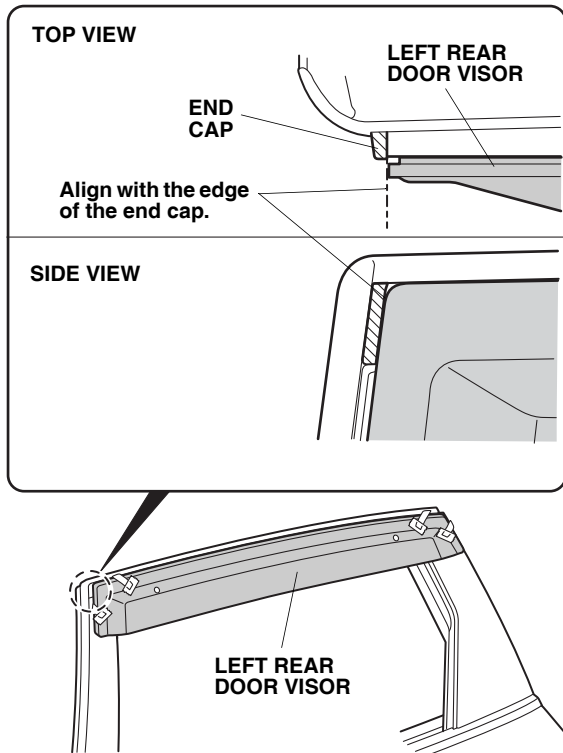

17. While holding the door visor up firmly, remove the adhesive backing in the order shown. Use your finger to push up each bracket so there is no gap between the brackets and the door sash.

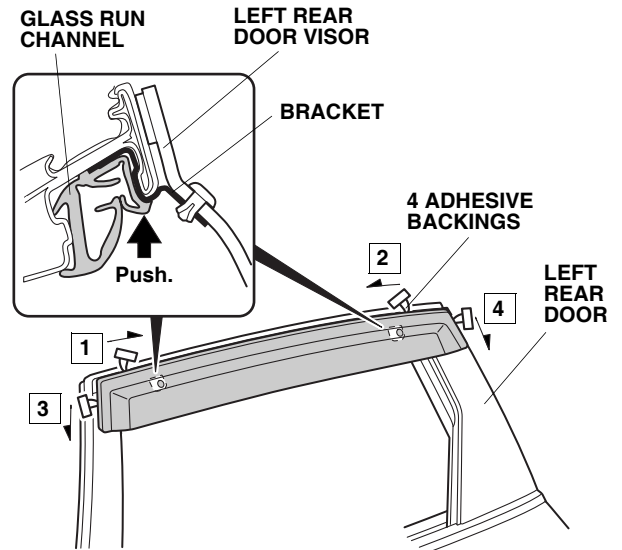

18. Using a soft towel, press and hold the left rear door visor against the door for 30 seconds.
19. Repeat steps 1 through 18 to install the door visors on the right side of the vehicle.

CONFIRMATION AFTER INSTALLATION

RESTORATION OPERATIONS

1. Start the engine.
2. Using the power window switch, open and close the window from half-open to fully closed 10 times to allow the run channel to seat. (The window should not bind.)
3. If necessary, refer to the service manual to reset the power window. (If the automatic closing/opening does not function after the reset, reset again.)
4. If necessary, refer to the service manual to carry out “learning” of the power window. (If the automatic closing/opening does not function after the learning, carry out “learning” again.)

NOTE: The operations in steps 3 and 4 should be done to all power windows having the automatic closing/opening function to allow for proper functioning of the auto-reverse function after installing the door visors.

USE AND CARE

Clean the door visors with mild detergent and water. Do not use organic solvent (any thinners, benzine, alcohol, etc.) or cleaners containing any abrasive material.