



INSTALLATION INSTRUCTIONS

Accessory
ENGINE BLOCK HEATER (V6)
P/N 08T44-SNA-101

Application
2012 ACCORD
2- AND 4-DOOR

Publications No.
All 46508

Issue Date
AUG 2011

PARTS LIST

ENGINE BLOCK HEATER

Engine block heater

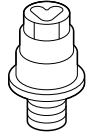

Aluminum washer



Heater harness

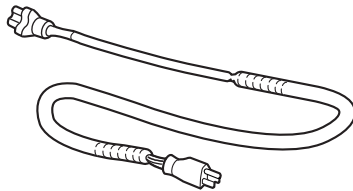

Protective cap

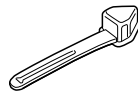

12 Black wire ties
(3 Not used)

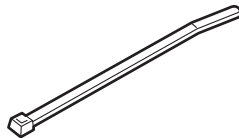

7 Wire ties with clips
(5 Not used)

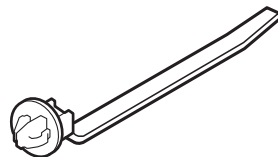

5 White wire ties
(4 Not used)

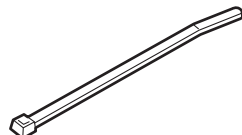

TOOLS AND SUPPLIES REQUIRED

Ratchet

10 mm, 12 mm, 19 mm, and 24 mm Sockets

Torque wrench

Diagonal cutters

Heavy gloves

Drain pan

Tape measure

White marker

Honda All Season Antifreeze/Coolant Type 2,
P/N 0L999-9011A

Honda Coolant Concentrate, P/N 0L999-9020

Fender cover

INSTALLATION

NOTE:

- Always use Honda All Season Antifreeze/Coolant Type 2. Using a non-Honda coolant can result in corrosion, causing the cooling system to malfunction or fail.
- To avoid burning out the element, do not operate the engine block heater until it is installed in the vehicle and you have added coolant.

Customer Information: The information in this installation instruction is intended for use only by skilled technicians who have the proper tools, equipment, and training to correctly and safely add equipment to your vehicle. These procedures should not be attempted by “do-it-yourselfers.”

1. Make sure you have the anti-theft code for the audio system and the navigation system (if equipped).
2. Disconnect the negative cable from the battery.
3. Allow the engine and all cooling system components to cool down.
4. Place a clean drain pan under the radiator drain plug, then remove the drain plug from the bottom of the radiator to drain the coolant. Remove the radiator cap to increase the flow.

NOTICE

Radiator coolant will damage paint. Quickly rinse any spilled coolant from painted surfaces.

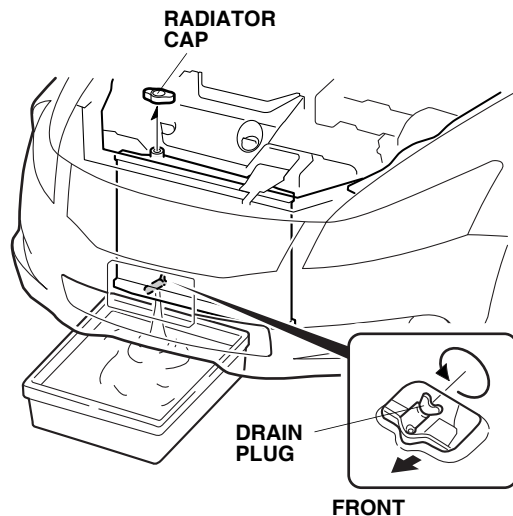

5. Remove the intake air box (one clip and one hook).

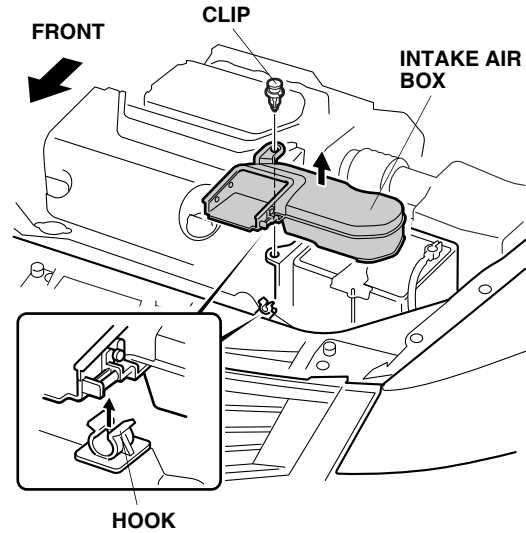

6. Disconnect the negative (-) cable from the battery, open the positive cable cover and disconnect the positive (+) cable from the battery. Unfasten the two battery holder nuts and remove the battery holder.

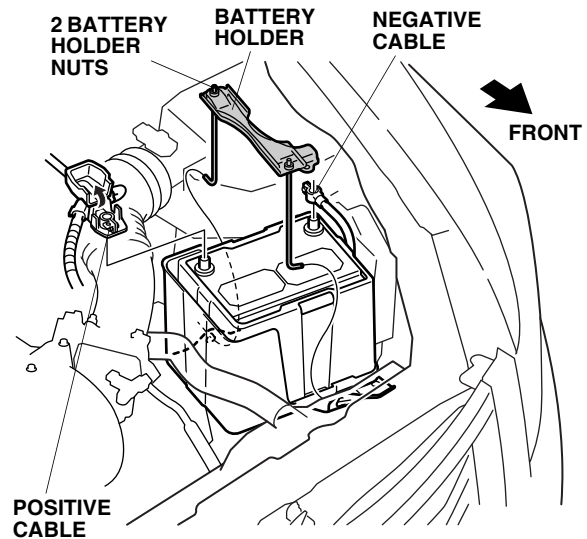

7. Remove the battery cover, battery, and battery box.

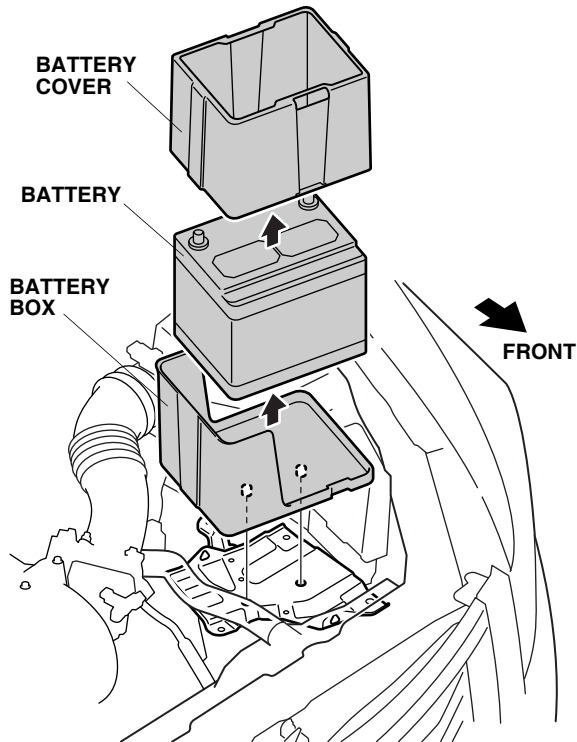

8. Using a tape measure, install one wire tie with clip to the heater harness at the measurement (B) shown.

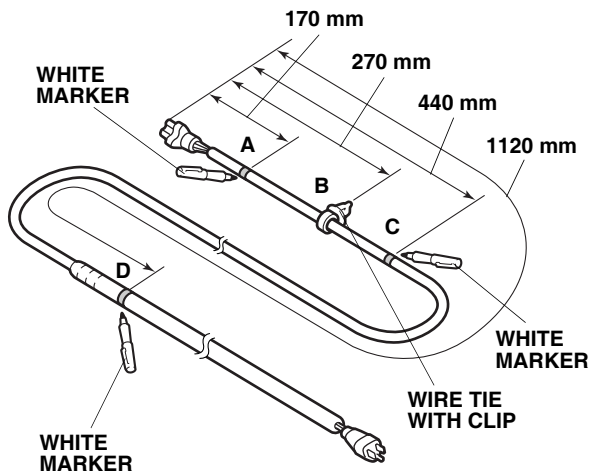

9. Using a white marker, mark the heater harness at the measurements shown.

10. Locate and remove the engine block drain bolt and washer. Coolant remaining in the engine jackets will flow out of the hole when the bolt is removed. (Retain the bolt and washer in case the engine block heater is removed.)

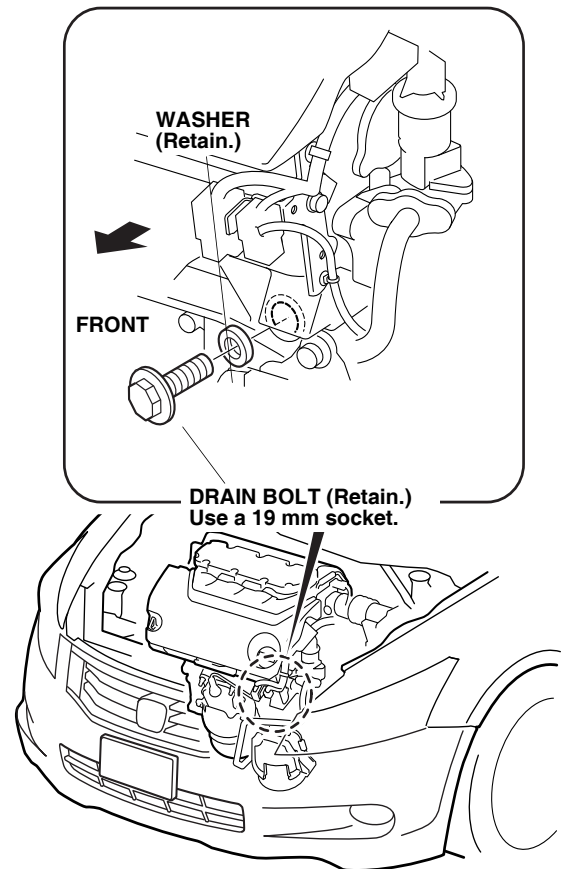

11. Install the engine block heater with the aluminum washer into the engine block using a 24 mm socket and a torque wrench. Torque the engine block heater to 60 N·m (44 lbf-ft).

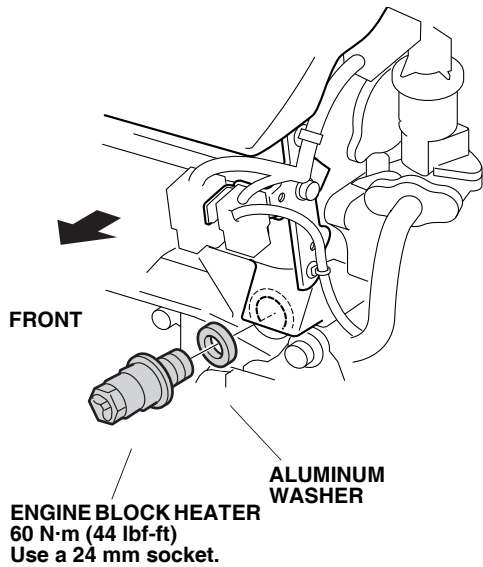

12. Plug the connector on the heater harness into the engine block heater.

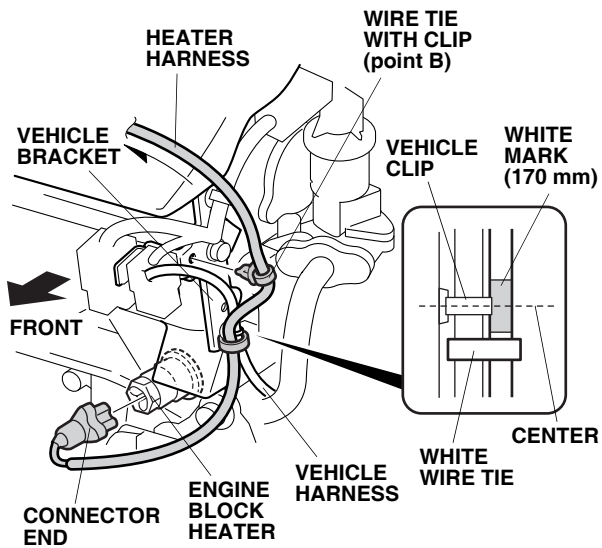

13. Route the heater harness as shown and secure the heater harness to the vehicle harness with one white wire tie at the 170 mm mark you made. Secure the one wire tie with clip (270 mm) to the vehicle bracket.

14. Route the heater harness as shown and secure it to the fan shroud rib with four black wire ties.

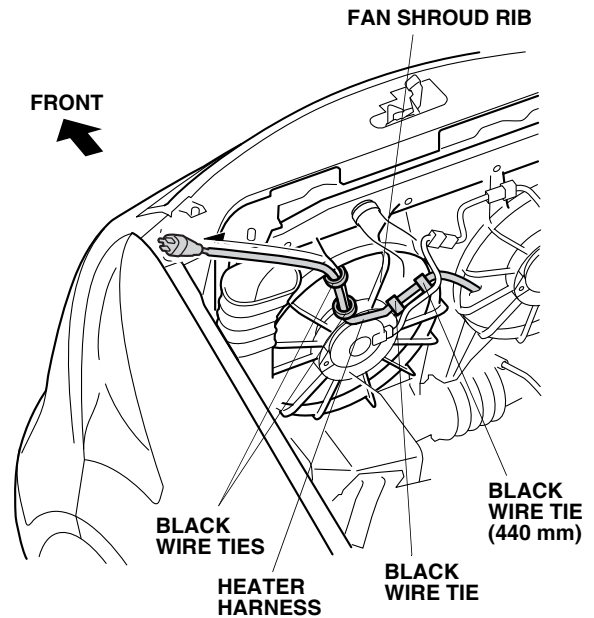

15. Route the heater harness as shown and secure it to the vehicle harness with two black wire ties.

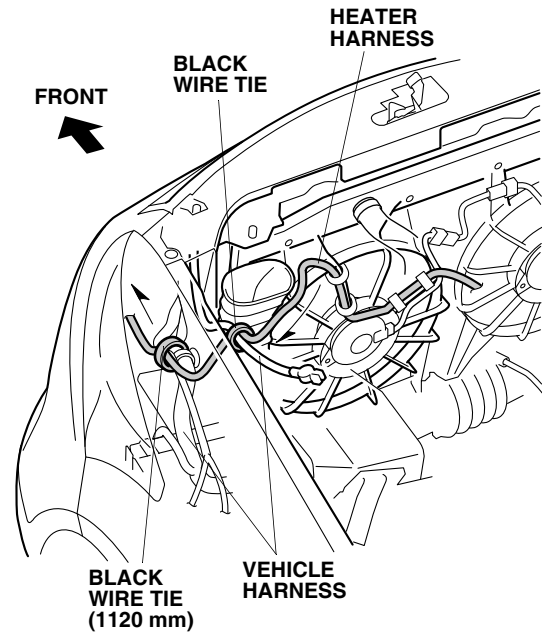

16. Route the heater harness as shown and secure the heater harness to the hole in the vehicle frame with one wire tie with clip.

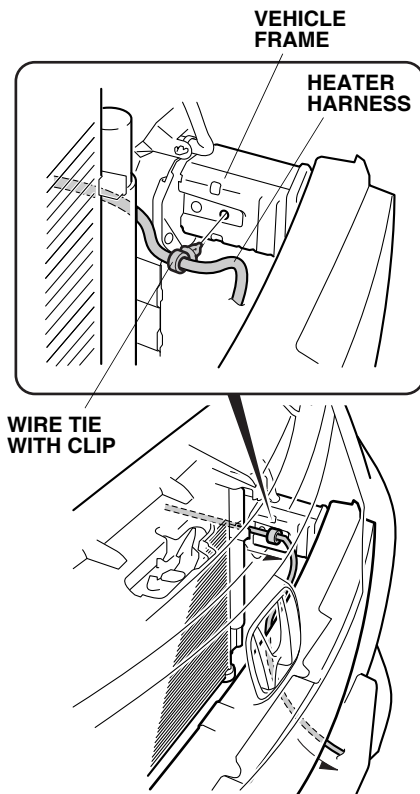

17. Route the heater harness inside the bumper and secure it with the three black wire ties.

4 Door

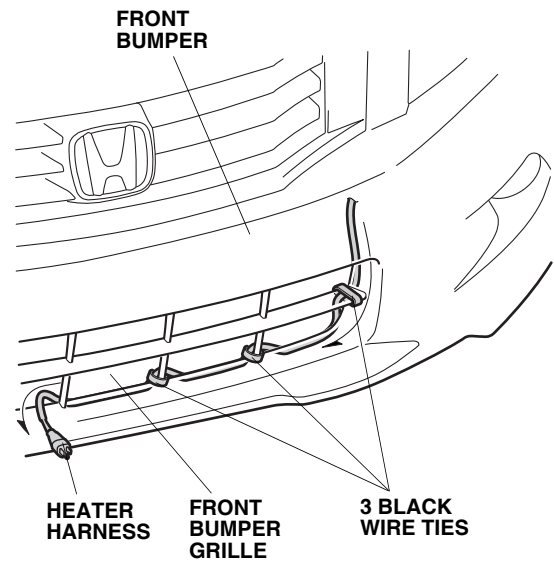

2 Door

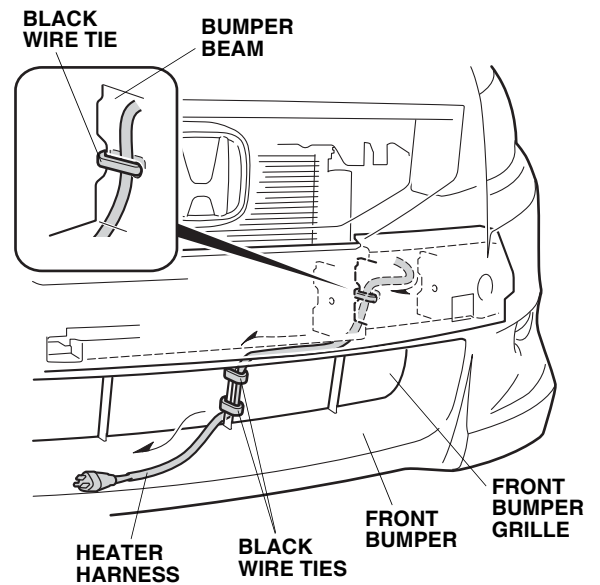

18. Attach the protective cap to the front bumper grille, and plug the heater harness connector into the protective cap.

4 Door

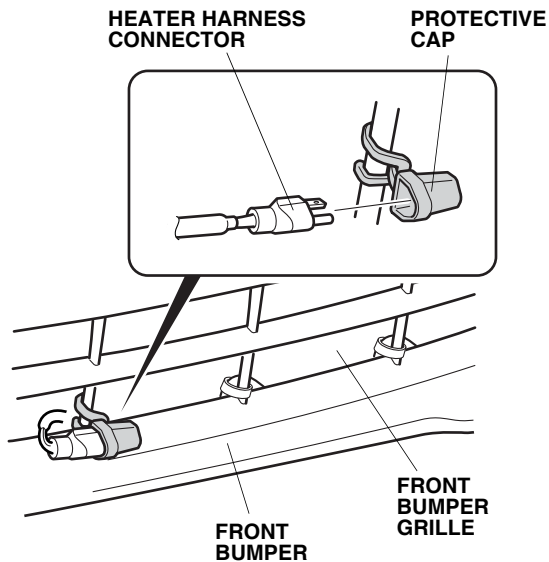

2 Door

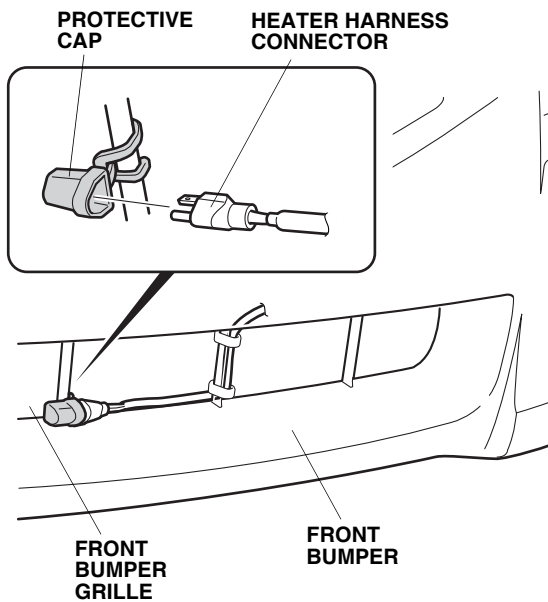

19. Reinstall all removed parts.
20. Reinstall the radiator drain plug.
21. Fill the system with the recommended coolant. Follow the instructions described in the service manual to fill and bleed the cooling system.
22. Check the coolant reservoir for correct level and check the cooling system for signs of leakage. Repair as necessary.
23. Check that the heater harness is routed properly and all connectors are plugged in.
24. Put the drain bolt (removed in step 10) in the glove box.
25. Reconnect the negative cable to the battery.
26. Enter the radio anti-theft codes for the audio system and the navigation system (if equipped).
27. Reset the clock on vehicles without navigation.