



# INSTALLATION INSTRUCTIONS

Accessory  
**ENGINE BLOCK HEATER**  
P/N 08T44-SNA-101

Application  
**2011 PILOT**

Publications No.  
**All 43310**

Issue Date  
**MARCH 2010**

## PARTS LIST

Engine block heater

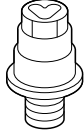

Aluminum washer



Heater harness

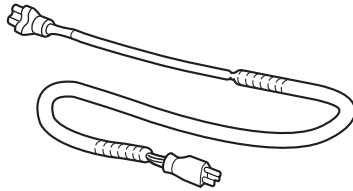

Protective cap

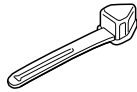

12 Black wire ties  
(2 Not used)

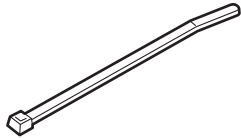

7 Wire tie with clips  
(6 Not used)

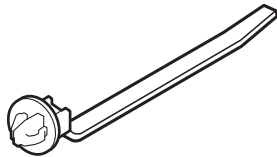

5 White wire ties  
(4 Not used)

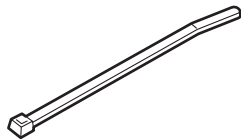

## TOOLS AND SUPPLIES REQUIRED

Ratchet

10 mm, 19 mm, and 24 mm Sockets

Torque wrench

Diagonal cutters

Heavy gloves

Drain pan

Tape measure

White marker

Coolant (Honda Genuine Antifreeze/Coolant only)

Fender cover

## INSTALLATION

### NOTE:

- Always use Honda Genuine Antifreeze/Coolant only. Using a non-Honda coolant can result in corrosion, causing the cooling system to malfunction or fail.
- To avoid burning out the element, do not operate the engine block heater until it is installed in the vehicle and you have added coolant.

**Customer Information:** The information in this installation instruction is intended for use only by skilled technicians who have the proper tools, equipment, and training to correctly and safely add equipment to your vehicle. These procedures should not be attempted by “do-it-yourselfers.”

1. Allow the engine and all cooling system components to cool down.
2. Place a clean drain pan under the radiator drain plug, then remove the drain plug from the bottom of the radiator to drain the coolant. Remove the radiator cap to increase the flow.

**NOTICE:** Radiator coolant will damage paint. Quickly rinse any spilled coolant from painted surfaces.

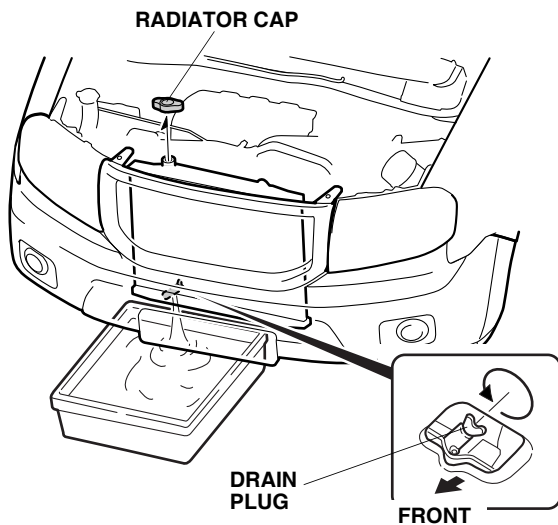

3. Remove the air intake box (two clips).

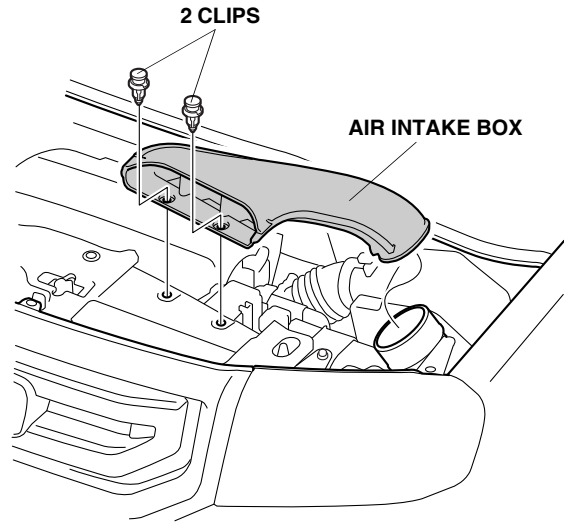

4. Remove the bulkhead cover (seven clips).

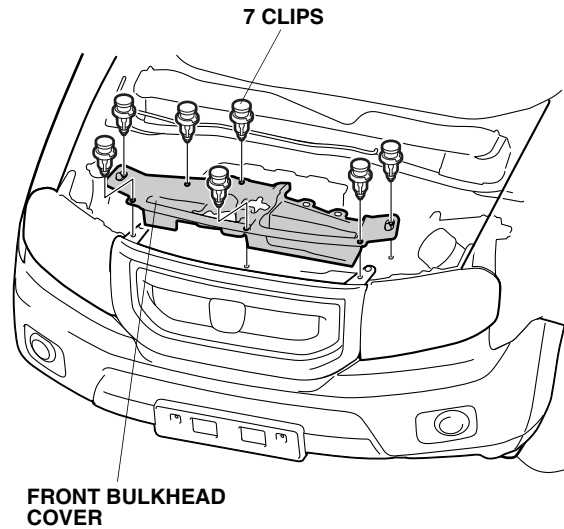

- Turn the two clips and remove the engine cover as shown.

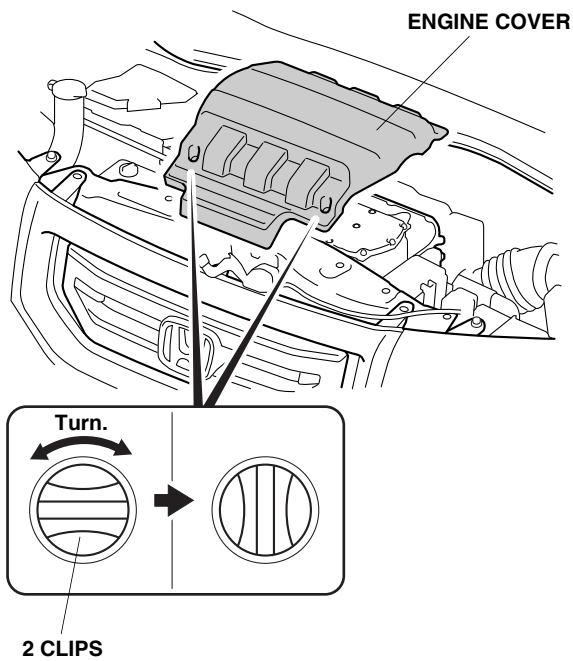

- Remove the front bumper (nine clips, four self-tapping screws, and four bolts). Have an assistant help you when removing and installing the front bumper. If the vehicle is equipped with foglights or front corner sensors, unplug the connectors. Place the front bumper on a blanket / fender cover to prevent damage.

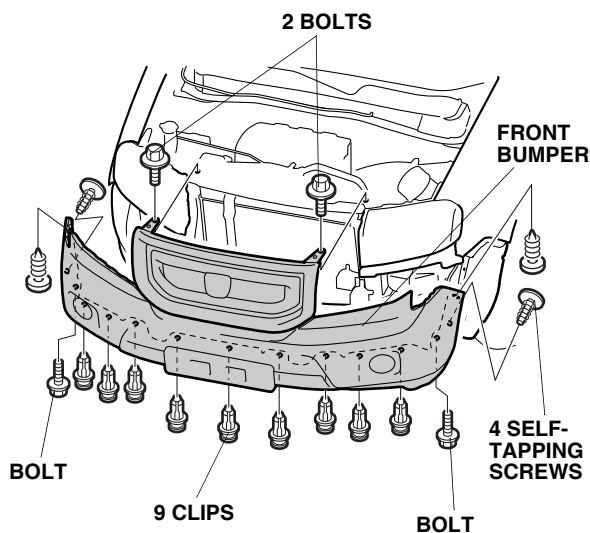

- Using a tape measure, install one wire tie with clip to the heater harness at the measurement shown.

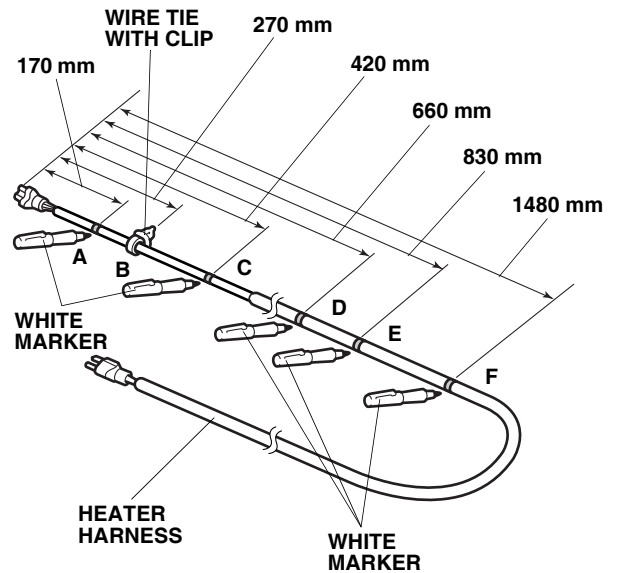

- Using a white marker, mark the heater harness five times, using the measurements shown.

9. Locate and remove the engine block drain bolt and washer. Coolant remaining in the engine jackets flows out of the bolt hole when the bolt is removed. (Retain the bolt and washer in case the block heater is removed.)

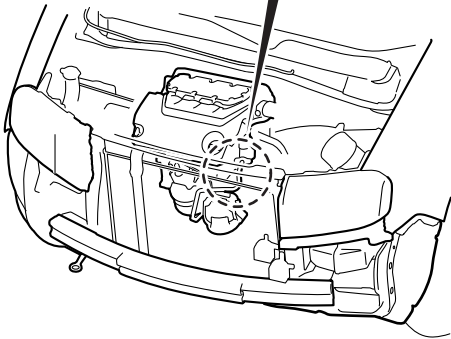
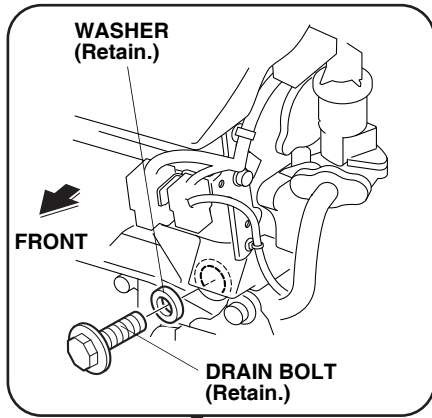

10. Install the engine block heater and aluminum washer into the engine block using a 24 mm socket and a torque wrench. Torque the engine block heater to 60 N·m ( 44 lbf·ft).

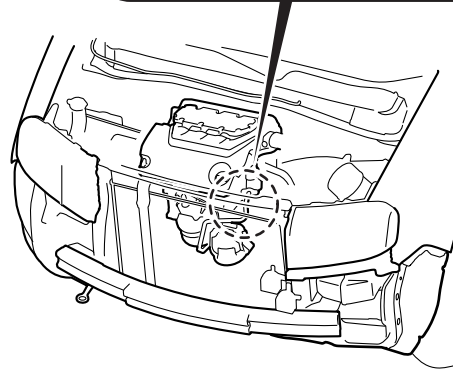
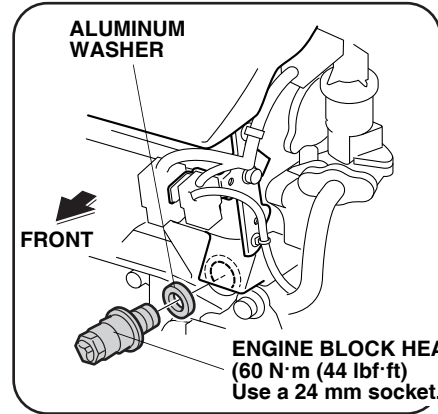

11. Plug the connector end of the heater harness into the engine block heater.

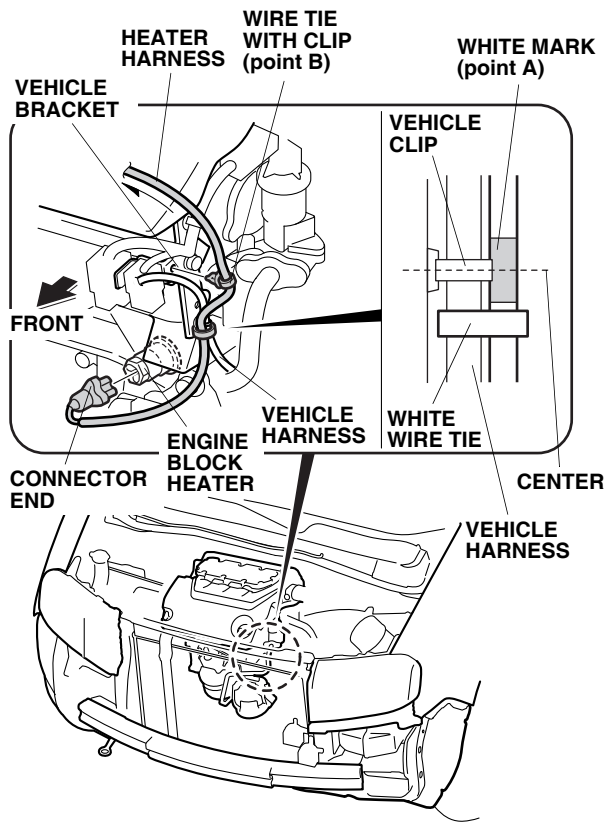

12. Route the heater harness as shown, and secure it to the vehicle harness with one white wire tie (point A). Secure the wire tie with clip (point B) to the vehicle bracket.

13. Route the heater harness as shown, and secure it to the fan shroud rib with one black wire tie (point C).

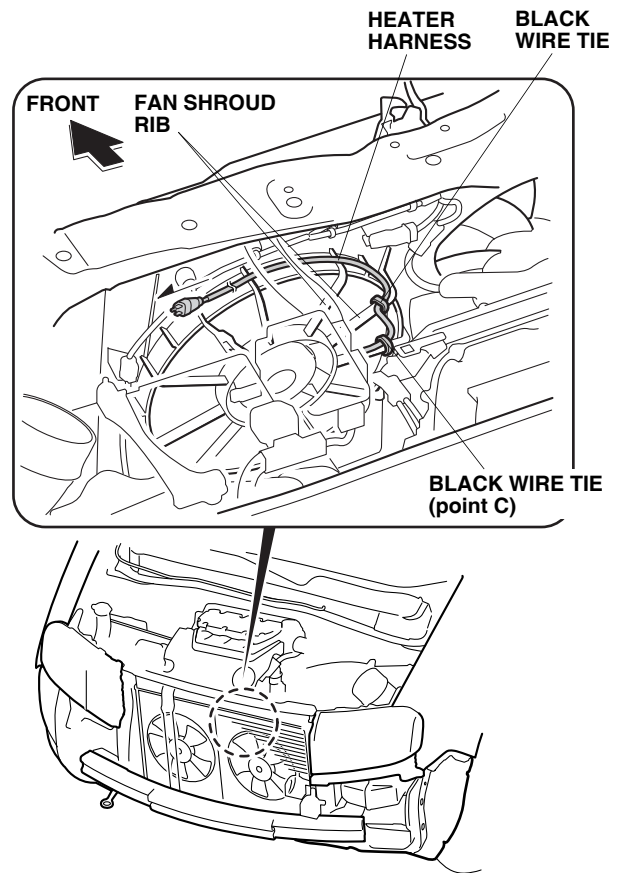

14. Secure the heater harness to the fan shroud rib with one black wire tie.

- Route the heater harness as shown, and secure it to the vehicle harness with two black wire ties (points D, E).

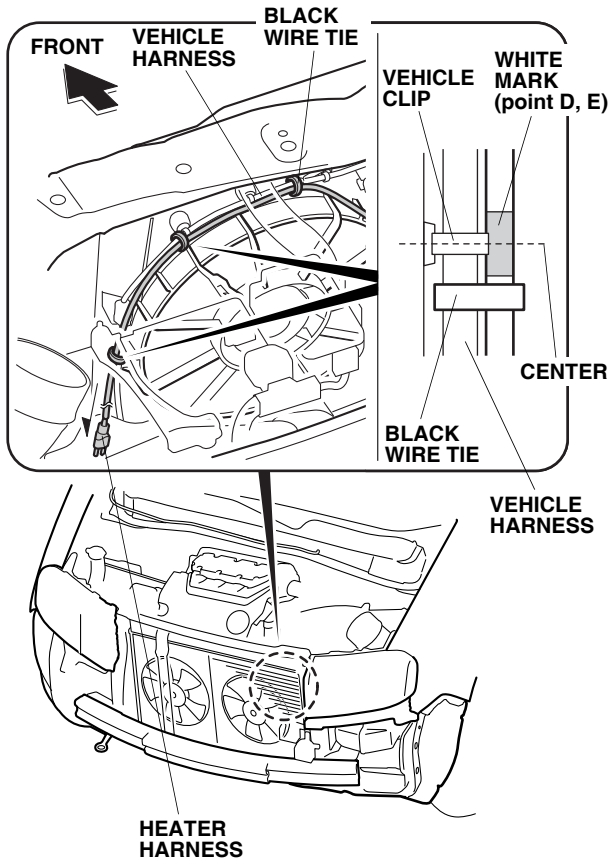

- Secure the heater harness to the vehicle harness with one black wire tie.
- Route the heater harness as shown, and secure it to the vehicle harness with one black wire tie.

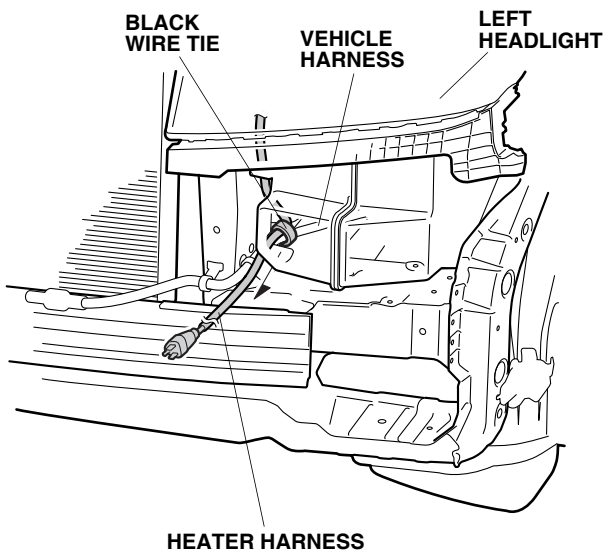

- Route the heater harness as shown, and secure it to the vehicle harness with one black wire tie (point F).

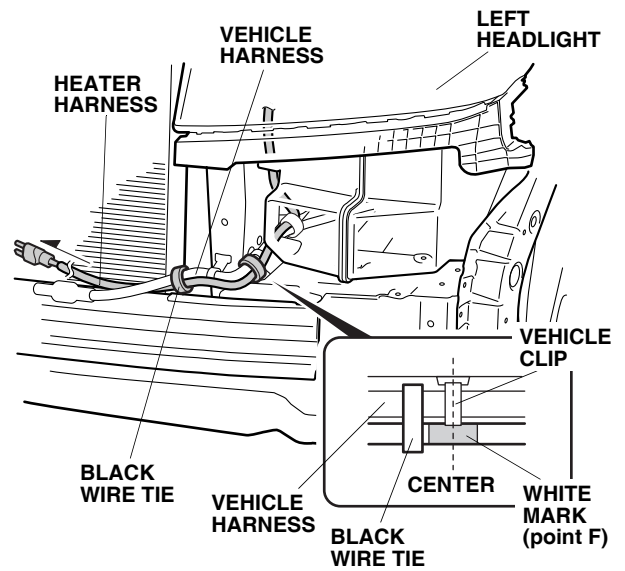

- Secure the heater harness to the vehicle harness with one black wire tie.
- Loosely install the front bumper in the original position.

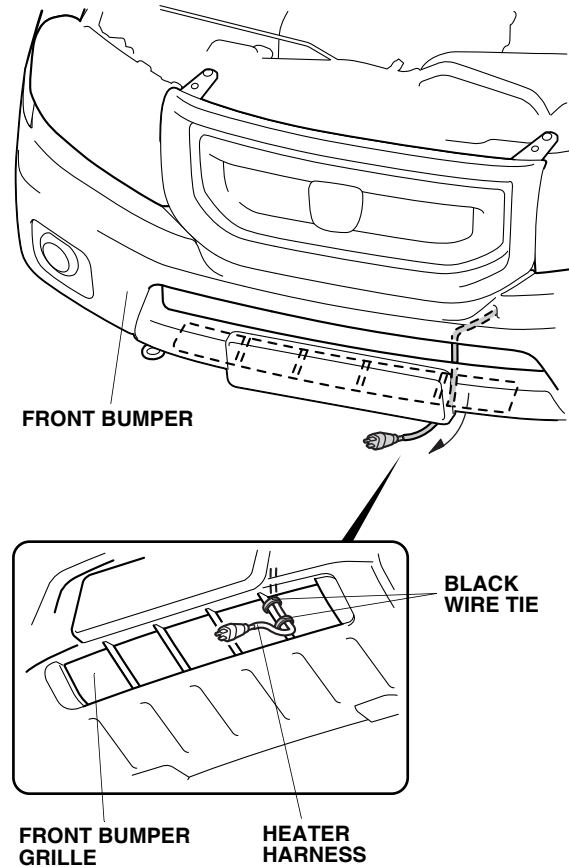

21. Route the heater harness as shown, and secure it to the front bumper grille with two black wire ties.
22. Attach the protective cap to the front bumper grille, and plug the heater harness connector into the protective cap.

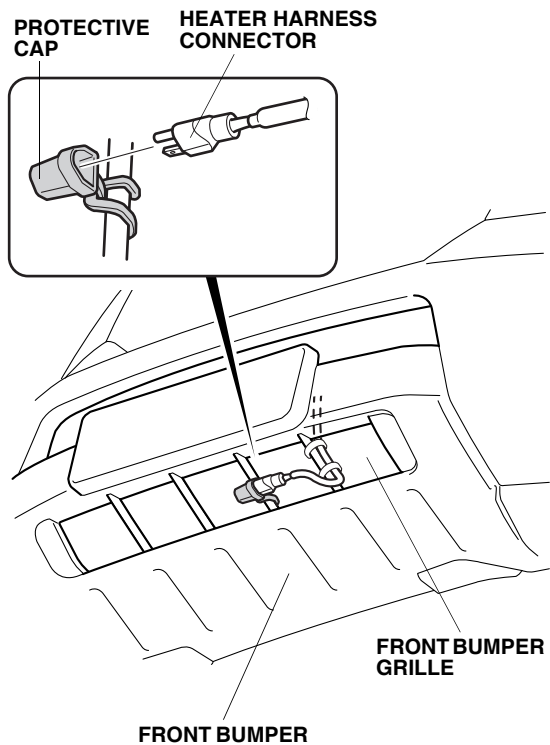

23. Reinstall all removed parts.
24. Reinstall the radiator drain plug.
25. Fill the system with the recommended coolant. Follow the instructions in the service manual to fill and bleed the cooling system.
26. Check the coolant reservoir for correct level and check the cooling system for signs of leakage. Repair as necessary.
27. Check that the heater harness is routed properly and all connectors are plugged in.
28. Put the drain bolt (removed in step 9) in the glove box.
29. Enter the radio anti-theft code, and reset the radio station presets.
30. Reset the clock.