



INSTALLATION INSTRUCTIONS

Accessory
ENGINE BLOCK HEATER
P/N 08T44-SNA-101

Application
2011 ODYSSEY

Publications No.
All 43916
Issue Date
SEP 2010

PARTS LIST

Engine block heater

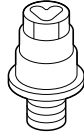

Aluminum washer



Heater harness

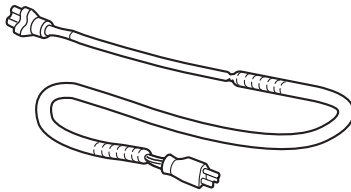

Protective cap

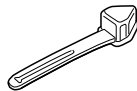

12 Black wire ties
(Some may not used.)

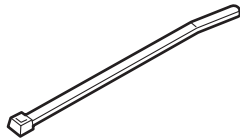

7 Wire ties with clip
(Some may not used.)

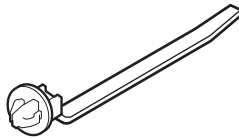

5 White wire ties

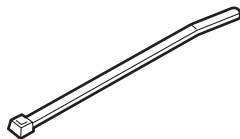

TOOLS AND SUPPLIES REQUIRED

Ratchet

19 mm and 24 mm Sockets

10 mm Open end wrench

Torque wrench

Diagonal cutters

Heavy gloves

Drain pan

Tape measure

White marker

Coolant (Honda All Season Antifreeze/Coolant Type 2)

Fender cover

Phillips screwdriver

Trim Tool Set (SOJATP2014)

(Available through the Honda Tool and Equipment program. On the iN, click on: Service/Service Bay/Tool and Equipment Program, then enter the number under "Search." Or call 888-424-6857.)

Tape

Blanket

Drill

3 mm and 5 mm Drill bits

File

Eye protection

Tape measure

Pushpin

Illustration of the Engine Block Heater Installed on the Vehicle

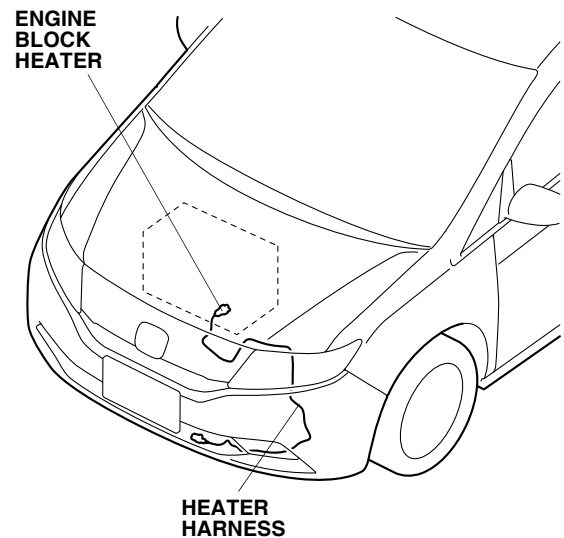

INSTALLATION

NOTE:

- Always use, Honda All Season Antifreeze/Coolant Type 2. Using a non-Honda coolant may result in corrosion, causing the cooling system to malfunction or fail.
- To avoid burning out the element, do not operate the engine block heater before it is installed on the vehicle and before you add the coolant.

Customer Information: The information in this installation instruction is intended for use only by skilled technicians who have the proper tools, equipment, and training to correctly and safely add equipment to your vehicle. These procedures should not be attempted by “do-it-yourselfers.”

1. Allow the engine and all cooling system components to cool down
2. Make sure you have the anti-theft code for the radio unit and navigation system (if equipped), then write down the radio station presets.
3. Remove the air duct (two clips).

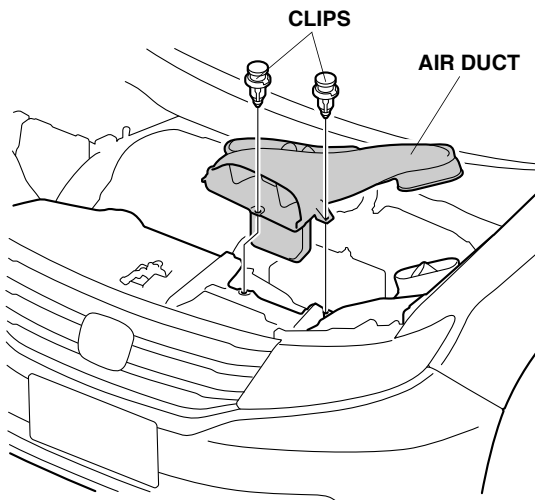

4. Remove the front grille cover (seven clips).

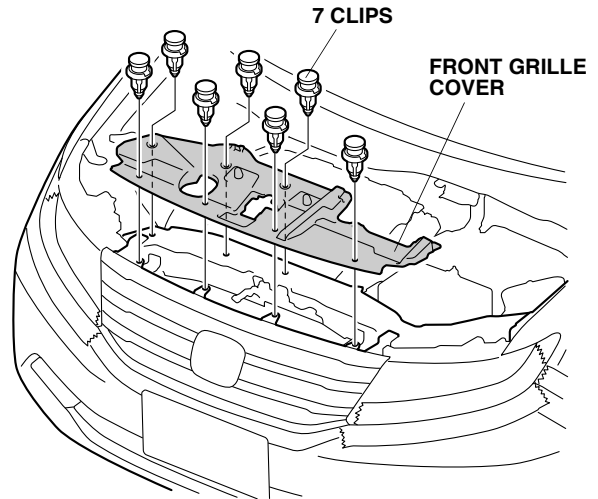

5. Disconnect the negative cable from the battery.
6. Place a clean drain pan under the radiator drain plug, then remove the drain plug from the bottom of the radiator to drain the coolant. Remove the radiator cap to increase the flow.

NOTICE: Radiator coolant will damage the body paint. Quickly rinse any spilled coolant from the body paint finish.

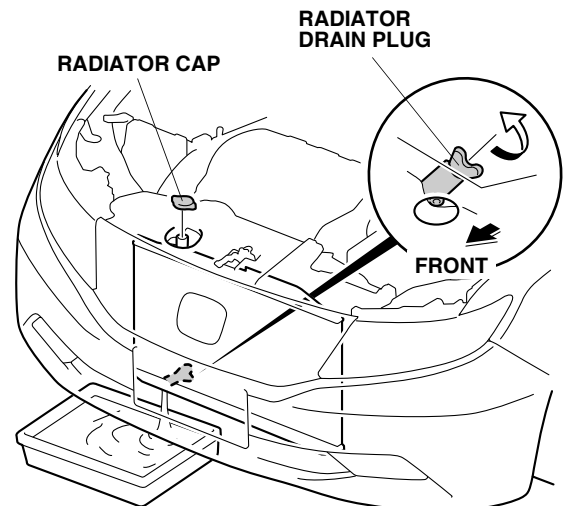

7. Remove the front bumper.
 - On each side of the bumper, attach masking tape to the areas shown.

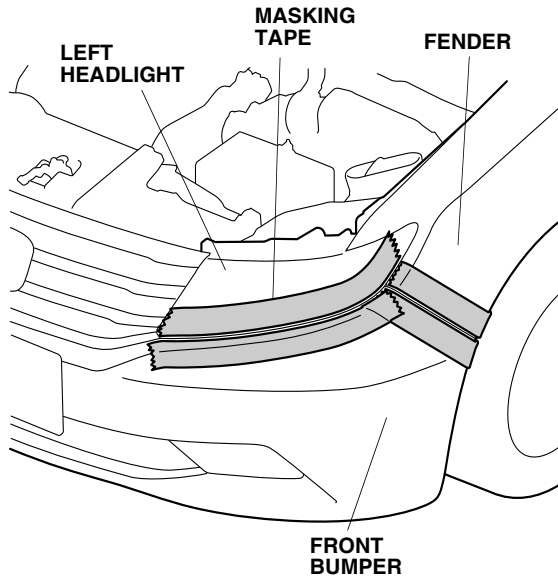

- On each side, release eight retaining tabs from the front bumper.

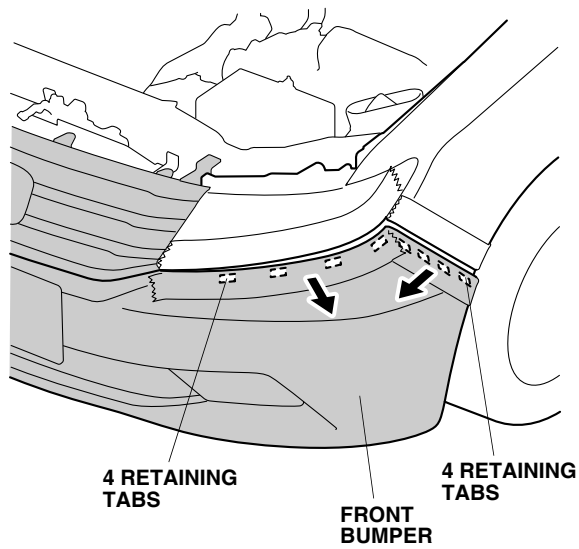

- Remove four self-tapping screws, eight bolts, and the four clips from the front bumper.

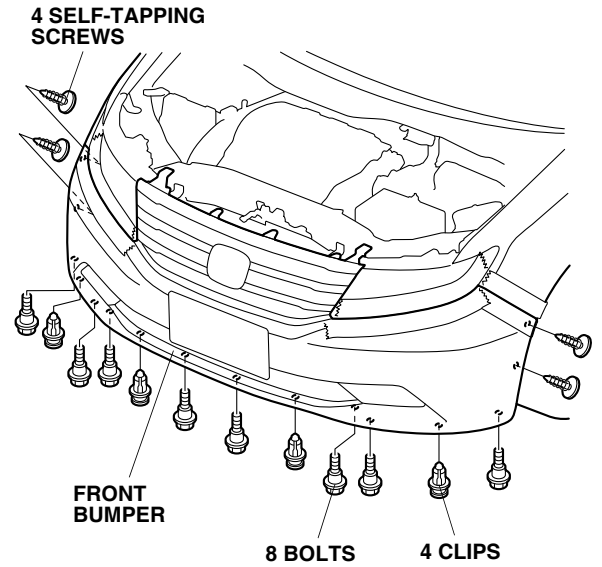

- Remove two top bolts from the front bumper. With the help of an assistant, remove the front bumper.

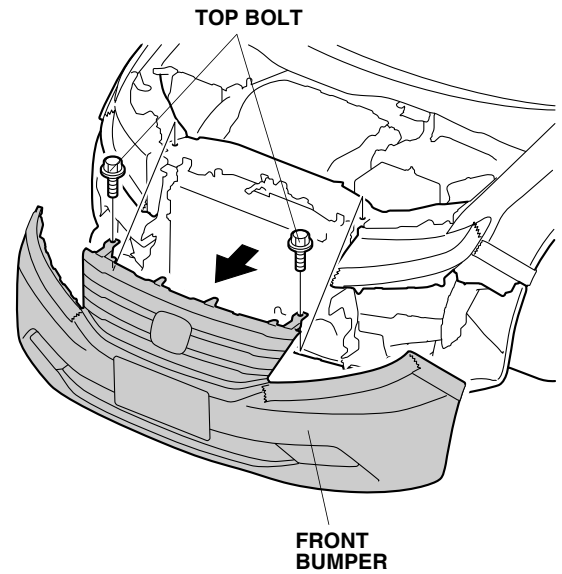

- Place the front bumper on a blanket.

- Open the positive cable cover, and disconnect the positive (+) battery cable from the battery. Unfasten two battery holder nuts, and remove the battery holder.

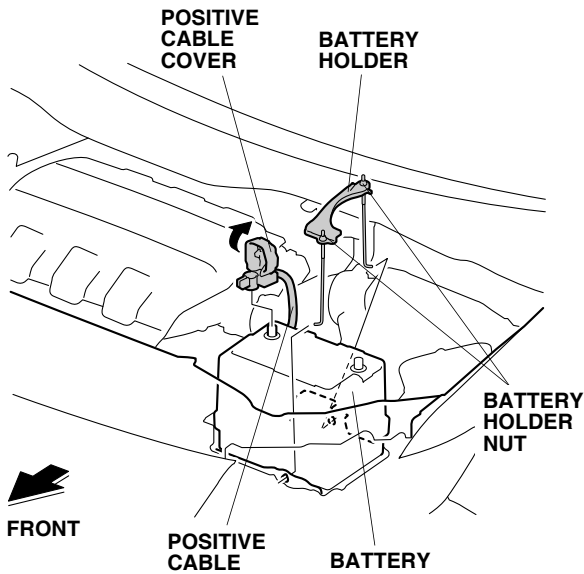

- Remove the battery cover, battery, and battery tray.

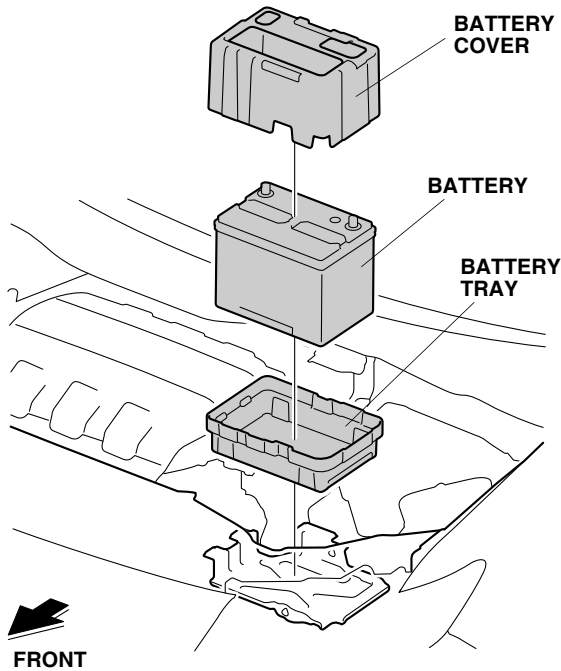

- Get the heater harness. Using a tape measure, install one wire tie with clip to the heater harness as shown.

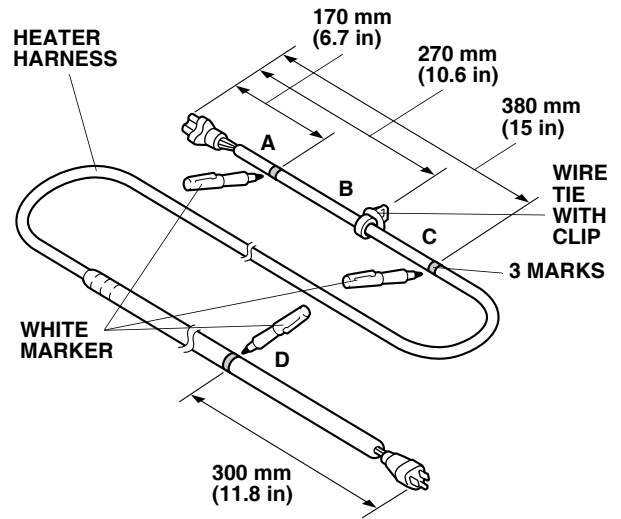

- Using a white marker and a tape measure, mark the heater harness at three positions as shown.
- Locate and remove one drain bolt and one washer from the front of the engine block using a 19 mm socket. Coolant remaining in the engine jackets will flow out of the bolt hole when the bolt is removed. (Retain the bolt, it will be used if engine block heater is removed.)

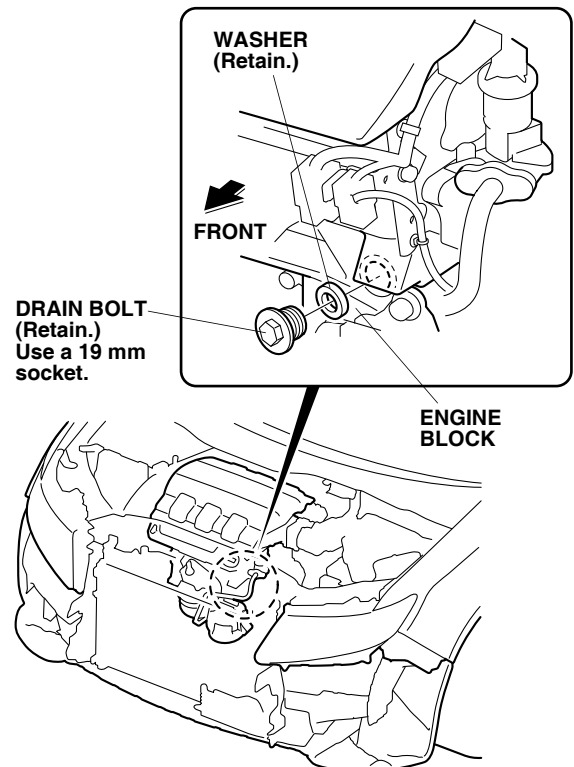

- Install the engine block heater with the aluminum washer into the bolt hole using a 24 mm socket. Torque the engine block heater to 60 N·m (44 lbf·ft).

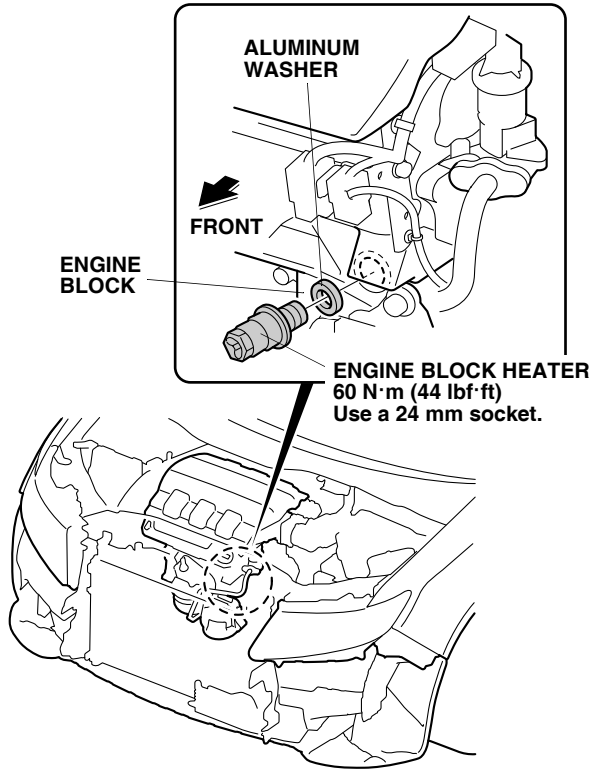

- Plug the connector end of the heater harness into the engine block heater.

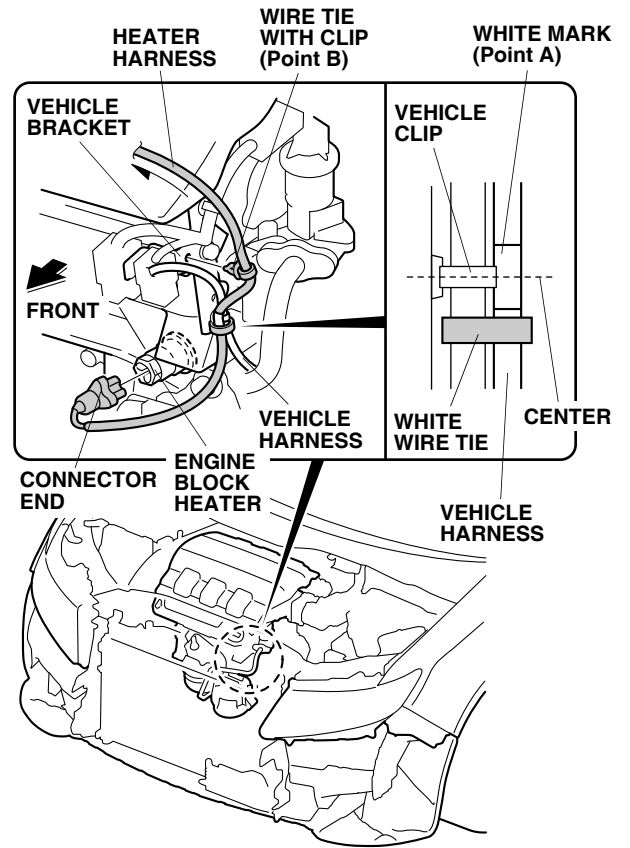

- Route the heater harness in the direction shown, and secure it to the vehicle harness with one white wire tie (point A). Secure one wire tie with clip (point B) to the vehicle bracket.

16. Route the heater harness as shown, and secure it to the fan shroud rib with one white wire tie (point C).

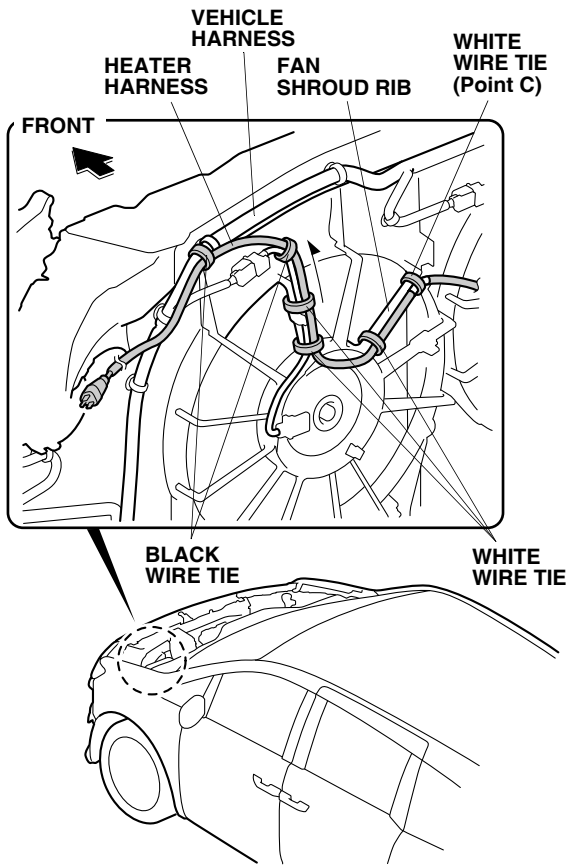

18. Continue routing the heater harness along the vehicle harness, and secure it to the vehicle harness with four black wire ties.

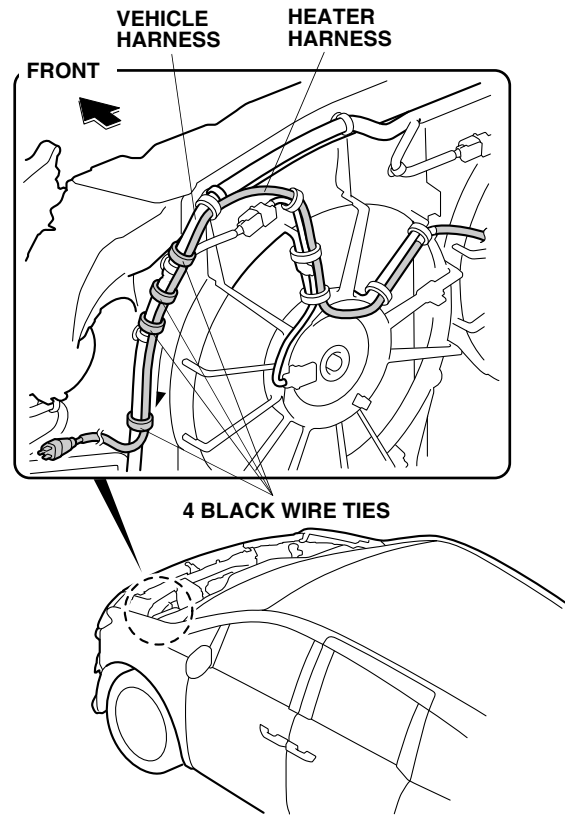

17. Route the heater harness along the vehicle harness as shown, and secure it to the fan shroud rib with three white wire ties. Secure the heater harness to the vehicle harness with two black wire ties.

19. Using a pushpin, pierce the air guide as shown.

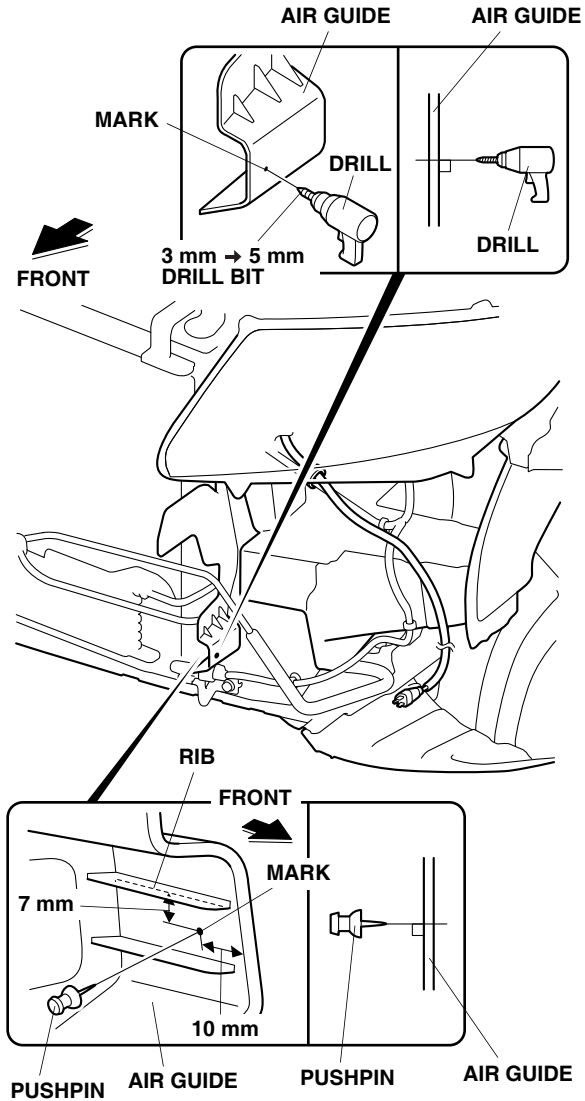

20. While wearing an eye protection, drill the pierced mark to 5 mm. First drill with a 3 mm drill bit, and finish with a 5 mm drill bit. Remove any burrs.

21. Using a diagonal cutter, cut the air guide using the measurement shown.

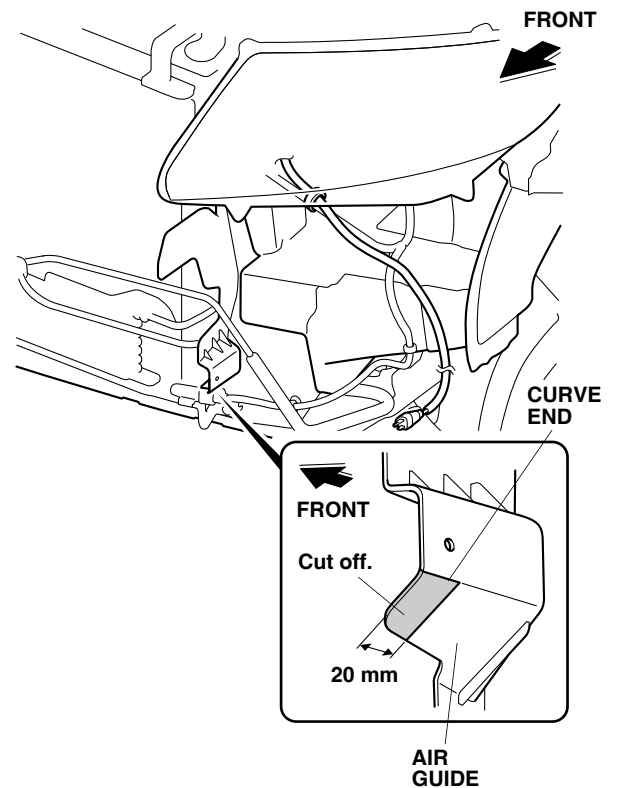

22. Route the heater harness down under the left headlight and forward.

EX, EX-L Model: Secure the heater harness to the vehicle harness with five black wire ties.

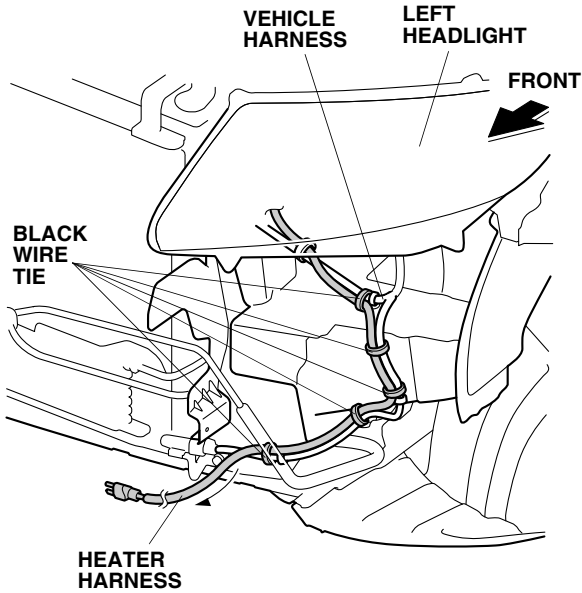

LX Model: Secure the heater harness to the vehicle harness with one black wire tie, and three wire ties with clip.

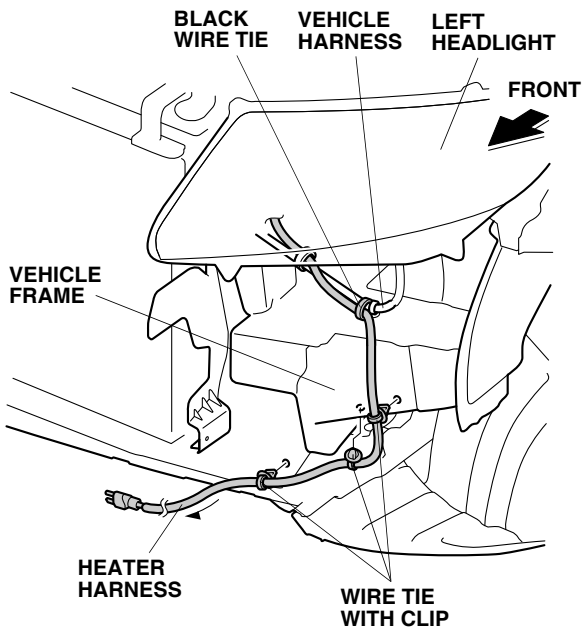

23. Install the heater harness to the hole made in step 20 with one black wire tie (point D).

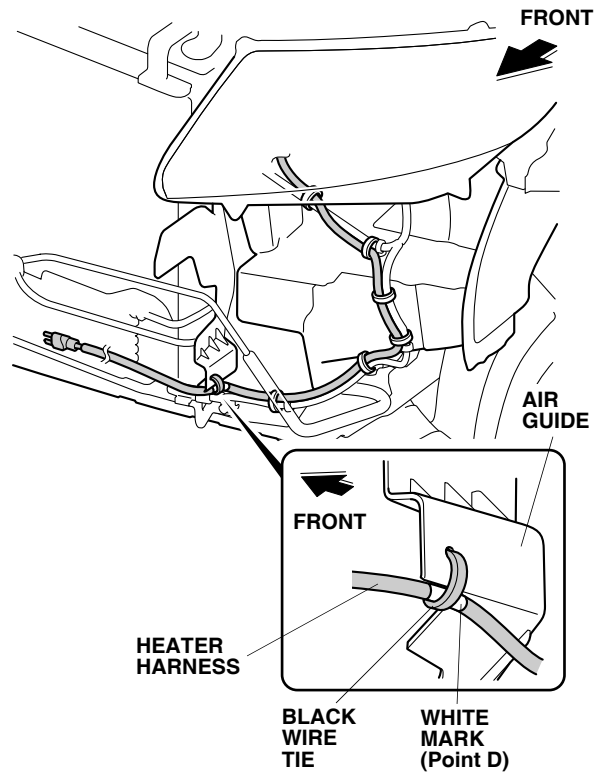

24. With the help of an assistant, route the heater harness through the front bumper in the area shown, then reinstall the front bumper.

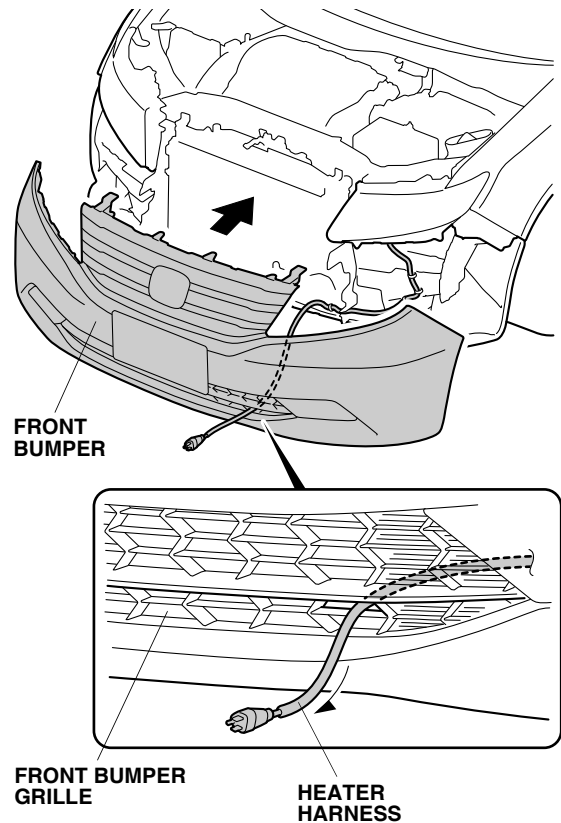

25. Attach the protective cap to the front bumper grille, and plug the heater harness connector into the protective cap.

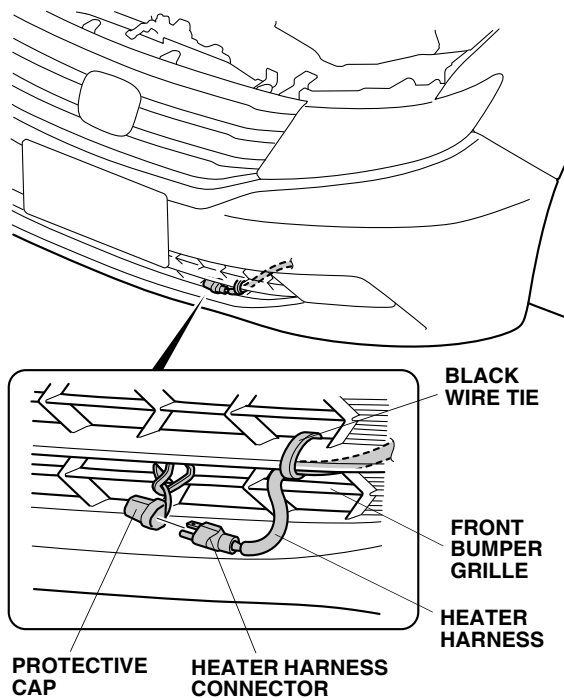

26. Secure the heater harness to the front bumper grille with one black wire tie.

27. Reinstall all removed parts, except for the radiator cap.
28. Fill the system with the recommended coolant. Follow the instructions described in the service manual to fill and bleed the cooling system.
29. Check the coolant reservoir for correct level and check the cooling system for signs of leakage. Repair as necessary.
30. Check that the heater harness is routed properly and all connectors are plugged in.
31. Store the drain bolt (removed in step 12) in the glove box.
32. Enter the radio anti-theft code for the audio unit and navigation system (if equipped), and reset the radio station presets.
33. Reset the clock.