

PARTS LIST

Moonroof visor

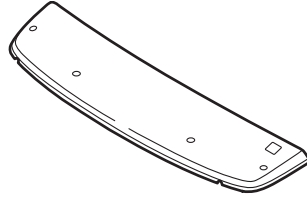

2 Front brackets

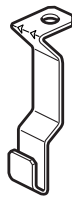

2 Side brackets

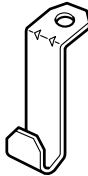

4 Screws



4 Nuts



4 Protective tapes

**TOOLS AND SUPPLIES REQUIRED**

Phillips screwdriver

10 mm Combination wrench

Scale

Isopropyl alcohol

3 Shop towels

Masking tape

Felt-tip pen

Torque wrench

INSTALLATION

1. Clean the roof area to be covered, and wax the area with a high-quality paste wax.
2. Open the moonroof.
3. Roll up two shop towels and insert them between the roof panel and air deflector to lower the air deflector. Take care not to damage the air deflector.

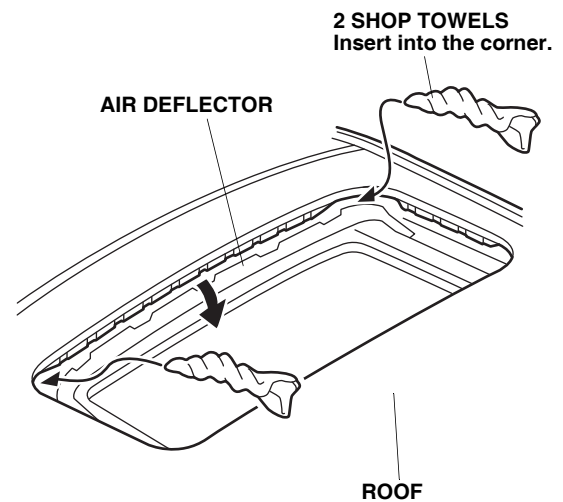

- At the right front corner of the moonroof opening, measure along the rise from the flange end of the opening approximately 50 mm as shown and mark with a felt-tip pen.

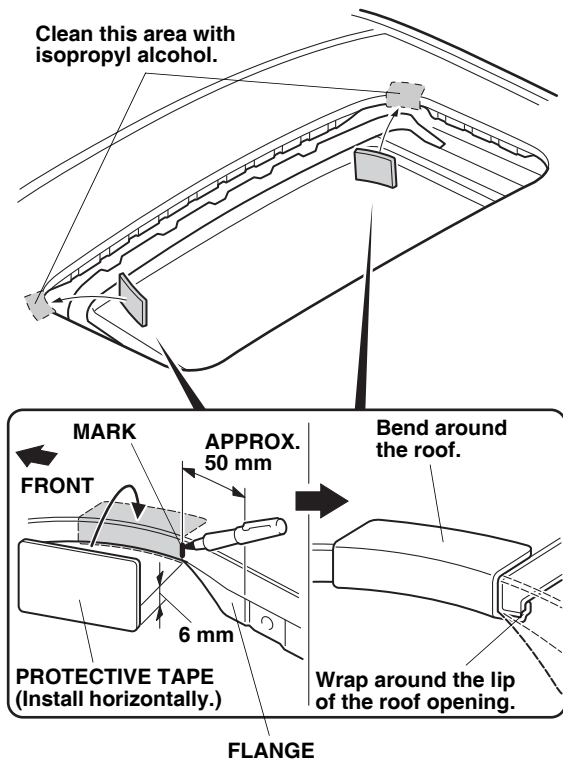

- Using isopropyl alcohol on a shop towel, clean the roof area and the inside edge of the moonroof opening. Starting at the mark you made, clean about 2 inches toward the front of the opening but don't wipe off the mark.
- Remove the adhesive backing from one protective tape, and align the tape with the mark you made in step 4. Wrap the bottom of the tape 6 mm around the bottom lip of the moonroof opening as shown. Then wrap the tape around to the top of the roof panel.

- Repeat steps 4 thru 6 to install the protective tape on the left side of the moonroof opening. Remove the marks you made using isopropyl alcohol on a shop towel.
- Locate the indentations shown. Using isopropyl alcohol on a shop towel, clean the roof area where the protective tape will attach.

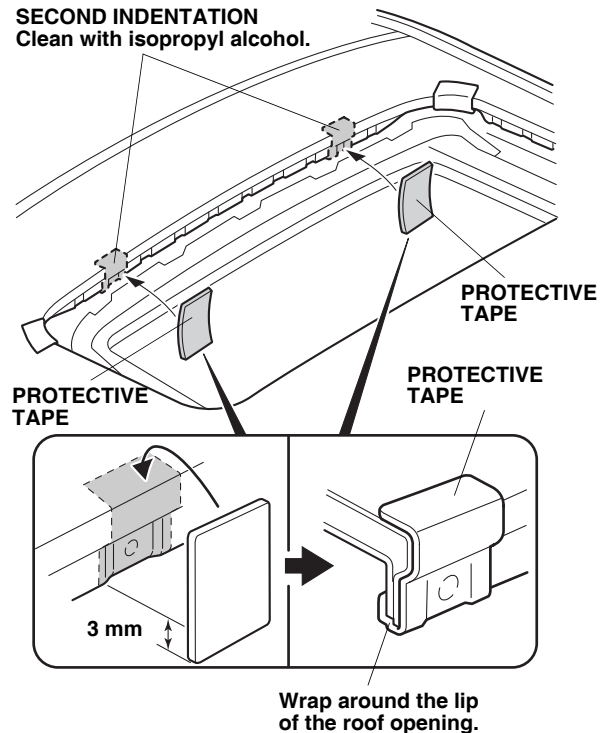

- Install the protective tape at the second indentations in from the outside of the moonroof opening. Remove the adhesive backing from the protective tape and attach one at each position. Wrap 3 mm of protective tape around the lip of the moonroof opening.
- Place the two front brackets into position as shown, and tape them in place with masking tape.

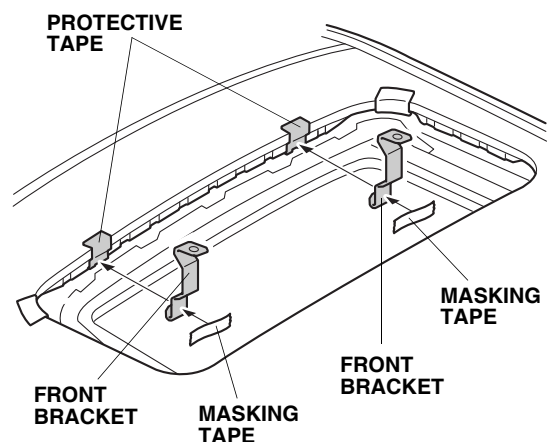

11. Install the two brackets to the moonroof visor, using two screws and two nuts. Do not tighten the two screws and two nuts yet.

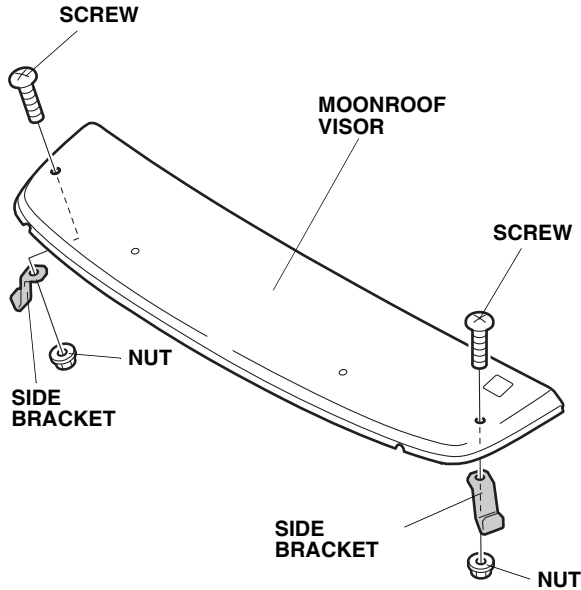

12. Align the moonroof visor on the roof and attach the side brackets over the center of the protective tapes. Do not tighten the two screws and two nuts yet.

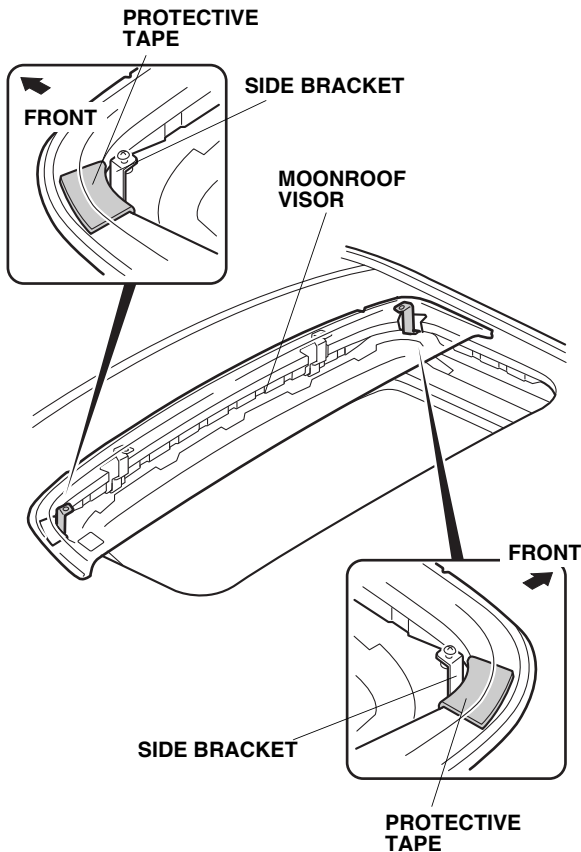

13. Align the holes in the moonroof visor with the holes in the front brackets and install the two screws and two nuts. Do not tighten the two screws and two nuts yet. Remove the masking tape.

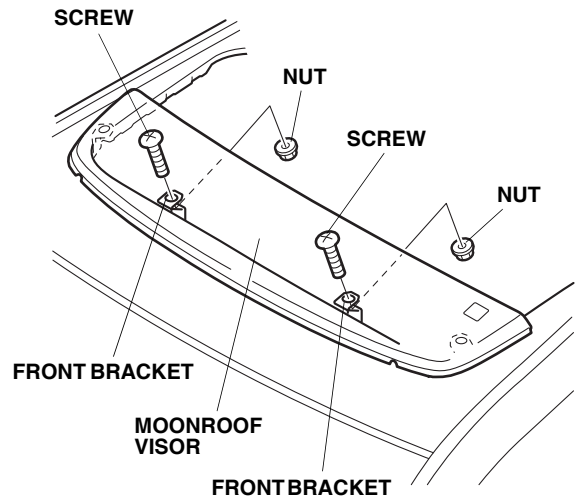

14. Position the moonroof visor with equal spacing on all sides. Check that the rubber seal is not twisted or rolled under the visor.

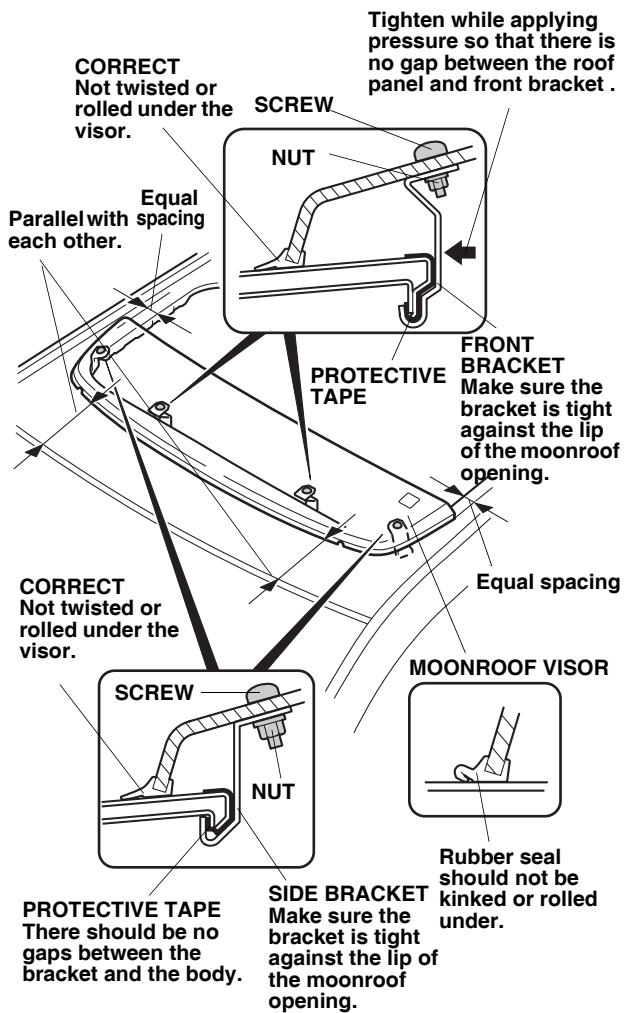

15. Tighten the two screws and two nuts on the front of the visor first, then tighten the two screws and two nuts on the right and left sides of the visor. Tighten while applying pressure so that there is no gap between the roof panel and the front/side bracket. Front/Side brackets tightening torque: 2 N·m (1.5 lb-ft)

16. Remove the IMPORTANT INFORMATION label.

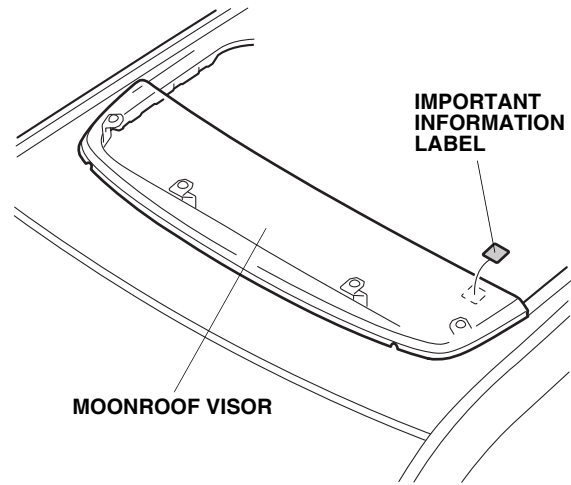

CARE OF THE MOONROOF VISOR

- To avoid damaging the surface, never use ammonia-based cleaners or solvents to clean the moonroof visor.
- Clean with a solution of mild dishwashing soap and water using a soft cloth or chamois.
- To remove fine scratches and restore the original luster, use Meguiar's Mirror Glaze plastic cleaner and polish or an equivalent high-quality plastic cleaner.