



INSTALLATION INSTRUCTIONS

Accessory
19" ALUMINUM WHEEL
P/N 08W19-TE0-102

Application
2011 ACCORD
2-DOOR

Publications No.
All 43999

Issue Date
AUG 2010

PARTS LIST

Aluminum wheel
(The illustration may differ from the actual wheel.)

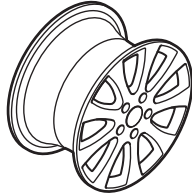

Wheel center cap
(The illustration may differ from the actual center cap.)

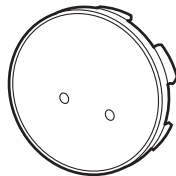

Center cap emblem



2 Push nuts



Tire pressure information label



TPMS Information
(Give this information to your customer.)

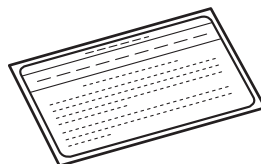

Supplemental information

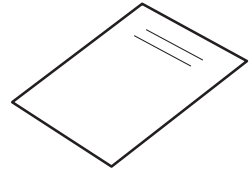

Parts for TPMS sensor assembly

Tire pressure sensor

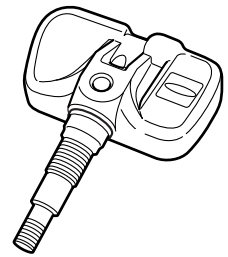

Washer



Valve cap

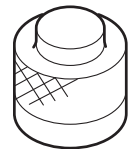

Valve nut



TOOLS AND SUPPLIES REQUIRED

Ratchet

11 mm Socket

Torque wrench

Isopropyl alcohol

Shop towel

HDS

TPMS Trigger Tool (T/N AEQVT55)

(Available through the American Honda Tool and Equipment Program: call (888) 424-6857)

SPECIFICATIONS

Rim size	19 x 8 J (inset 55)	
Tire size	245/40R19 94W	
Bolt hole PCD	114.3 (5 holes)	
Tire pressure	Front	250 kPa (2.5 kgf/cm ² , 36 psi)
	Rear	250 kPa (2.5 kgf/cm ² , 36 psi)

INSTALLATION

Customer Information: The information in this installation instruction is intended for use only by skilled technicians who have the proper tools, equipment, and training to correctly and safely add equipment to your vehicle. These procedures should not be attempted by “do-it-yourselfers.”

NOTE:

- This aluminum wheel is designed for use on vehicles equipped with TPMS (Tire Pressure Monitoring System).
- This aluminum wheel is equipped with a TPMS sensor. See the service manual for the tire replacement procedure and the TPMS sensor installation procedure.
- The illustration of the aluminum wheels are shown for reference purposes only.
- Install the correct size tire.
- Follow the instructions in the owner's manual when jacking up the vehicle and removing and installing the wheels. Do not overtighten the wheel nuts by placing your weight on the wrench or by using a pipe for added leverage.
Wheel nut torque: 108 N·m (11 kgf·m, 80 lbf·ft).
- Use a tire changer to install and remove the tires as described in the operation manual furnished with the tire changer. Do not use a tire lever to install and remove the tires as it may cause damage to the tire and aluminum wheel.
- Be careful not to damage the wheel center cap when installing the emblems.
- This center cap emblem should be installed only if the ambient air temperature is 60°F (15°C) or above.
- To allow the adhesive to cure, do not wash the vehicle for 24 hours. Please advise the customer.

1. Using isopropyl alcohol on a shop towel, thoroughly clean the area where the center cap emblem will attach.

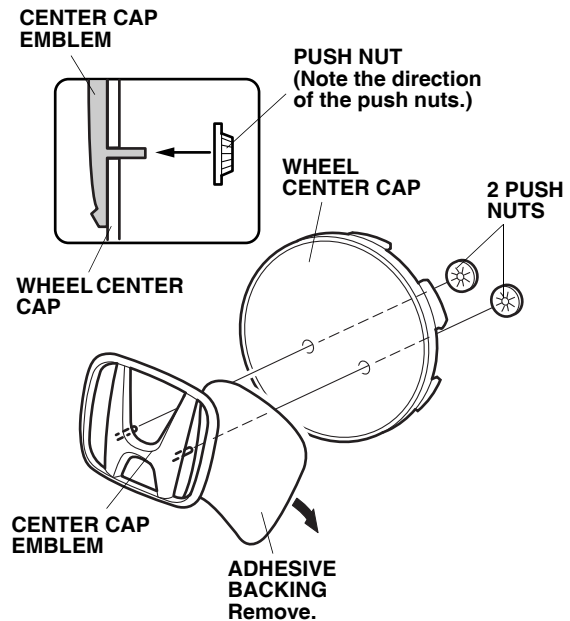

2. Remove the adhesive backing from the center cap emblem.
3. Align the pins with the holes, and attach the center cap emblem to the wheel center cap. After attaching, hold the emblem firmly against the wheel center cap with the palm of your hand for 30 seconds.
4. Slide the push nuts onto the pins. Note the direction of the push nuts.

- Before installing the tire pressure sensor, clean the mating surfaces on the sensor and the aluminum wheel.

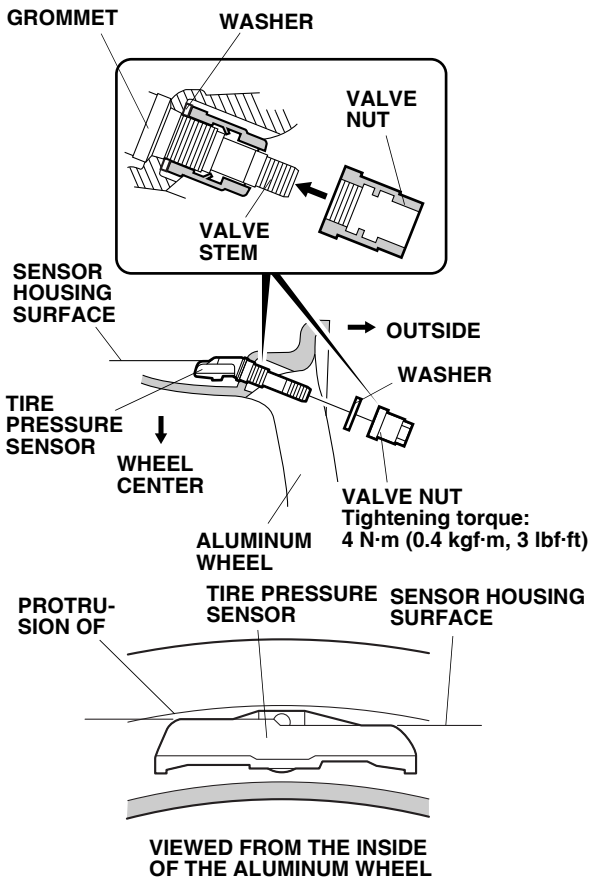

- Install the tire pressure sensor and the washer to the aluminum wheel, and finger-tighten the valve nut. Make sure the pressure sensor is resting on the wheel.
 - Tighten the valve nut to the specified torque while holding the tire pressure sensor against the wheel. Tightening torque: 4 N·m (0.4 kgf·m, 3 lbf·ft)
- NOTE:**

- To prevent the sensor housing from being caught on the bead when mounting the tire, install the tire pressure sensor so that the sensor housing surface does not protrude into the bead area of wheel.
- Do not reuse any grommet that has been tightened, even one time, to the specified torque, as it is deformed inside.
- Do not use pneumatic or electric tools on the valve nut.
- Tightening the nut over the specified torque can damage the grommet.

- Install the tires according to the instructions in the service manual.
- Install the wheels on the vehicle and torque the wheel nuts to 108 N·m (11 kgf·m, 80 lbf·ft).

MEMORIZING THE TIRE PRESSURE SENSOR ID

- Using the HDS and TPMS trigger tool, memorize the tire pressure sensor ID according to the instructions in the service manual (Memorizing the Tire Pressure Sensor ID).

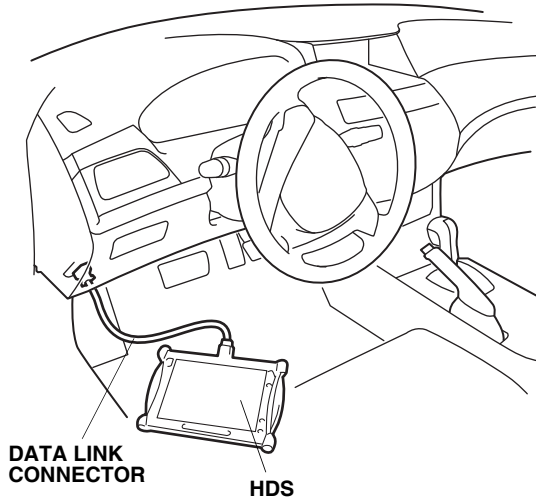

DATA LINK CONNECTOR

HDS

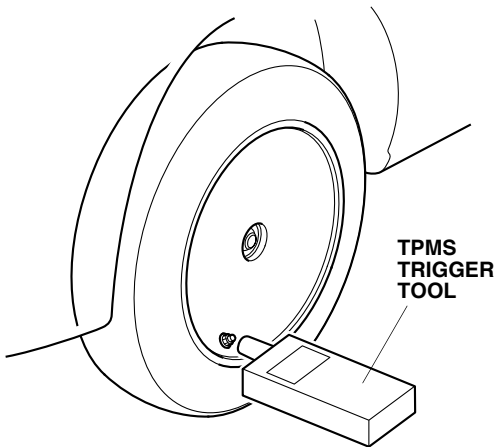

TPMS TRIGGER TOOL

- Open the driver's door. Using isopropyl alcohol on a shop towel, thoroughly clean the area where the Tire Pressure Information Label will attach. Remove the adhesive backing from the label and attach it over the standard tire pressure information label as shown.

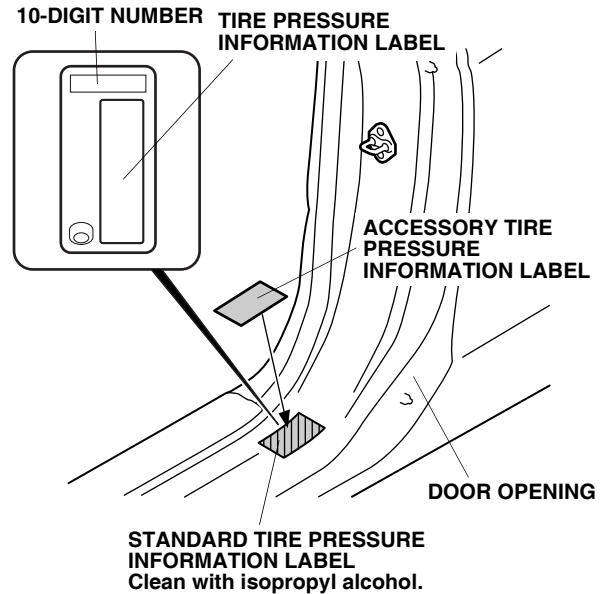

- Attach the "Supplemental Information" page included in this kit into the owner's manual. Follow the instructions attached to the "Supplemental Information" page.
- Perform the Inch-up Tire Pressure programming procedure on the next page.
- After finishing the work, write the tire size, tire pressure, HDS version, dealer name, technician's signature and date in the "Service History Page for Honda Accessory Alloy Wheels" page included in this kit and attach it to the vehicle's service history booklet.

- Be sure to explain the contents of the "Supplemental Information" when delivering the vehicle to your customer.
- Be sure to give the TPMS information to your customer.

INCH-UP TIRE PRESSURE PROGRAMMING (LOW AIR PRESSURE WARNING THRESHOLD REPROGRAMMING)

1. After the sensor ID learning using the HDS, back up to the “TPMS Mode Menu”, and click on “Threshold Rewriting.”
2. Select “Reprogramming for accessory tires.”
3. When the HDS says, “Do you want to rewrite the threshold data?” click “YES.”
4. Check that “Please enter the tire information code of new tires” is shown, and click the “Keyboard” icon.
5. Enter the 10-digit tire information code printed on the new tire pressure information label, then click the check icon.
6. Check that the tire pressure shown on HDS, and the new tire pressure on the tire information label are the same, then click the “YES” button.
7. Check that the current air pressure setting shown on HDS is correct and “Reprogramming the threshold data for non-standard tires has completed successfully” is shown.
8. After programming, write the tire pressure indicated on the HDS in the “Service History Page for Honda Accessory Alloy Wheels”, then click the check icon.
9. After programming, sign on the “Service History Page for Honda Accessory Alloy Wheels”, according to the procedure on page 6.

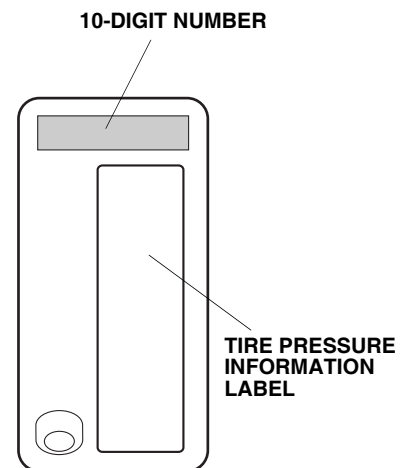
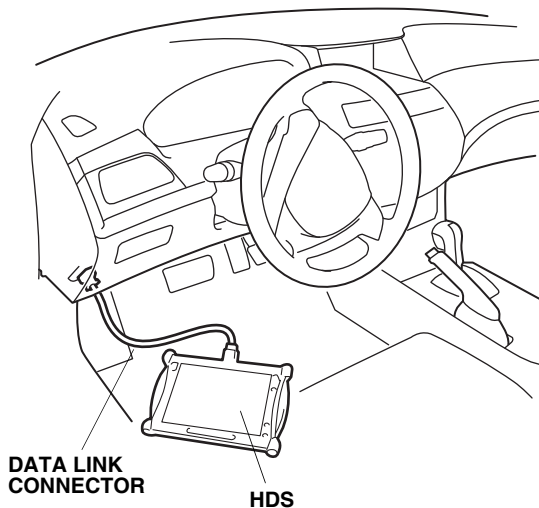

TPMS CONTROL UNIT REPLACEMENT

If the TPMS control unit is ever replaced and the vehicle has inch-up wheels, the low pressure sensor threshold must be changed. Once the TPMS control unit is installed, follow steps 10 to 14 (which includes memorizing ID and programming for accessory tires).

STANDARD TIRE PRESSURE PROGRAMMING

If the original equipment (standard) tires are to be installed back on the vehicle, memorize the tire pressure sensor ID and change the low pressure warning threshold.

NOTE: Have the standard tire pressure label on hand.

1. Install the standard tires, and memorize the tire pressure sensor IDs according to the instructions in Service Manual.
2. Change the tire pressure programming (the low air pressure warning threshold):
 1. Connect the HDS to the vehicle, make sure the correct VIN is populated, and enter the mileage.
 2. At the "System Selection Menu," click "TPMS."
 3. At the "Mode Menu", click on "DTCs" and clear any stored codes.
 4. Go back to the "Mode Menu," and click on "Threshold Rewriting."
 5. Click on "Reprogramming for standard tires," and follow the screen prompts.
 6. After programming, write the standard tire pressure in the supplemental information, then click the check button.
 7. Attach the tire pressure information label for standard tires at the prescribed location.
 8. After programming, write the following information on the "Service History Page for Honda Accessory Alloy Wheels."

Write the tire size, tire pressure, HDS version, dealer name, technician's signature and date in the "Service History Page for Honda Accessory Alloy Wheels" page attached to the vehicle's service history booklet.

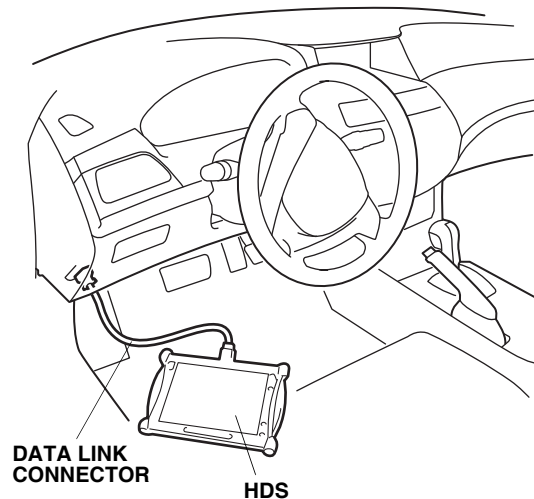

THRESHOLD DATA CHECK

If for some reason you are unsure of where the low pressure warning threshold is set, it can be checked by using the Threshold Data Check.

Check the TPMS programming of the pressure on the vehicle:

1. Connect the HDS to the vehicle, make sure the correct VIN is populated, and enter the mileage.
2. At the "System Selection Menu," click "TPMS."
3. Click on "Threshold Rewriting."
4. Click on "Threshold Data Check."

