



INSTALLATION INSTRUCTIONS

Accessory

TONNEAU COVER
P/N 08Z07-SJC-100

Application

2010 RIDGELINE

Publications No.

All 42160

Issue Date

AUG 2009

PARTS LIST

Tonneau cover

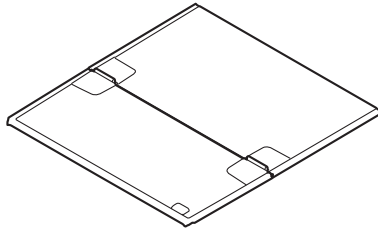

4 Brackets

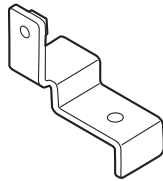

6 Clips

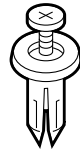

Washer



4 Plate nuts



8 Washer-bolts, 6 x 14 mm



4 Washer-bolts, 6 x 20 mm

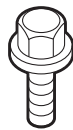

6 Rubber guides



Left seal



Right seal



4 Rubber grommets



Left rail cap

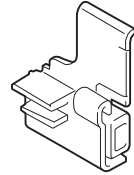

Right rail cap

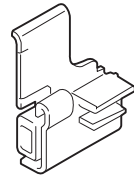

Left rail
(four holes)

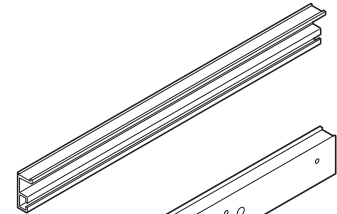

Right rail
(five holes)

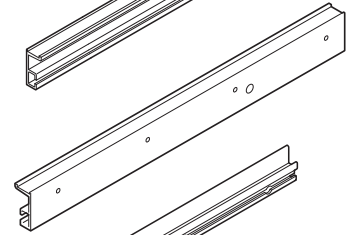

Front bed panel rail

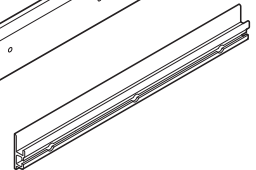

2 Brackets A

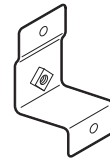

Bracket B

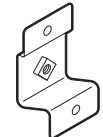

2 Brackets C

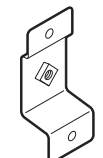

2 Brackets D

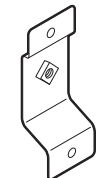

3 Collars



3 Long flange bolts

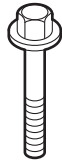

16 Short flange bolts



8 Bumper bolts



7 Clips



Circle grommet



6 Ellipse grommets



Lock bracket

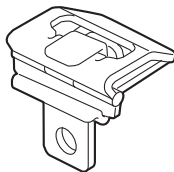

2 Keys



2 Cushion tapes

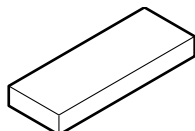

TOOLS AND SUPPLIES REQUIRED

Phillips screwdriver

Flat-tip screwdriver

Ratchet

10 mm Socket

T40 and T50 Torx wrench

Drill

3 mm, 6 mm, and 10 mm Bit

Unibit (step drill)

15 mm and 25 mm Holesaw

Hacksaw blade

Utility knife

File

Eye protection (face shield, safety goggles, etc.)

Scale

Isopropyl alcohol

Shop towel

Rubber mallet

Measure

Hard plastic plate (approx. 50 mm x 80 mm x 1 mm)

Felt-tip pen

KTC trim tool set (SOJAT P201H)

INSTALLATION

Customer Information: The information in this installation instruction is intended for use only by skilled technicians who have the proper tools, equipment, and training to correctly and safely add equipment to your vehicle. These procedures should not be attempted by "do-it-yourselfers."

NOTE: Be careful not to damage the body finish.

1. Make sure you have the anti-theft code for the radio, then write down the radio station presets.
2. Disconnect the negative cable from the battery.
3. Remove the left front upper tie-down hook (two torx bolts). Remove the right front upper tie-down hook (two torx bolts).

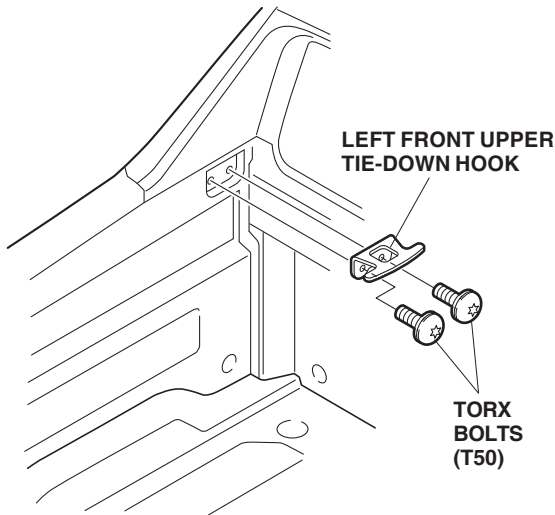

4. Remove the front bed panel (six torx bolts).

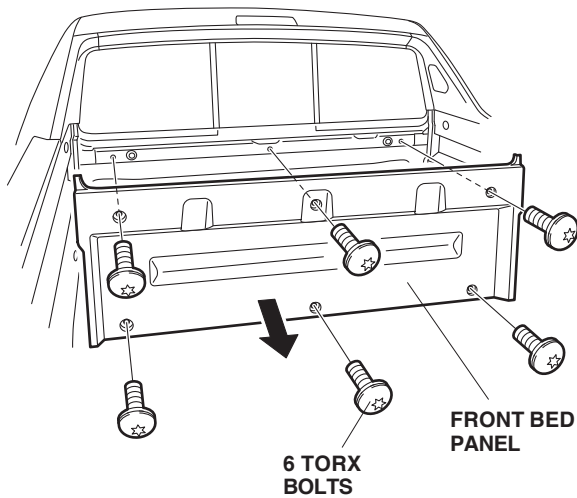

5. While wearing eye protection, enlarge the three upper holes in the front bed panel using a 1 in. (25 mm) step drill. Remove all burrs from the edges of the holes with a file.

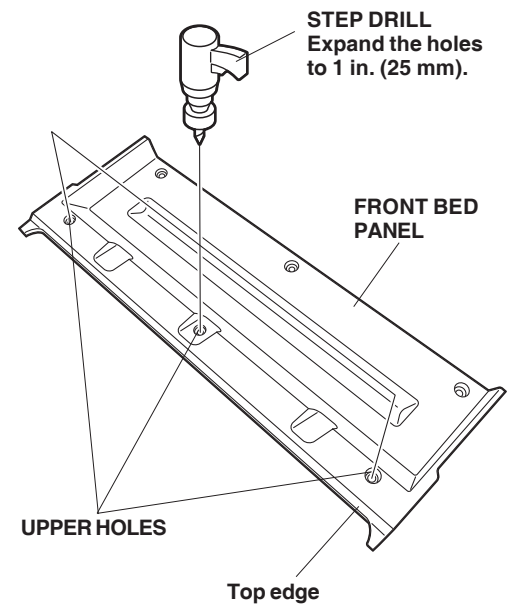

6. While wearing eye protection, drill a 3 mm hole through eight marked locations on the inside of the front bed panel.

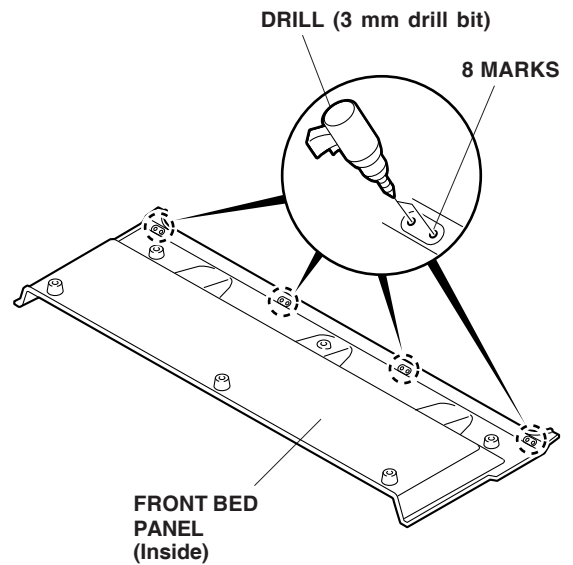

7. While wearing eye protection, use a 15 mm hole saw to enlarge the eight holes you drilled in step 6. Work from the outer surface of the front bed panel. Remove all burrs from the edges of the holes with a file.

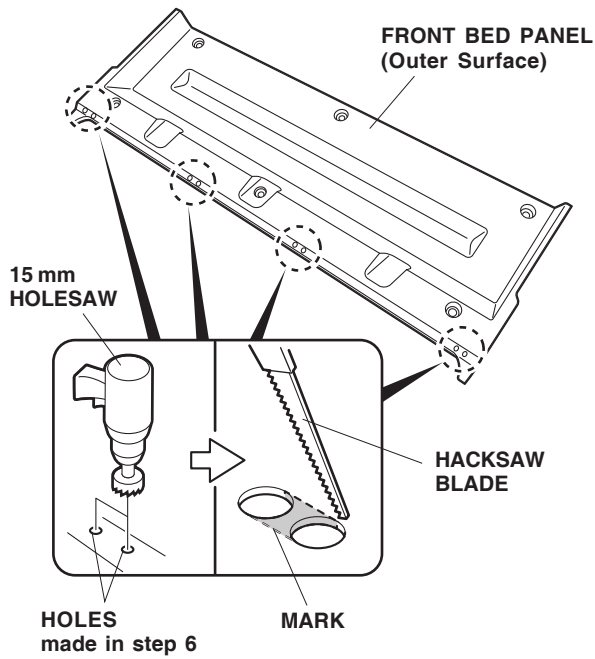

8. Using a hacksaw blade, cut the front bed panel between the marks on both sides.
9. Install the rubber grommets into the holes you just made.

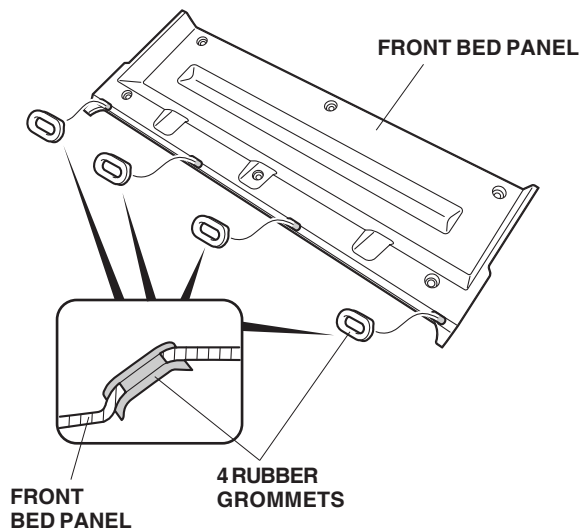

10. Remove the left bed rail trim.
 - Remove the screw cover (four retaining clips).
 - Remove the one self-tapping screw from the rear of the bed rail trim.
 - Slide the bed rail trim back to release the six clips, and remove the bed rail trim.
 - Remove the right bed rail trim the same way.

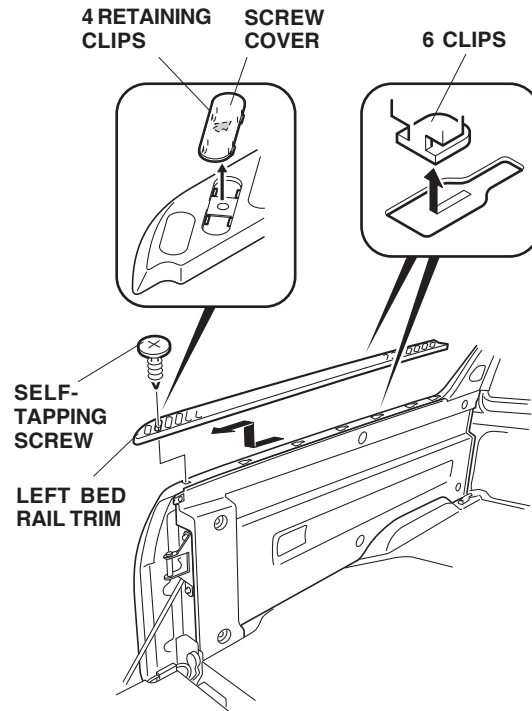

11. Remove the rear roof trim.
 - Remove the rear roof trim bolt covers (three retaining clips for each cover). Remove the two roof trim nuts.

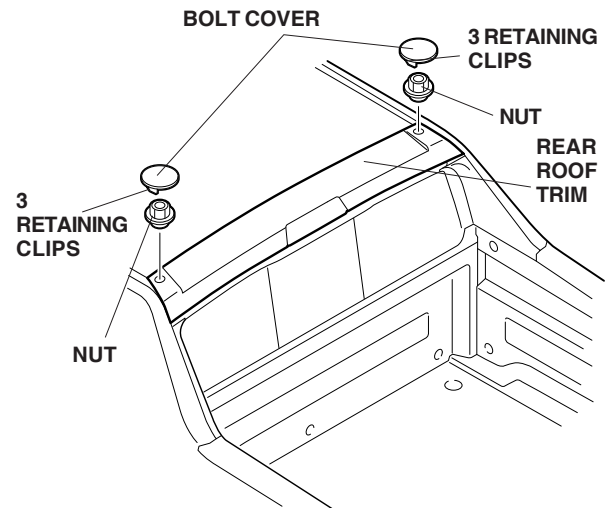

- Using the KTC trim tool, carefully pry up the front of the trim to release the three front clips. Start with the left clip, and work your way to the right clip.
- Gently lift the front of the trim to release the four remaining clips.

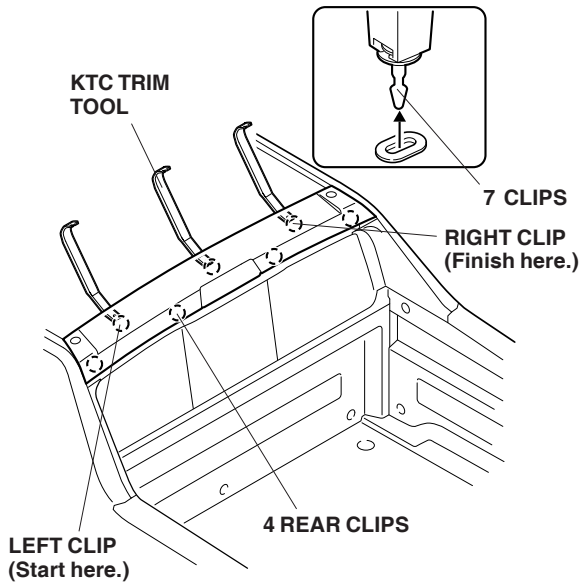

- Gently pull up the rear roof trim to release the two hooks.
- Remove the antenna grommet and the high-mount brake light grommet from the roof panel, disconnect the vehicle connectors, and remove the roof trim.

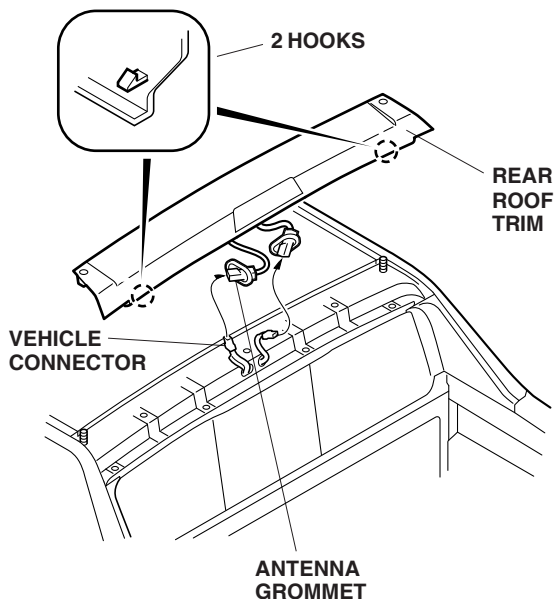

12. Remove the light first (one screw and one connector), then remove the left C-pillar outer trim by sliding it rearward, and disconnect the vehicle connector. Remove the clips from the body, and reinstall the clips to the C-pillar outer trim.

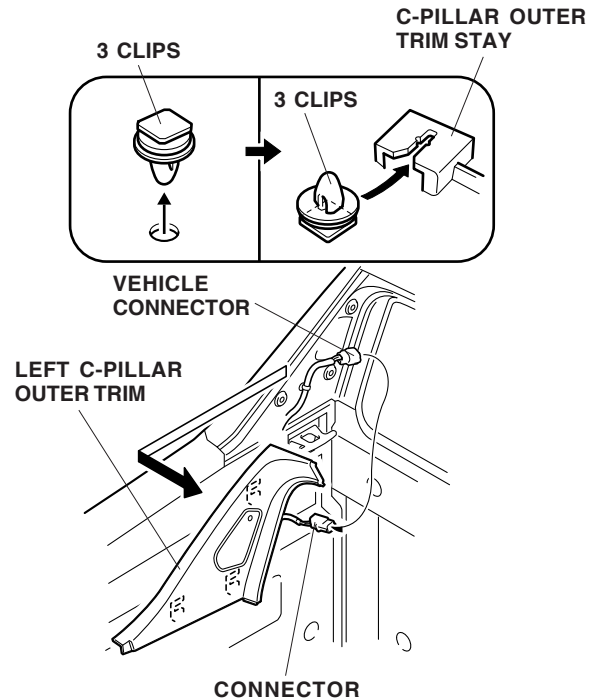

13. Remove the left lower light (one self-tapping screw, pull the left lower light out toward you, and unplug the vehicle connector).

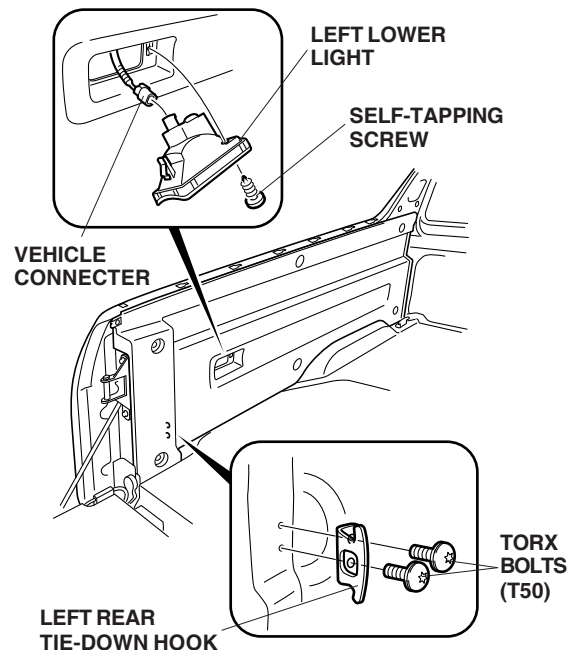

14. Remove the left rear tie-down hook (two torx bolts).

15. Remove the left side bed panel (six torx bolts).

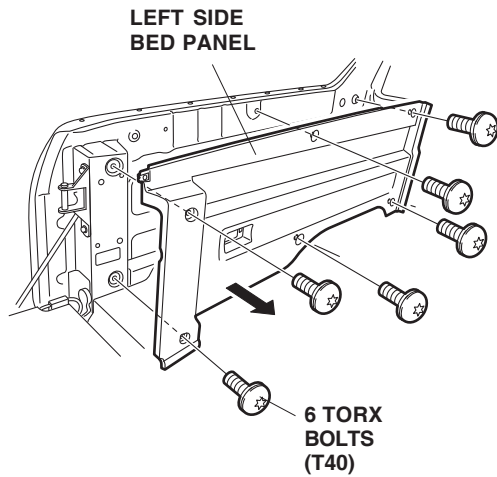

16. Remove the spare tire tie-down clip on the right side panel, then repeat steps 12 thru 15 to remove the right side bed panel.

17. While wearing eye protection, drill a 3 mm hole through each of the eight marked locations.

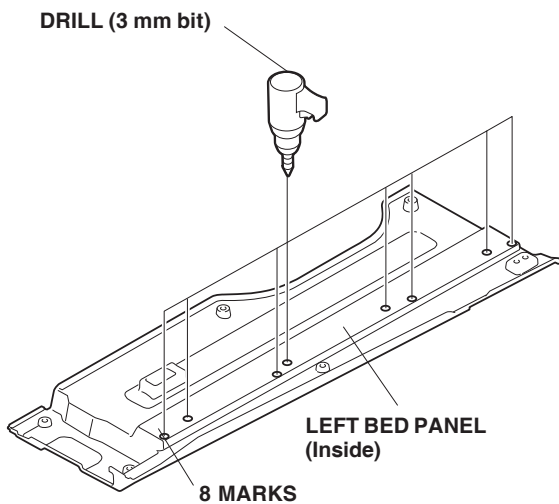

3920161T

18. While wearing eye protection, use a 15 mm hole saw to enlarge the eight holes you drilled in step 17. Work from the front surface of the left bed panel. Remove all burrs from the edges of the holes with a file.

The holes you made in the upper part of the left bed panel are to drain water.

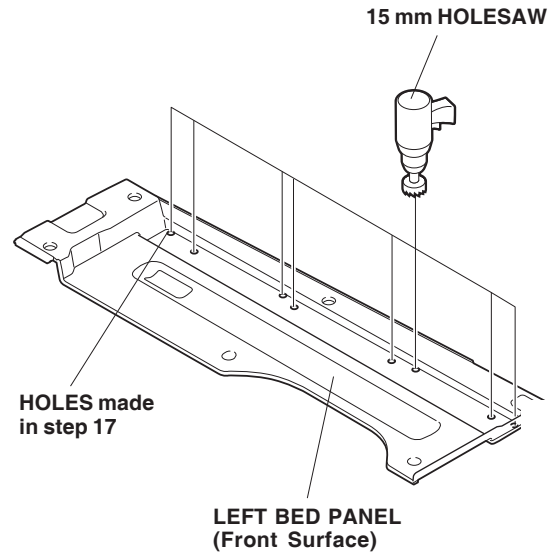

19. Repeat steps 17 and 18 to mark and drill the right bed panel.

20. To prevent damage, wrap electrical tape around the drill bit at a point 30 mm away from the tip. While wearing eye protection, drill a 10 mm hole through each of the three locations on the left side of the lower bed panel. Repeat on the right side.

NOTE: The holes you made are to drain water.

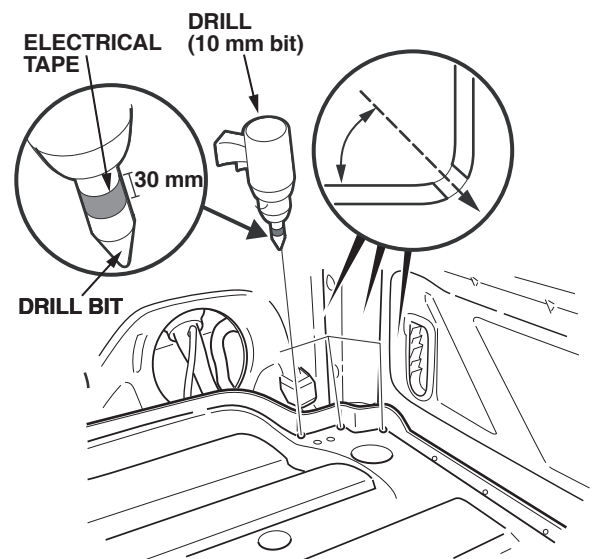

21. Using isopropyl alcohol on a shop towel, clean the left bed panel where the left seal will attach.
22. Remove the adhesive backing from the left seal, and attach it to the left bed panel as shown.

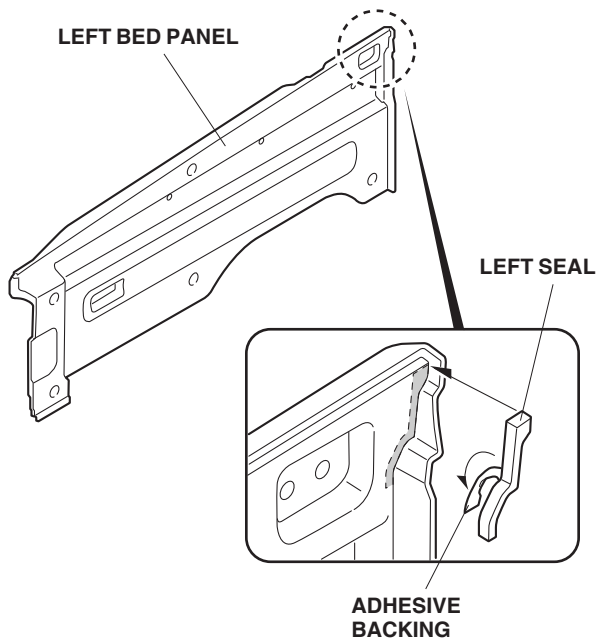

23. Install the right seal to the right side bed panel the same way.
24. Position brackets A, B, C, and D on the left vehicle panel, and install them with two short flange bolts for each bracket.

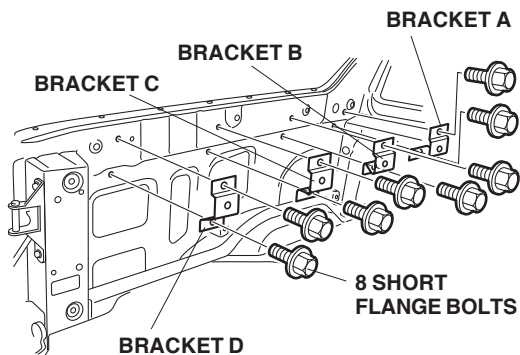

25. Position brackets A, C, and D on the right vehicle panel, and install them with two short flange bolts for each bracket.

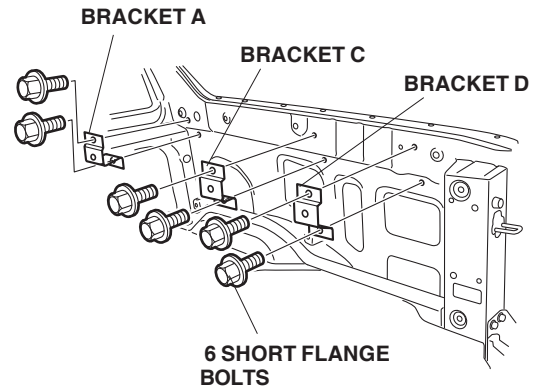

26. Reinstall the left and right bed panels.
27. Reinstall the right and left C-pillar outer trims.
28. Remove and discard the grommets from the roof panel, and install the ellipse grommets and one circle grommet to the roof panel.

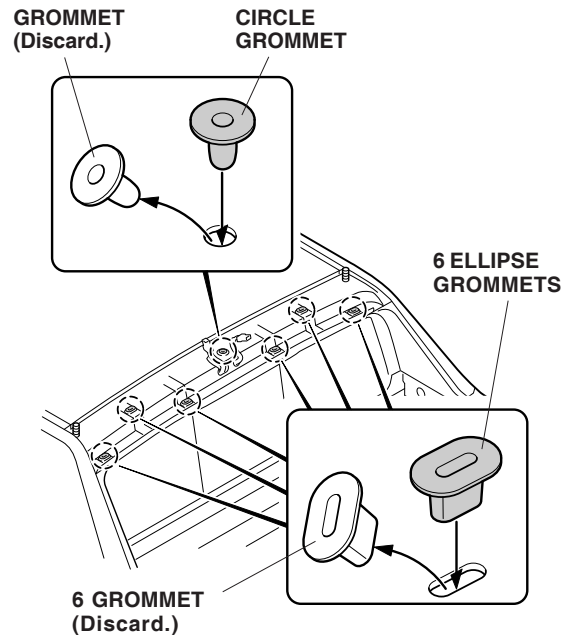

29. On the back of the rear roof trim, remove and discard the clips from the rear roof trim, and install the seven clips.

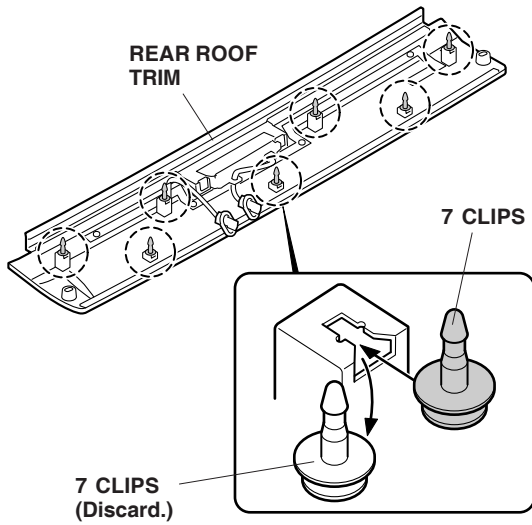

30. Reinstall the rear roof trim.
 31. Install the left and right rail caps to the front bed panel rail.

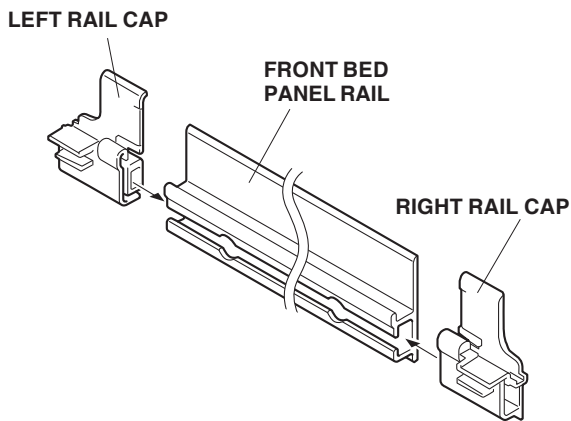

32. Using isopropyl alcohol on a shop towel, clean the left rail where the water stoppers will attach.
 33. Get the water stoppers and clips, remove the adhesive backings from the three water stoppers, and attach them to the left rail. Attach the three clips into the holes in the water stoppers.

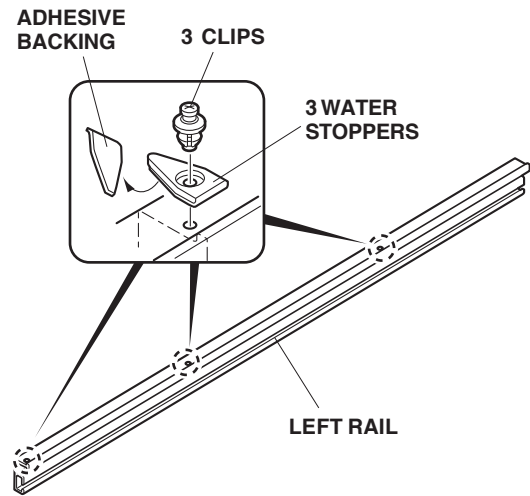

34. Install the water stoppers to the right rail the same way.
 35. Place the front bed panel in position, and loosely install the three bottom bolts.

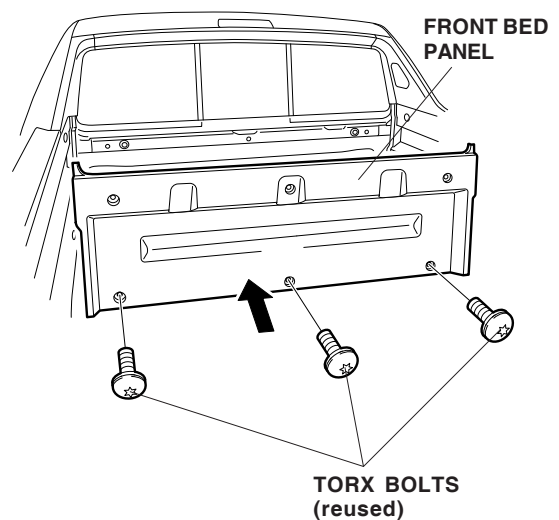

36. Check that the seal you attached in step 21 is not twisted or collapsed. If it is, raise it by inserting a scale or small screw driver.

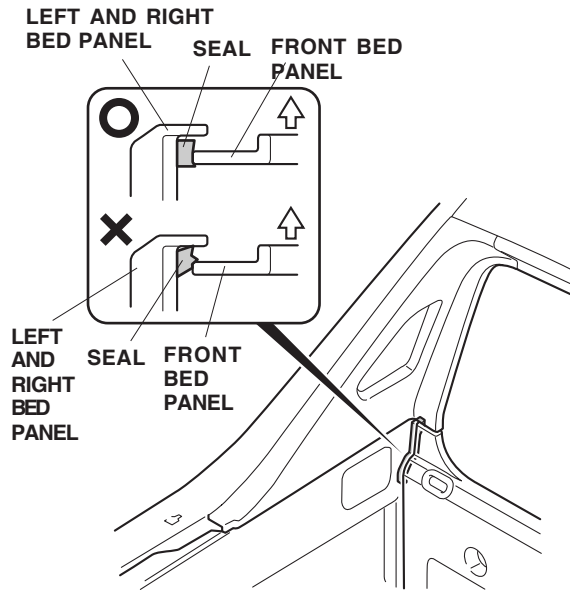

37. Position three collars, (one washer with the center collar) and the front bed panel rail against the front bed panel, and install three long flange bolts. Tighten the flange bolts and the torx bolts installed in step 35.

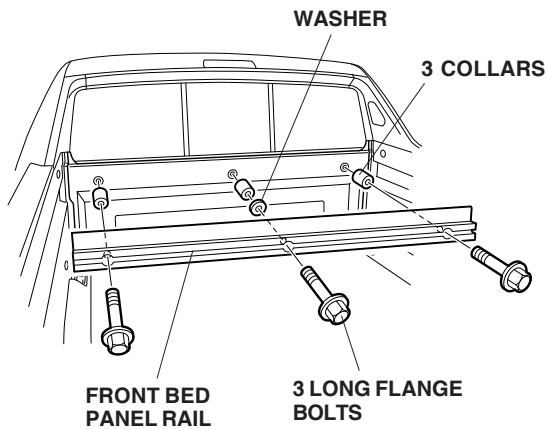

38. Slide or push (by hitting with a rubber hammer) the left and right rail caps until they contact the bed panel.

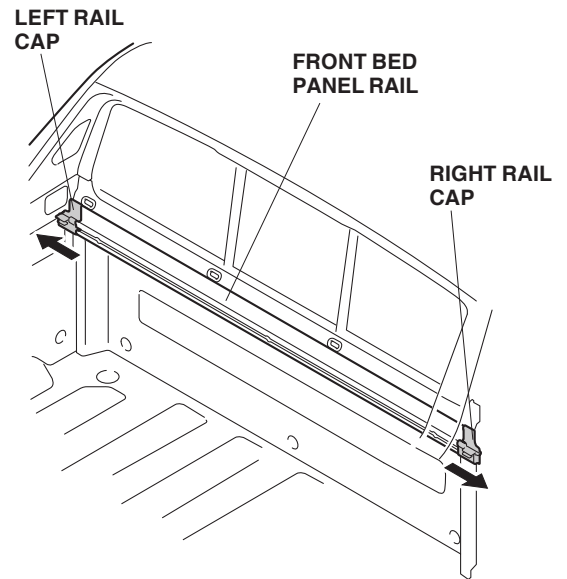

39. Position the left rail to the left bed panel, and install four bumper bolts. Install the right rail the same way.

NOTE: Make sure the rail fits into the rail cap.

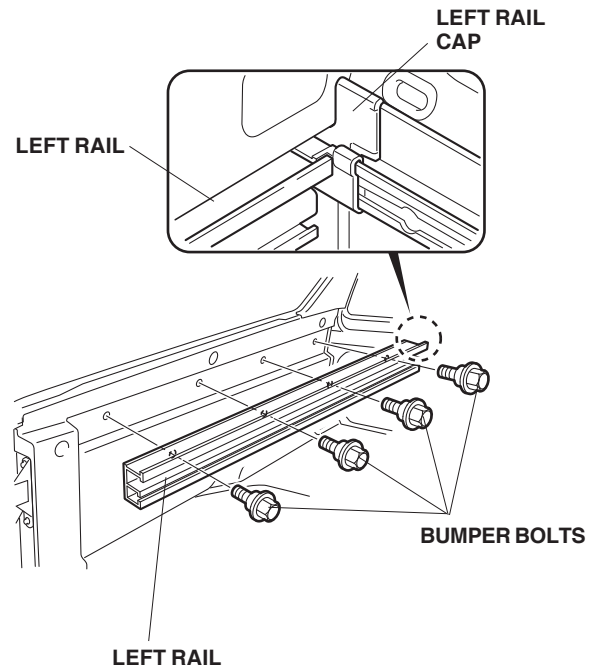

40. Insert two plate nuts into the slots in the left and right rails.

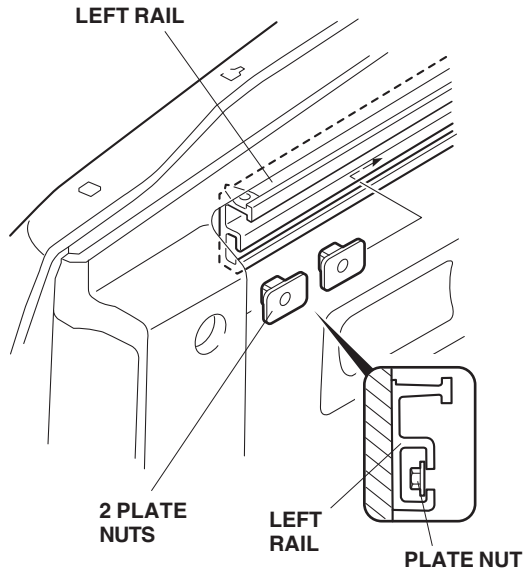

41. Remove the tailgate trim:

- Remove the four screws and release the one end clip on each side.
- Using a rubber mallet, sharply strike the left edge of the tailgate trim to slide the trim to the right and release the 16 clips from the trim.
- Remove the 16 clips from the tailgate and reinstall the 16 clips to the tailgate trim in the direction shown.

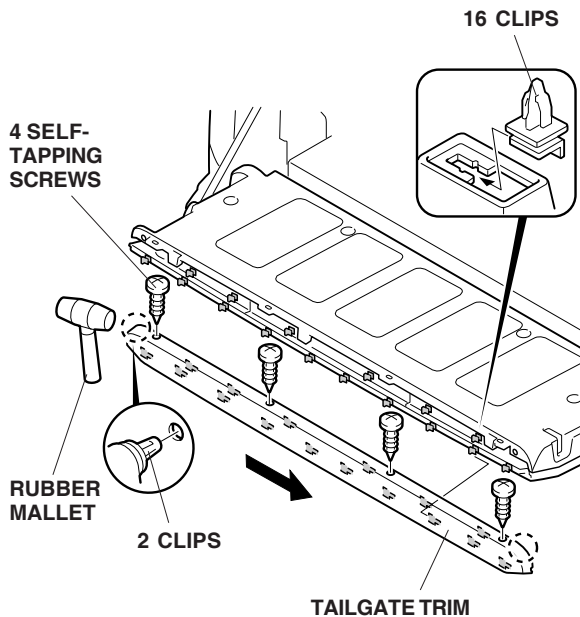

42. Using a felt-tip pen, mark the tailgate panel at the center of the torx bolt located at the right end of the tailgate panel.

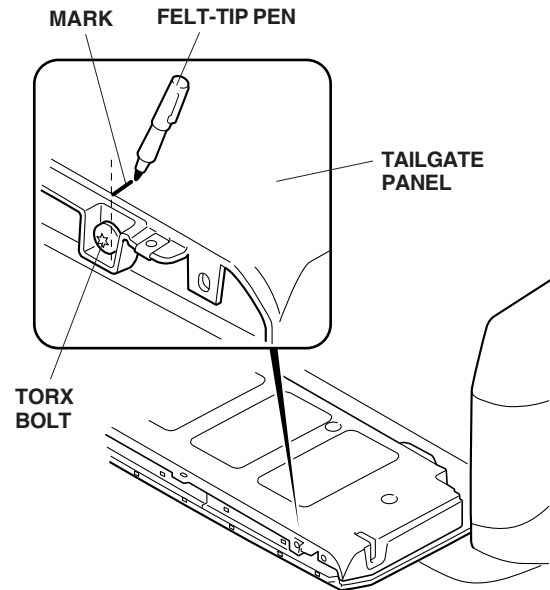

43. Install the tailgate trim on the tailgate panel. Using a felt-tip pen, mark the tailgate trim where it aligns with the mark you just made on the tailgate panel.

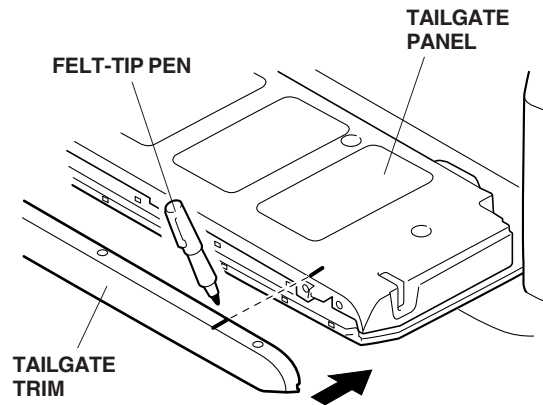

44. Remove the tailgate trim. Measure the tailgate trim from the marked point to the dimensions shown, and cut out the tailgate trim.

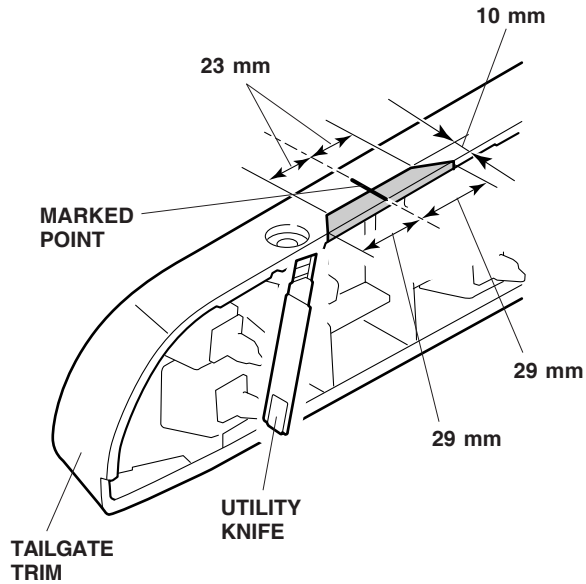

45. Remove the torx bolt from the right end of the tailgate panel. Install the lock bracket on the tailgate panel with the TORX bolt you just removed.

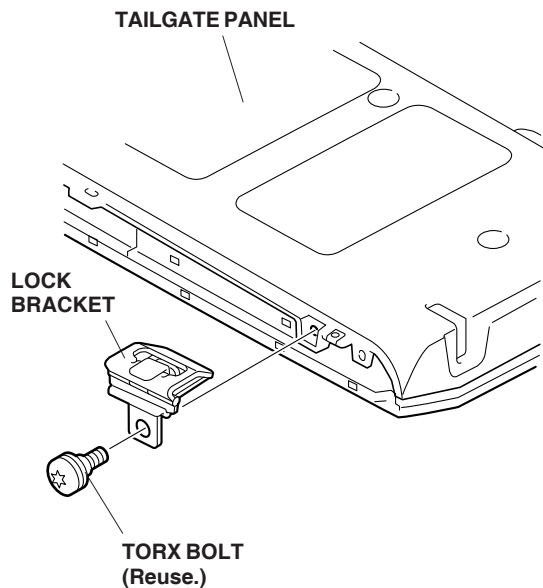

46. Reinstall the tailgate trim.
47. Reinstall the tie down hooks.

48. Fold the tonneau cover, and attach it to the bed rail. Check that the projection of the bed rail sets in the concave section of the tonneau cover securely. Note that the tonneau cover is heavy. Work with an assistant when you install the tonneau cover.

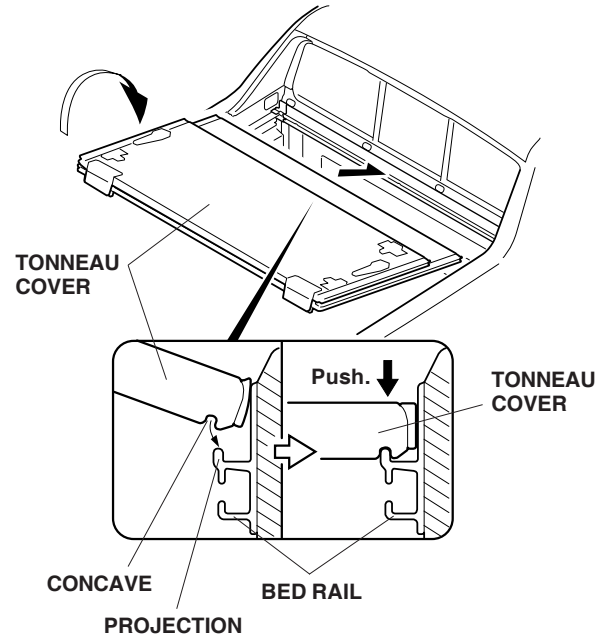

49. Install the four brackets to the four plate nuts with the 6 x 20 mm washer-bolts. Do not tighten them yet.

Install the left brackets in front of the brackets on the underside of the tonneau cover. Install the right brackets behind the brackets on the underside of the tonneau cover.

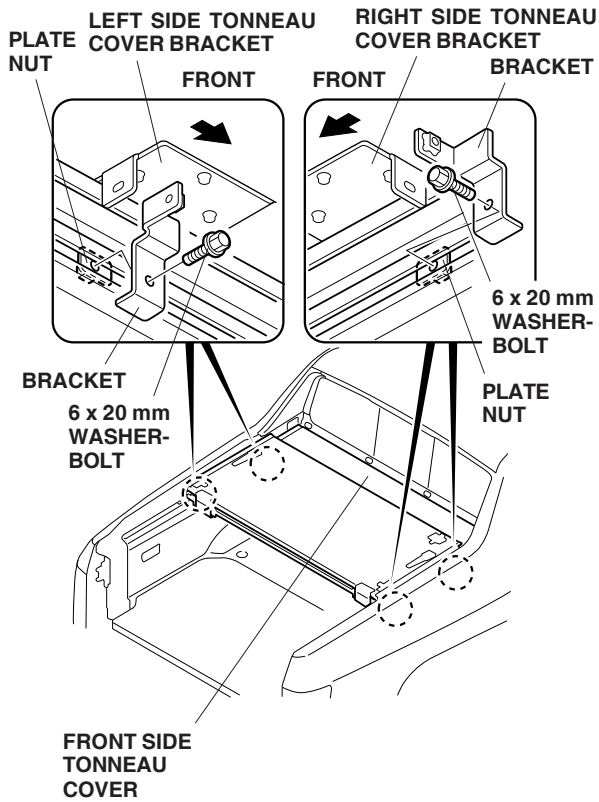

50. Push the tonneau cover forward. Slide the brackets and align the holes in the bracket with the holes in the tonneau cover brackets, then install the 6 x 14 mm washer-bolts.

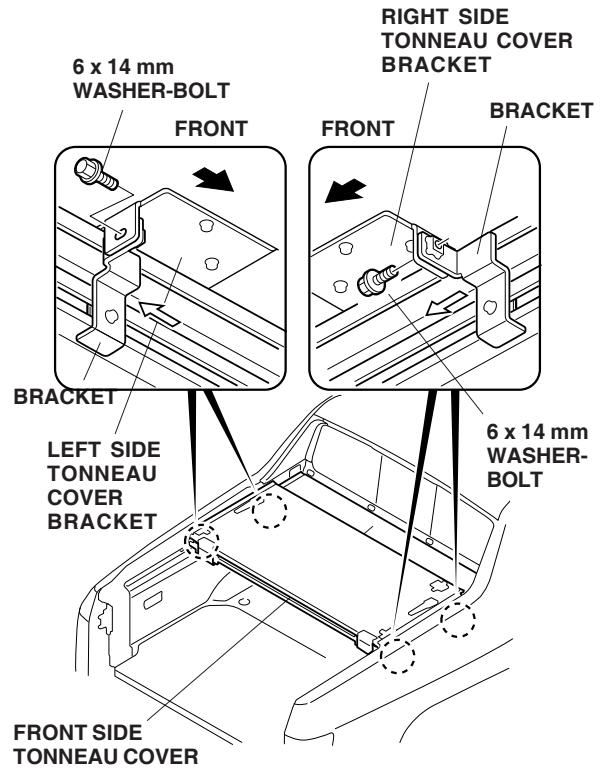

51. Unfold the tonneau cover. Open and close the tailgate 3 to 4 times until the tonneau cover fits properly. Then tighten the 6 x 20 mm washer-bolts.

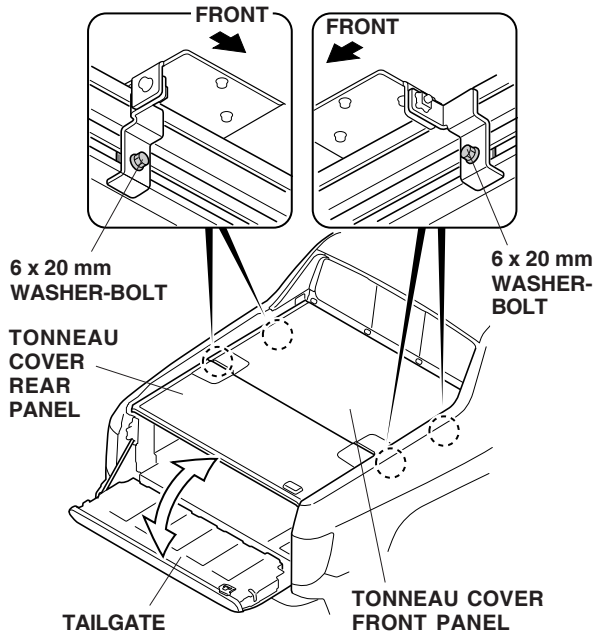

52. Attach cushion tape to both hinges. Attach the tape to the front half of the hinge so that it cushions the rear half of the hinge as shown.

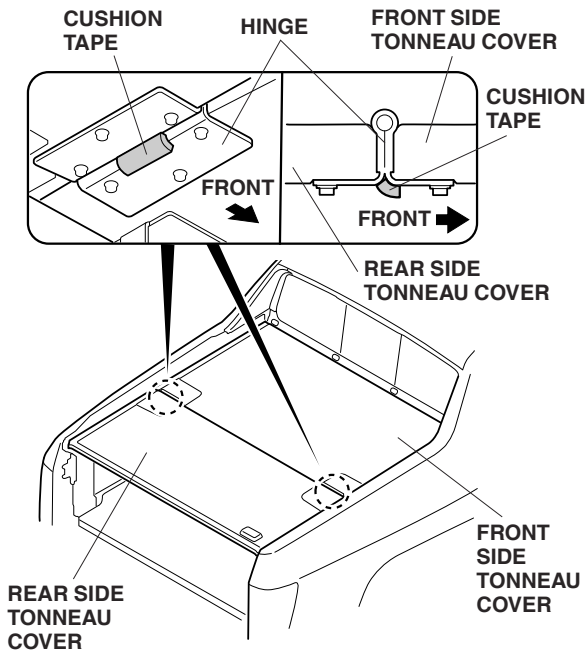

53. Lock the rear of the tonneau cover by turning the two knobs 90 degrees.

2 KNOBS
(Turn 90 degrees to lock.)

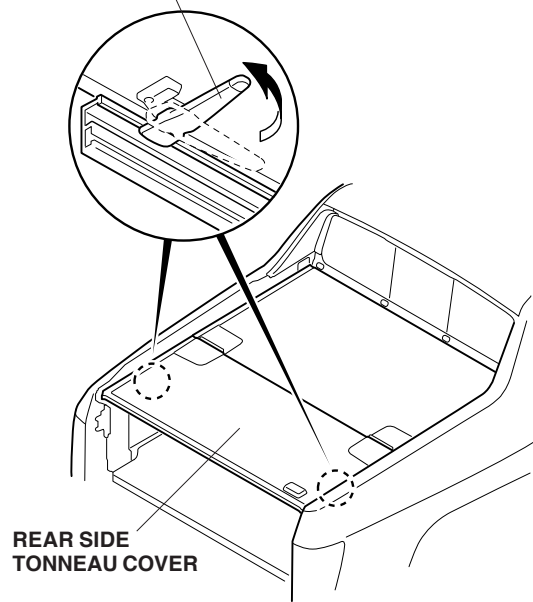

54. Turn the two knobs to unlock the tonneau cover.
55. Reinstall all removed parts.

NOTE: To reinstall the bed rail trim:

- With one hand on each end of the bed rail trim, hook the seven clips under the bed liner lip.

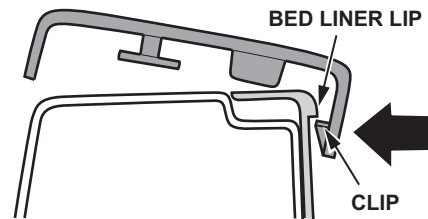

- Roll the trim toward the outside of the bed rail, so the trim now lies flat on top of it and all six lock tabs engage the slots in the bed rail.

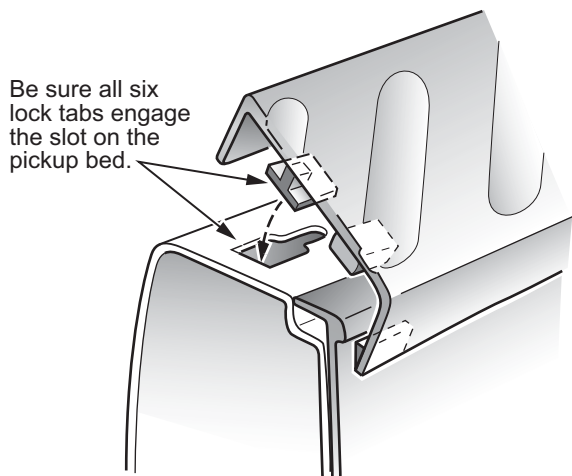

- With one hand on each end of the trim, push down and slide it toward the cab until you feel it stop. This locks all the tabs in place.
 - Starting at the front end, press up on the edge of the trim with your thumb to make sure it's secure. Then, working your way down the trim, repeat this to ensure the other lock tabs and the clips are secure.
 - Reinstall the mounting screw and the trim cap.
56. Reconnect the negative cable to the battery.
 57. Reset the clock, and reset the radio station presets.
NOTE: Whenever the battery is disconnected, the driver's window AUTO function is disabled.
 58. Start the engine. Push down on the driver's window switch until the window is fully open.
 59. Check that the cargo lights are working.
 60. Pull up on the driver's window switch to close the window completely, then hold the switch for 2 seconds or more.
 61. Lower and raise the window to check the operation of the driver's window AUTO function.
 62. Give the keys to your customer.