

PARTS LIST

Back-up sensor harness

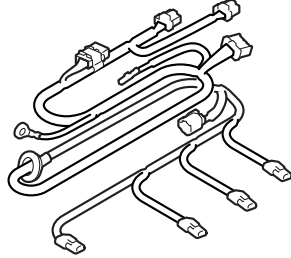

Control unit

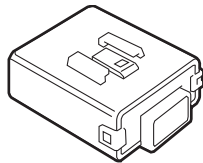

Buzzer

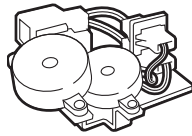

Fuse label

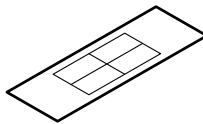

5 EPT sealers

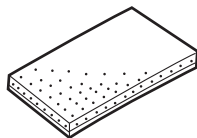
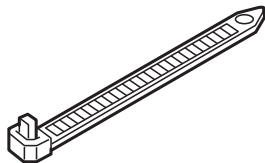
40 Wire ties
(7 Not used)

9 Small wire ties

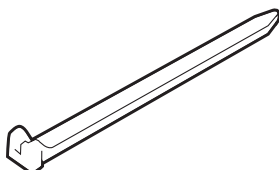
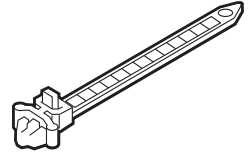
3 Wire ties with small clip
(2 Not used)

2 Wire ties with large clip

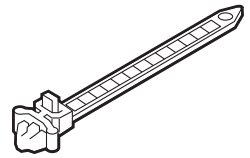

Flange bolt



Buzzer bracket

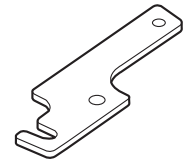

Control unit bracket

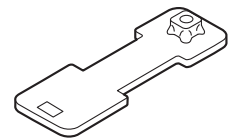

Switch

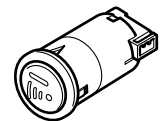

Ground bolt

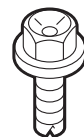

2 Corner sensors

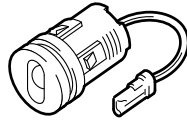

2 Center sensors

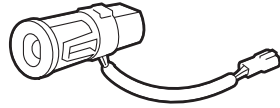

2 Retainer clips



3 Cushion tapes
(Some may not be used)

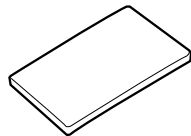

User's information manual

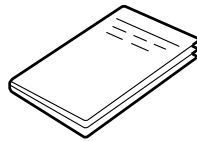

Tailgate switch

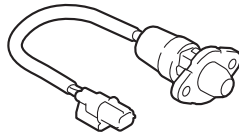

Tailgate switch bracket

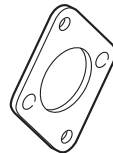

Template

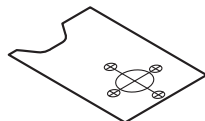

4 Washer-screws, 4 x 14 mm



2 Well nuts



Corrugated tube

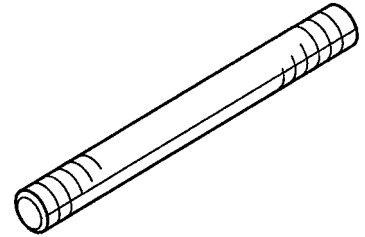

Flange nut



Washer-screw, 6 x 12 mm



6 Oval grommets



Round grommet



7 Clips



TOOLS AND SUPPLIES REQUIRED

Phillips screwdriver
Small flat-tip screwdriver
10 mm Combination wrench
10 mm and 14 mm Sockets
Pushpin
Ratchet
3 mm and 8 mm Drill bits
Eye protection (face shield, safety goggles, etc.)
File
Diagonal cutters
Tape measure
Isopropyl alcohol
Shop towel
20 mm and 26 mm Hole saws
Drill
Utility Knife
Scissors
T-30, T-40, and T-50 Torx drivers
Insulation tape
Center punch
4 mm Hex wrench
Torque wrench
Touch-up paint
Blanket
Adhesive tape
Plastic trim tool T/N SILTRIMTL10

Illustration of the Back-Up Sensors Installed on the Vehicle

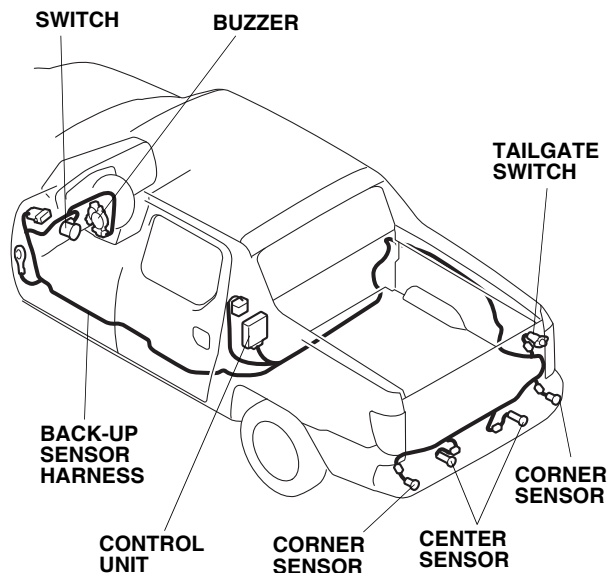

Customer Information: The information in this installation instruction is intended for use only by skilled technicians who have the proper tools, equipment, and training to correctly and safely add equipment to your vehicle. These procedures should not be attempted by “do-it-yourselfers.”

1. Make sure you have the anti-theft code for the radio, then write down the radio station presets.
2. Disconnect the negative cable from the battery.

Removing the Vehicle Parts

3. Remove the left dashboard side cover (seven clips).

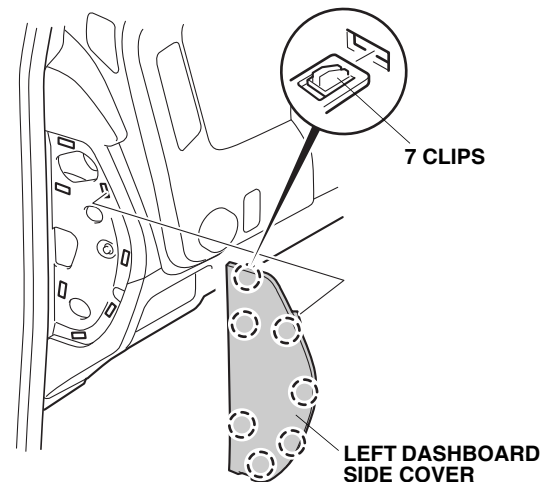

INSTALLATION

- Remove the driver's dashboard lower cover (one self-tapping screw, nine clips, unplug the vehicle connectors, and the vehicle tube).

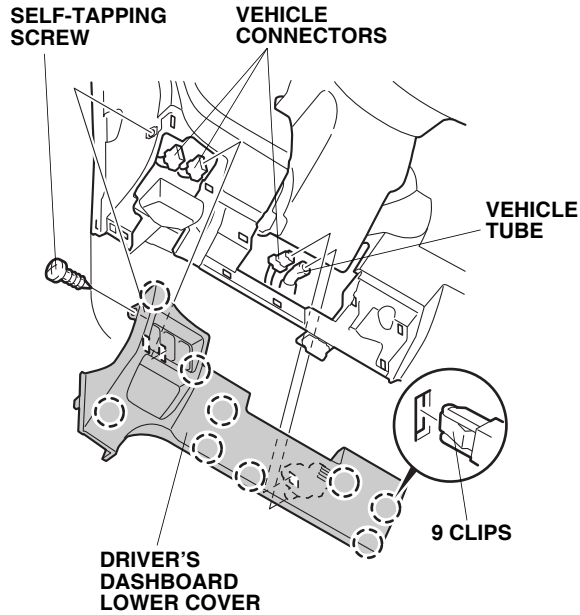

- Remove the driver's console side trim (three clips and one retaining tab).

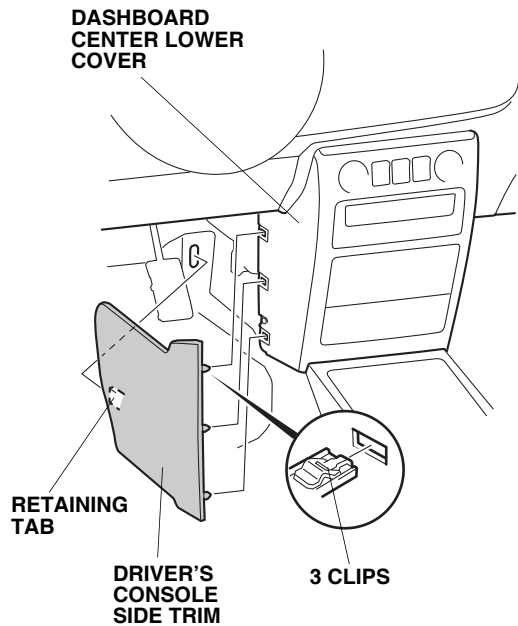

- Remove the passenger's console side trim (two clips and retaining tab).

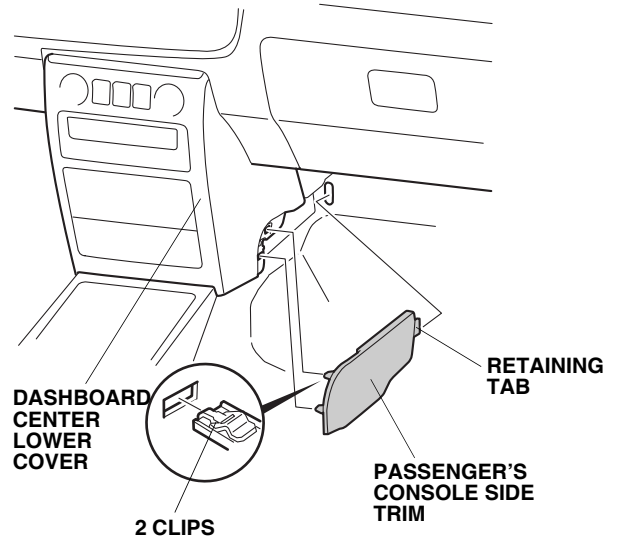

- Open the center pocket, and remove the center pocket out towards you.

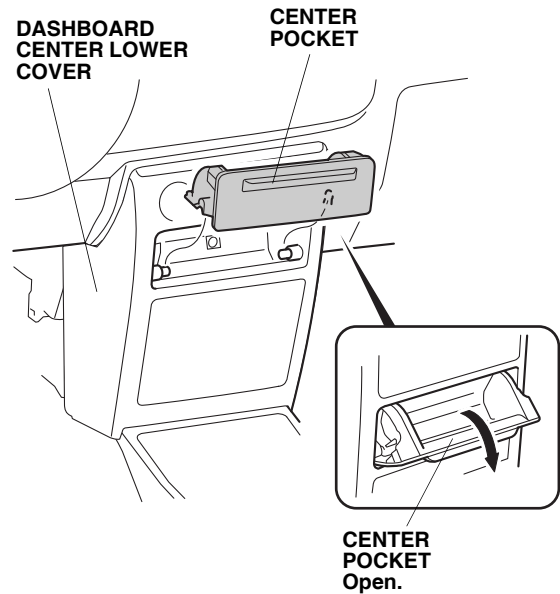

- Remove the dashboard center lower cover (three self-tapping screws, five clips, six retaining tabs, and unplug the vehicle connectors).

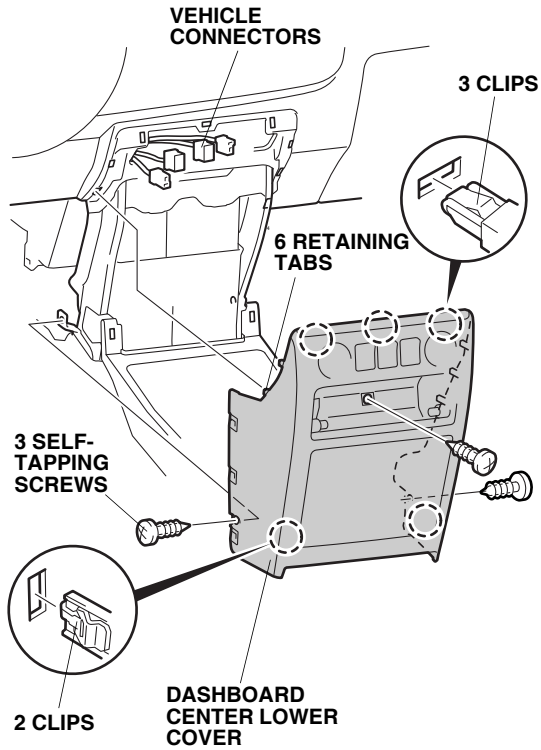

- Remove the fuel fill door release handle. Remove the left front door sill trim (three clips and three retaining tabs).

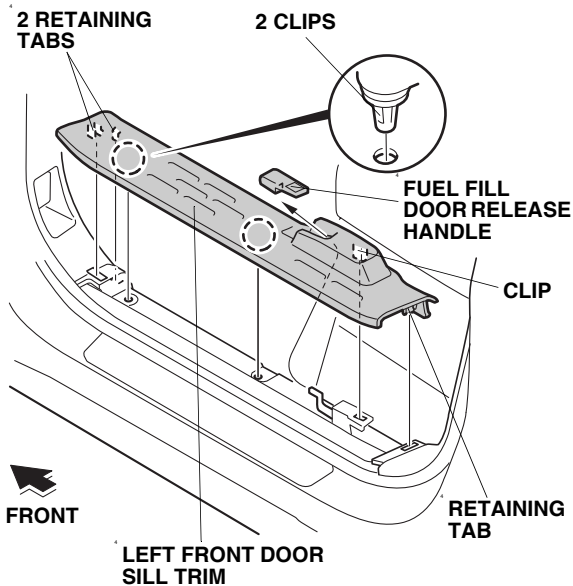

- Pull back the weatherstrip from the left kick panel. Remove the left kick panel (one screw clip and one clip).

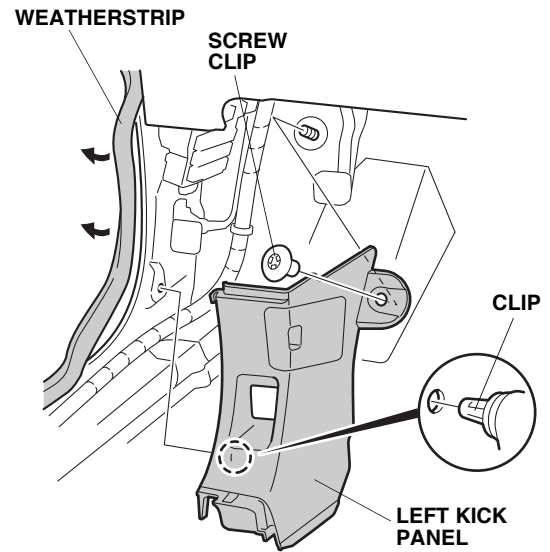

- Remove the left rear door sill trim (three clips and four retaining tabs).

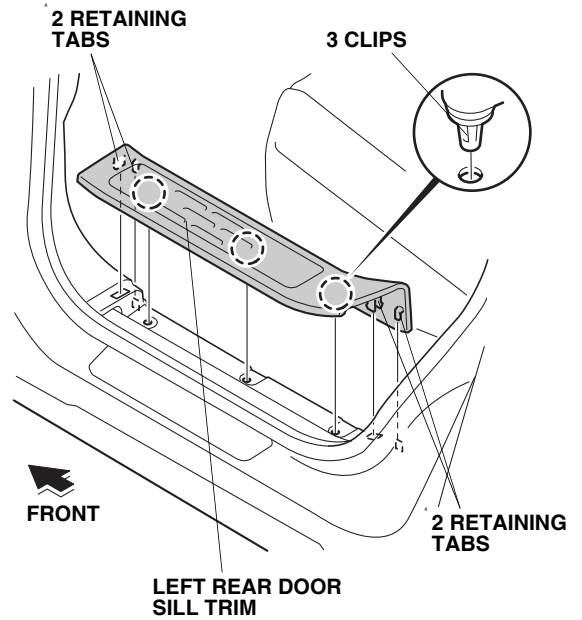

If the vehicle is equipped with a left seat belt lower anchor bolt, continue with step 12; if not, go to step 14.

12. Pull up the left seat belt lower anchor bolt cover, and remove the left seat belt lower anchor bolt.

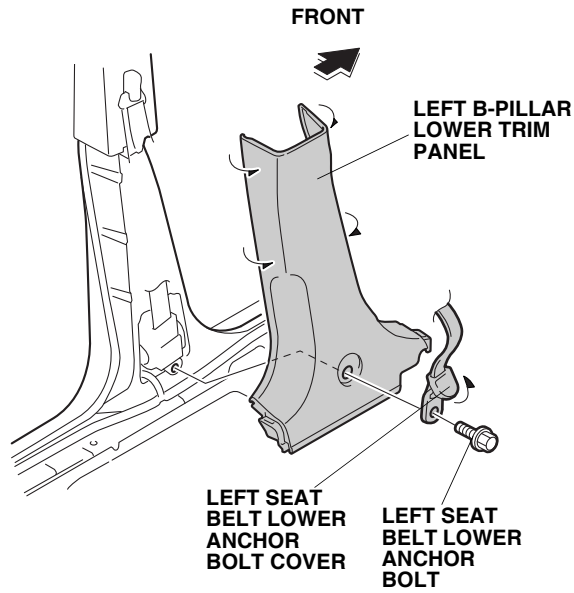

13. Remove the left B-pillar lower trim panel by pulling out toward you as shown. Go to step 15.
14. Remove the left B-pillar lower trim panel by pulling out toward you as shown.

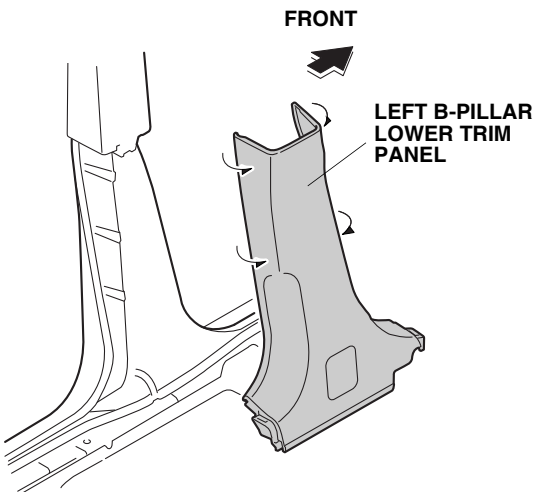

15. Lift the rear seat cushion.

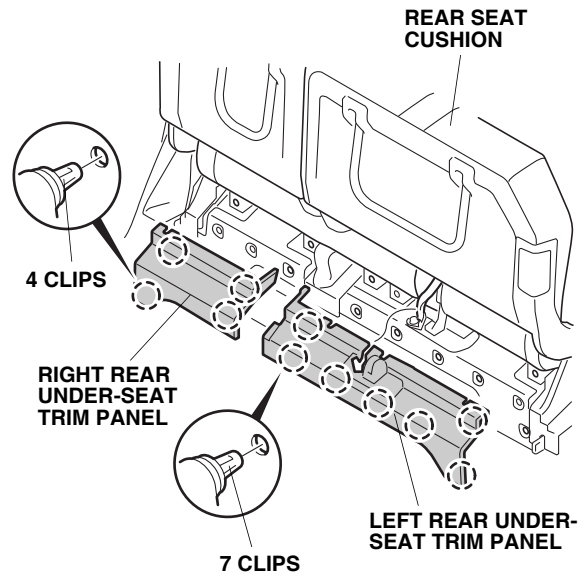

16. Remove the left rear under-seat trim panel (seven clips).
17. Remove the right rear under-seat trim panel (four clips).

18. Remove the left and right rear seat mount covers (four clips).

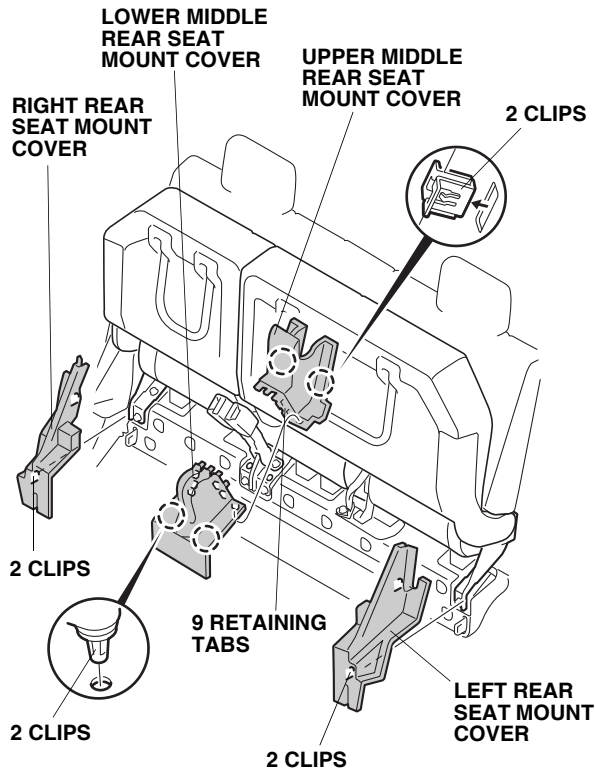

19. Remove the upper middle rear seat mount cover (hold the seat belt buckles down, and pull up to release the two clips and nine retaining tabs).
20. Remove the lower middle rear seat mount cover (two clips).

21. Remove the nine anchor bolts.

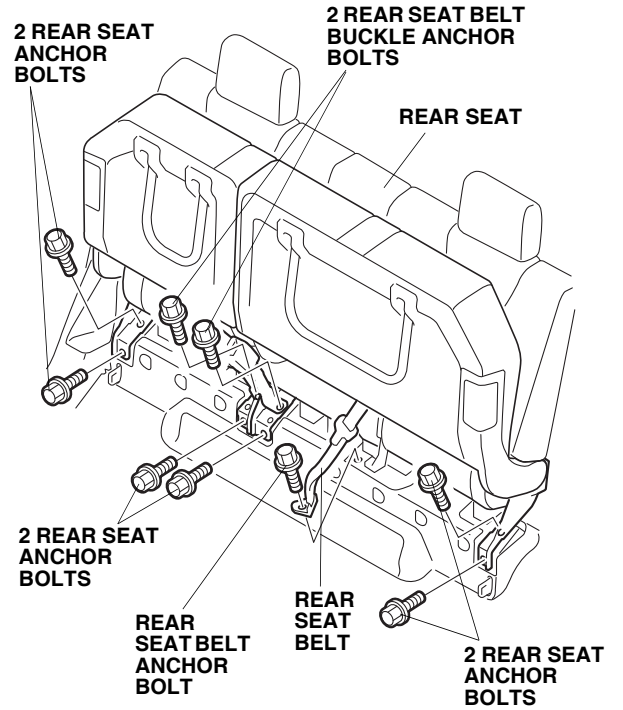

22. Remove two caps from the rear trim panel cover (eight retaining tabs).

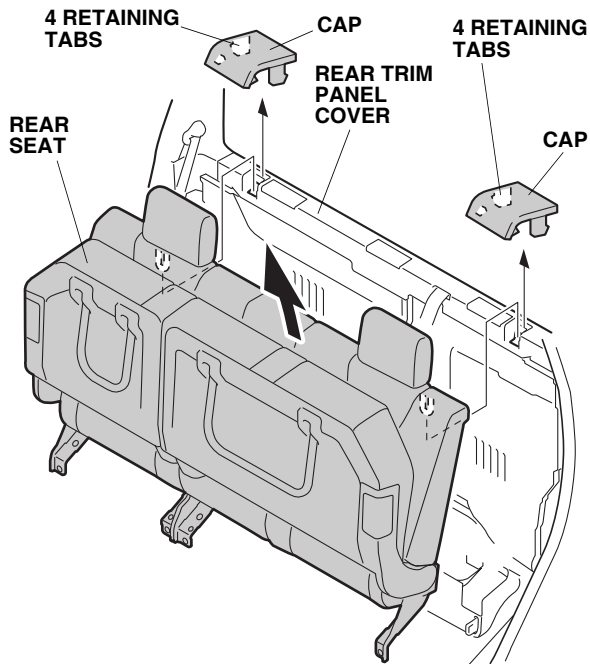

23. Remove the rear seat. Have an assistant help you.

24. Remove the rear trim panel cover (two clips, two retaining tabs, and six clips).

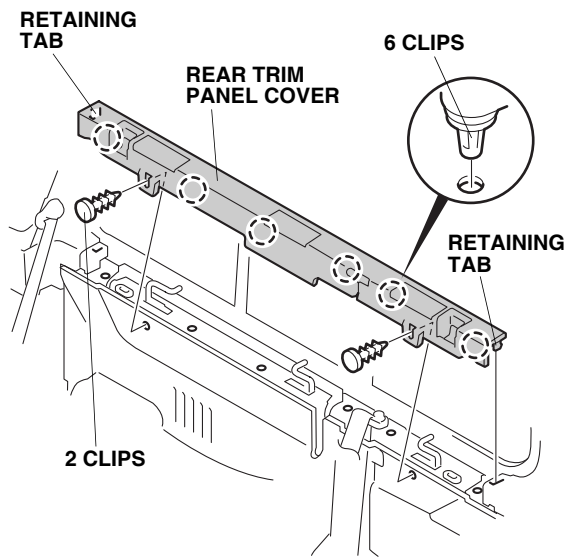

25. Remove the right rear seat belt upper anchor bolt cover (three retaining tabs), and remove the right rear seat belt upper anchor bolt.

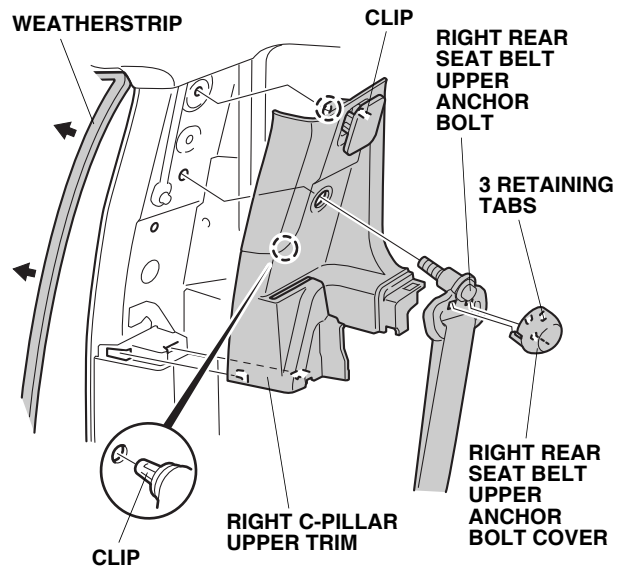

26. Pull back the weatherstrip from the right C-pillar upper trim. Remove the right C-pillar upper trim.
- With side airbag; release the clip partway, and remove the right C-pillar trim by releasing the one clip.
 - Without side airbag; remove the right C-pillar trim by releasing the two clips.

27. Remove the right rear door sill trim (three clips and four retaining tabs).

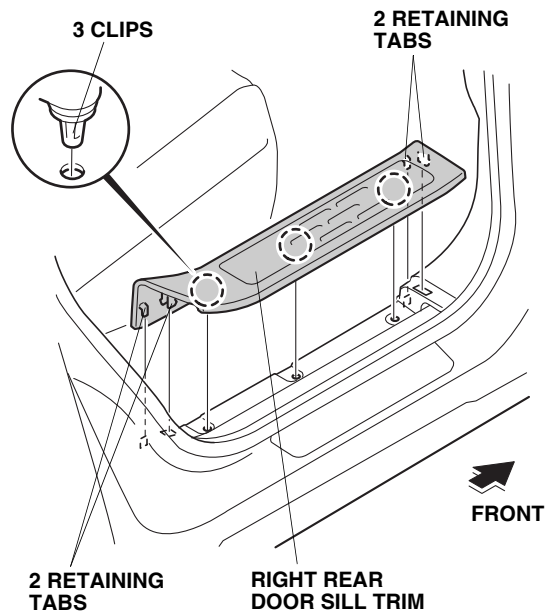

28. Pull up the right rear seat belt lower anchor bolt cover, and remove the right rear seat belt lower anchor bolt.

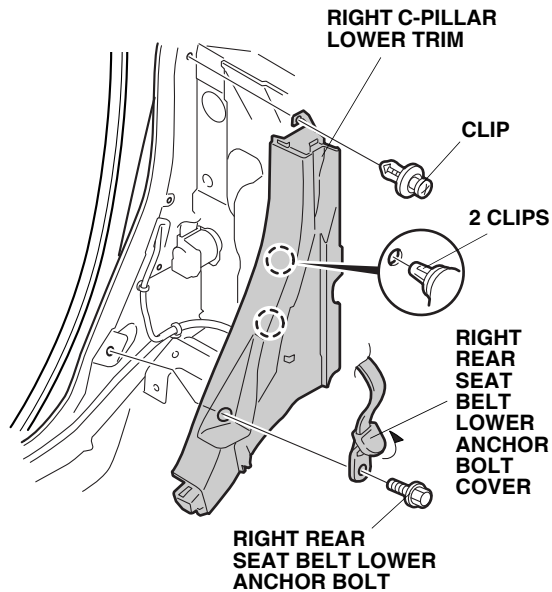

29. Remove the upper clip, then remove the right C-pillar lower trim by releasing the two clips.
 30. Repeat steps 25 through 29 to remove the left C-pillar upper and lower trim.

If the vehicle is equipped with a subwoofer, continue with step 31; if not, go to step 32.

31. Unplug the vehicle connector. Remove the four bolts, and remove the subwoofer by pulling upward the two hooks.

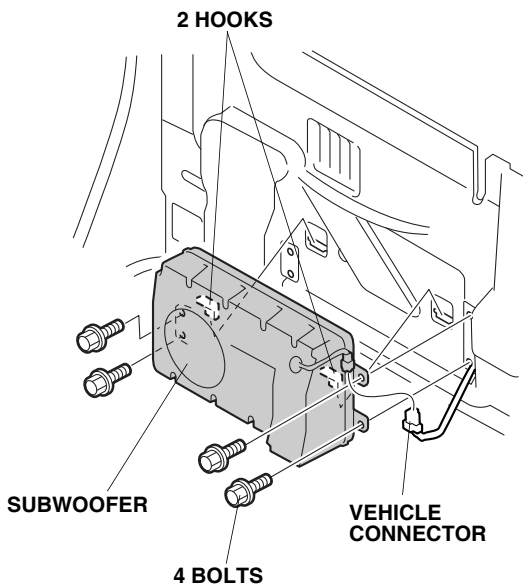

32. Remove the rear trim panel (three clips).

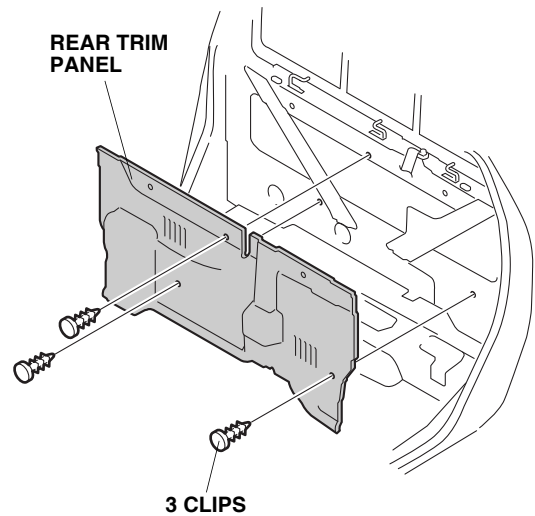

33. Remove two rear roof trim bolt covers (six retaining tabs). Remove two roof trim nuts.

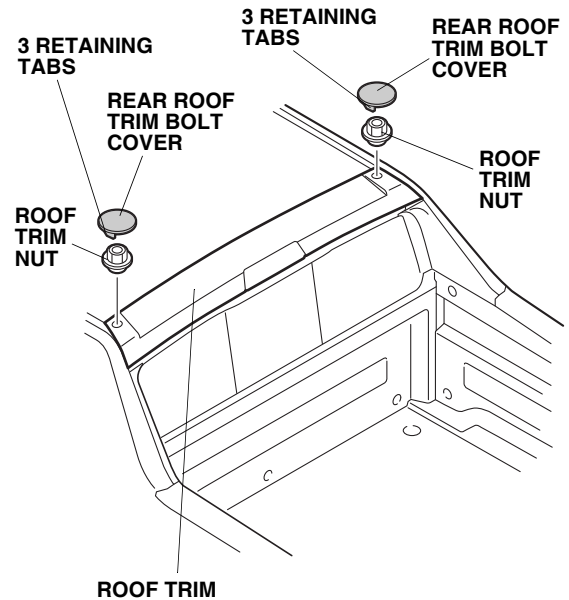

34. Using a plastic trim tool, carefully pry up the front of the roof trim to release the three front clips. Start with the left clip, and work your way to the right clip.

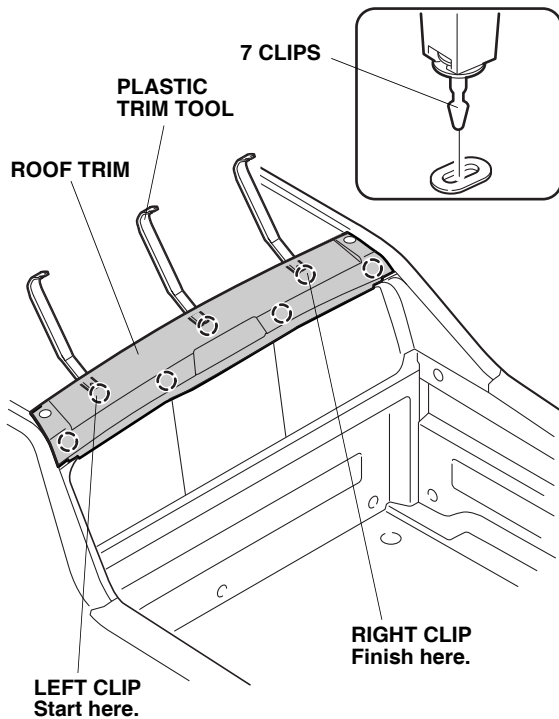

35. Gently lift the front of the roof trim to release four remaining clips.

36. Gently pull up the roof trim by releasing two hooks.

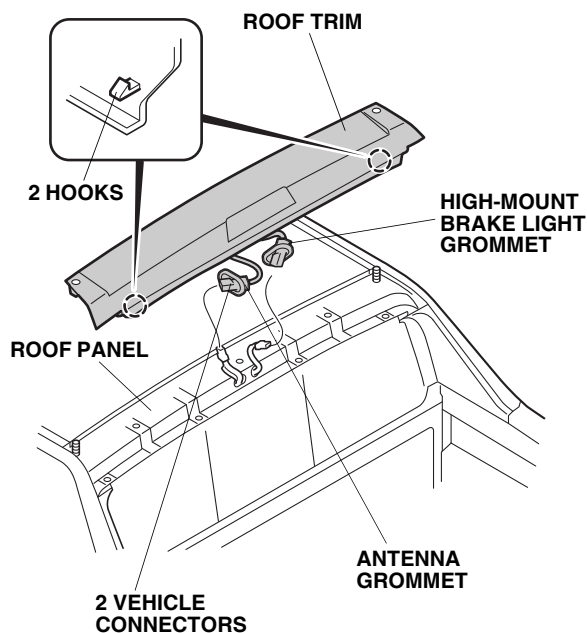

37. Remove the antenna grommet and high-mount brake light grommet from the roof panel, unplug the vehicle connectors, and remove the roof trim.

38. Remove seven vehicle grommets from the roof panel, and install six new oval grommets and one new round grommet into the roof panel as shown.

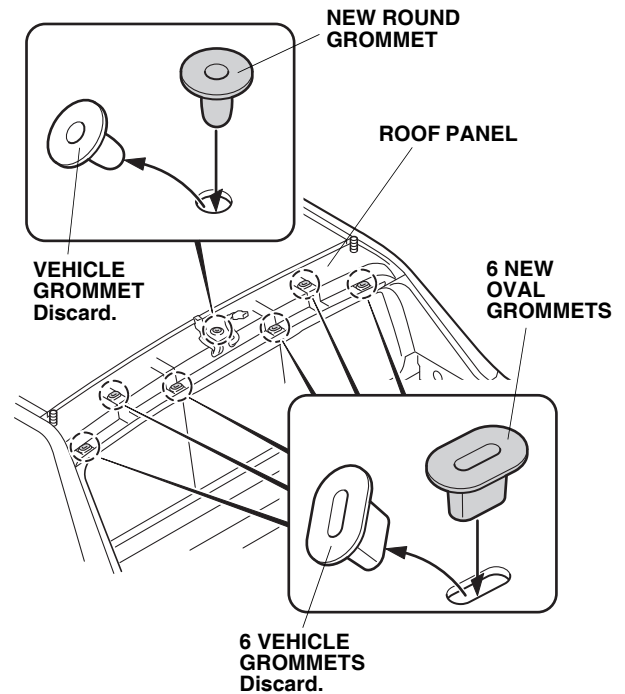

39. On the roof trim backside, remove seven vehicle clips from the roof trim, and install seven new clips to the roof trim.

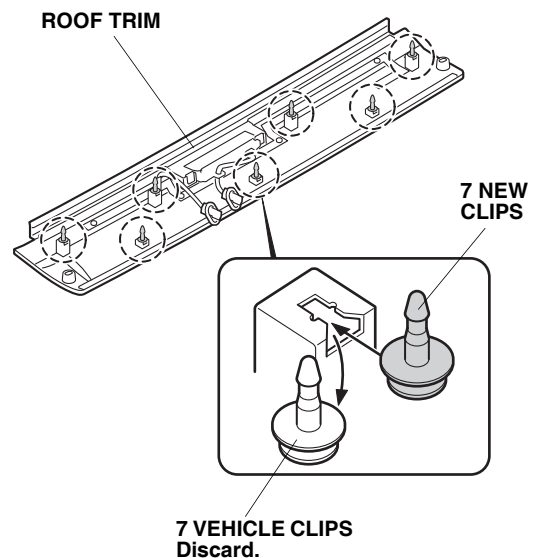

40. Remove the screw cover from the rear of the right bed rail trim (four retaining tabs).

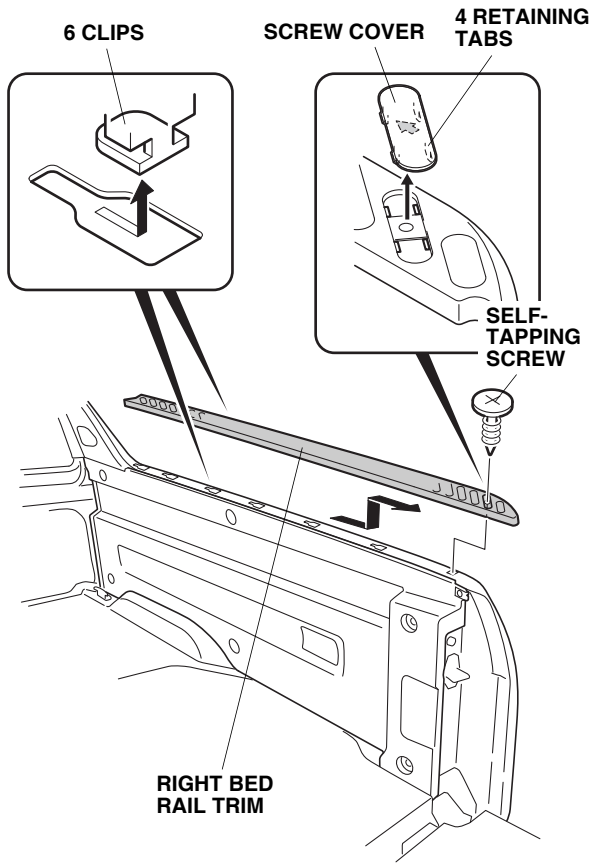

41. Remove one self-tapping screw from the rear of the right bed rail trim.
 42. Pull the right bed rail trim back to release the six clips, and remove the right bed rail trim.

43. Remove the right C-pillar outer trim (slide rearward, and unplug the vehicle connector).

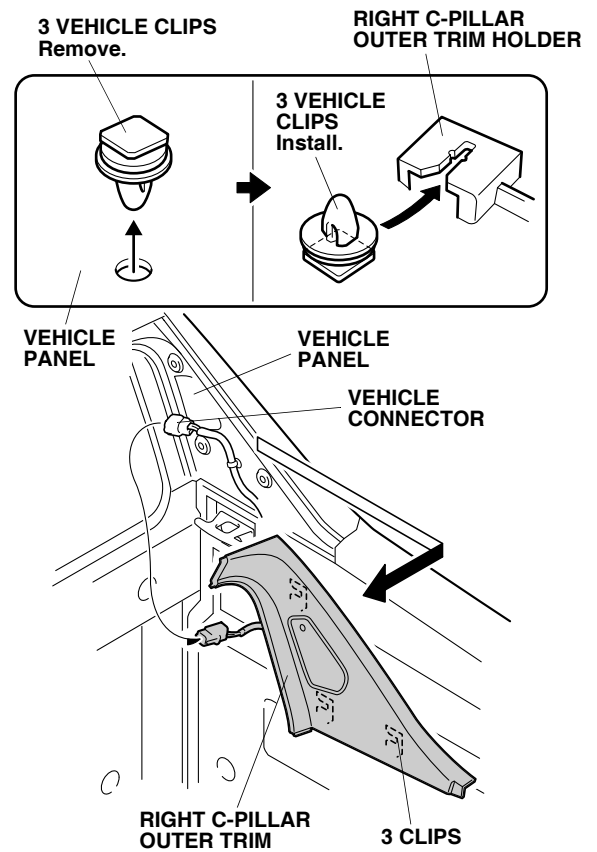

44. Remove the three vehicle clips from the vehicle panel, and install them to the right C-pillar outer trim holder.
 45. Remove the right front upper tie-down hook (two T-50 torx bolts). Repeat the same procedure for the left side.

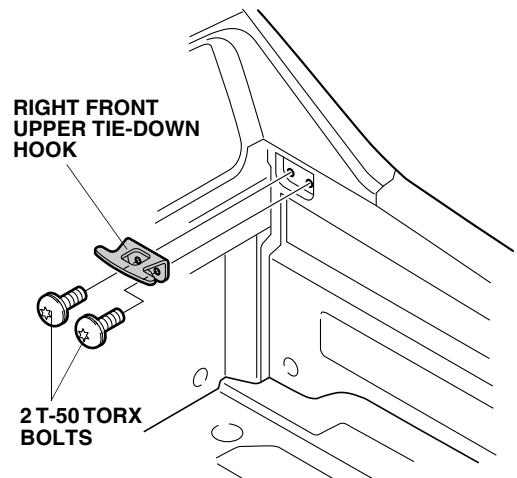

46. Remove the front board panel (six T-40 torx bolts).

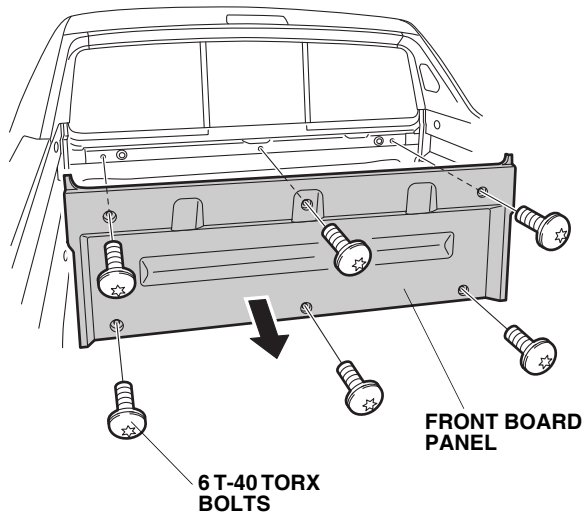

47. Remove two right rear tie-down hooks (four T-50 torx bolts).

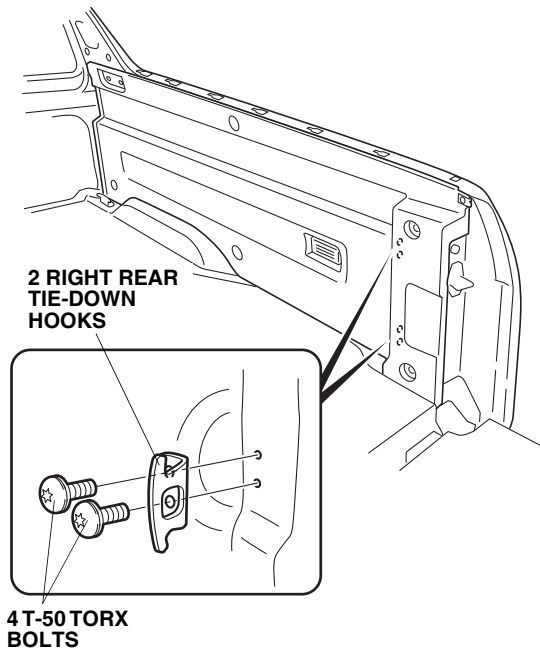

If the vehicle is equipped with a bed extender, continue with step 48; if not, go to step 49.

48. Remove the right latch (three hex bolts).

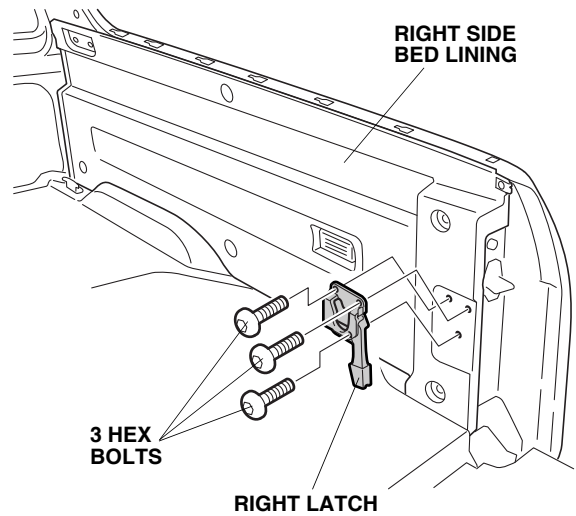

49. Remove the right side bed lining (five T-40 torx bolts, one clip, and unplug the vehicle connector).

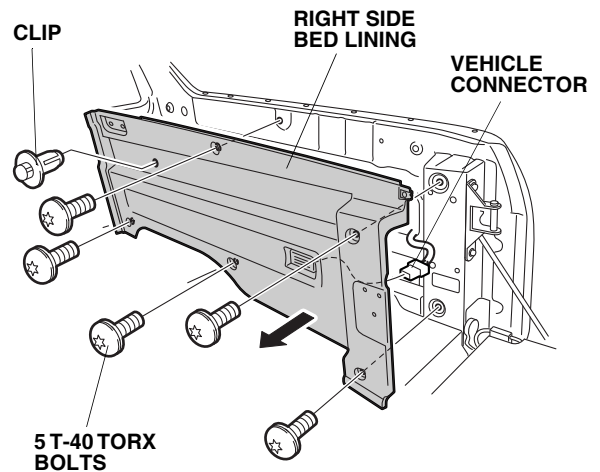

50. Remove the left taillight (two bolts, two clips, release the vehicle connectors from the vehicle panel, and unplug the vehicle connector). Repeat the same procedure for the right side.

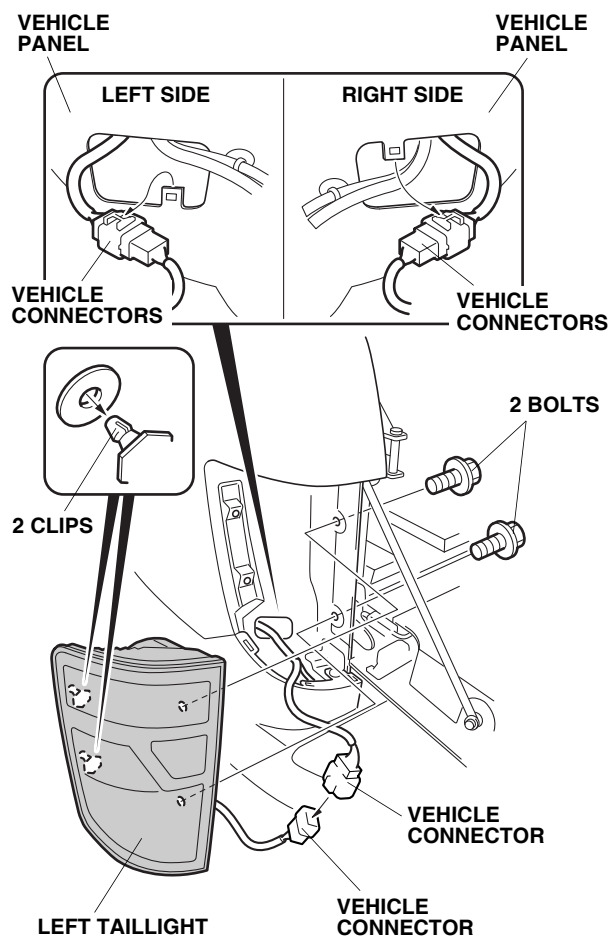

51. Remove the right license plate light (three retaining tabs and unplug the vehicle connector). Repeat the same procedure for the left side.

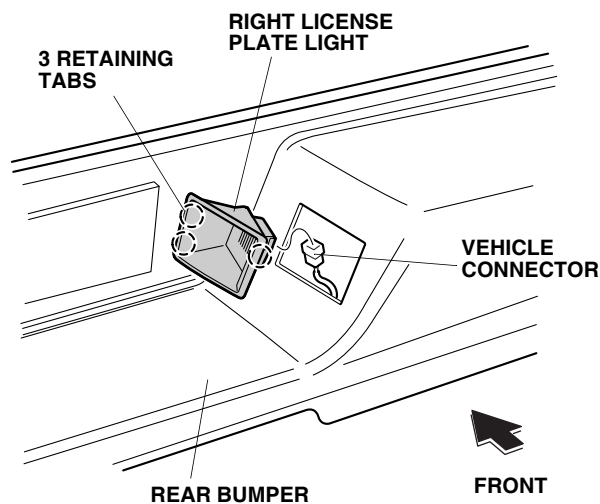

52. Remove the license plate from the rear bumper (two bolts).
53. Remove the rear bumper (two bolts, ten self-tapping screws, and six clips). Have an assistant help you. Place the rear bumper on a blanket.

With rear under spoiler

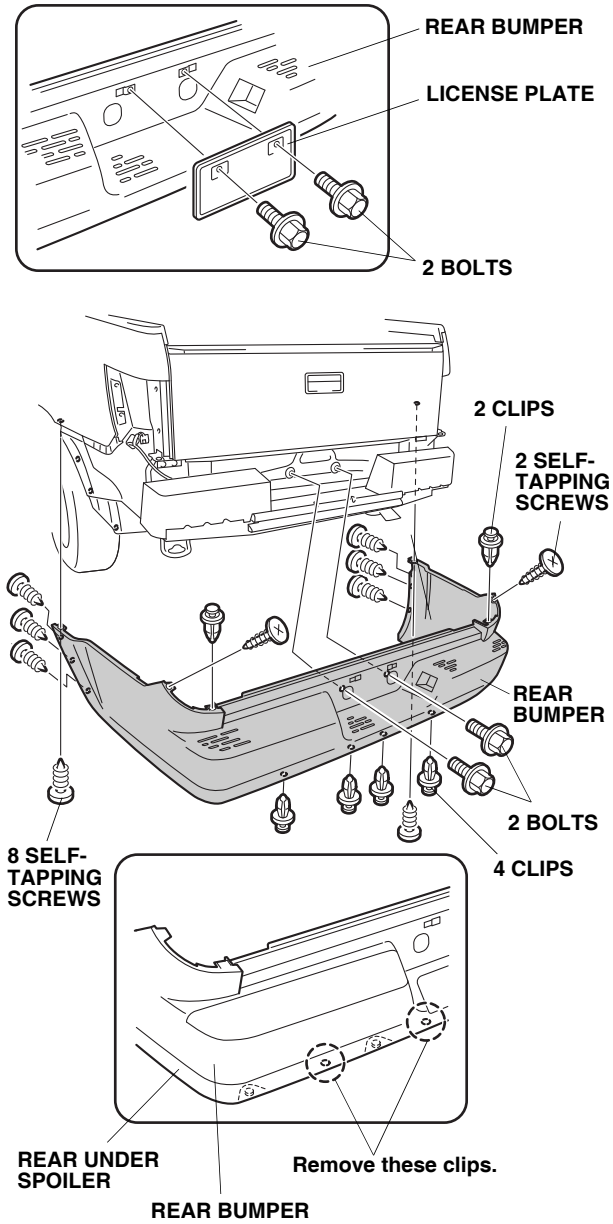

Without rear under spoiler

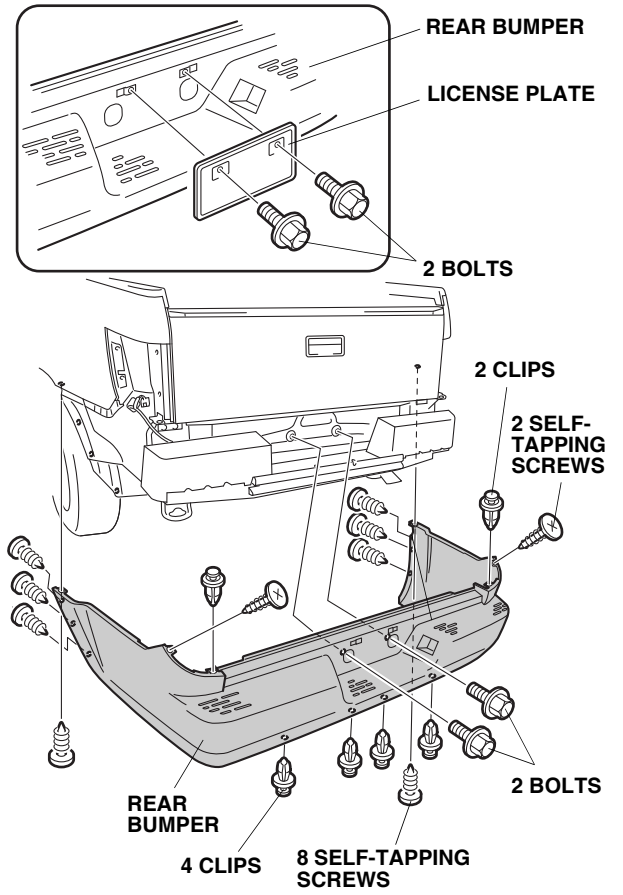

Cutting the Rear Bumper and the Bumper Absorbers

54. On the inside of the rear bumper, locate the back-up sensor preset marks on the left side. Using a pushpin, pierce the holes at the left and center preset marks. There are two sets of marks on the rear bumper, use the lower marks. Repeat the same procedure for the right side.

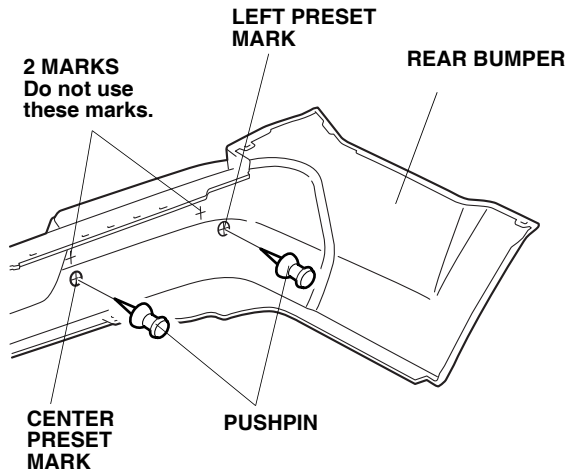

55. While wearing eye protection, drill one 20 mm hole through the outer mark, and one 26 mm hole through the inner mark on the rear bumper. First drill with a 3 mm drill bit, then finish the outer hole with a 20 mm hole saw and finish the inner hole with a 26 mm hole saw. Remove any burrs. Repeat the same procedure for the right side.

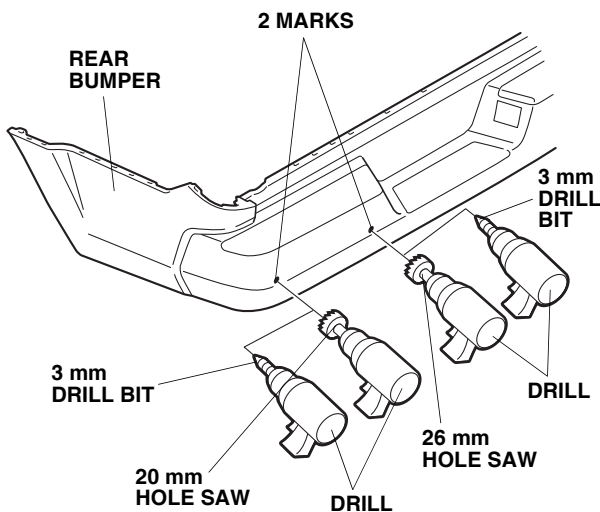

If the vehicle is equipped with a rear under spoiler, continue with step 56; if not, go to step 57.

56. Remove the left and right bumper absorber. Locate the scribe mark on the left bumper absorber. Using an utility knife, cut out the left bumper absorber along the scribe mark as shown. Repeat the same procedure for the right bumper absorber. Go to step 58.

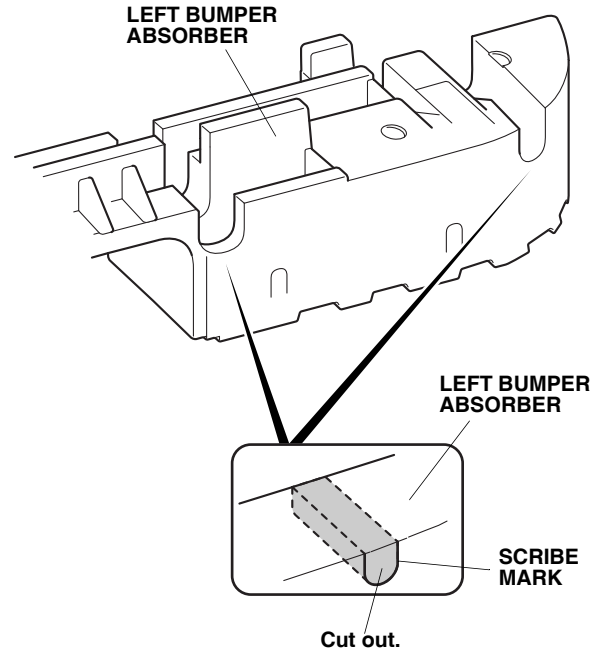

57. Remove the left and right bumper absorber. Locate the scribe mark on the left bumper absorber. Using an utility knife, measure and cut out the left bumper absorber along the scribe mark as shown. Repeat the same procedure for the right bumper absorber.

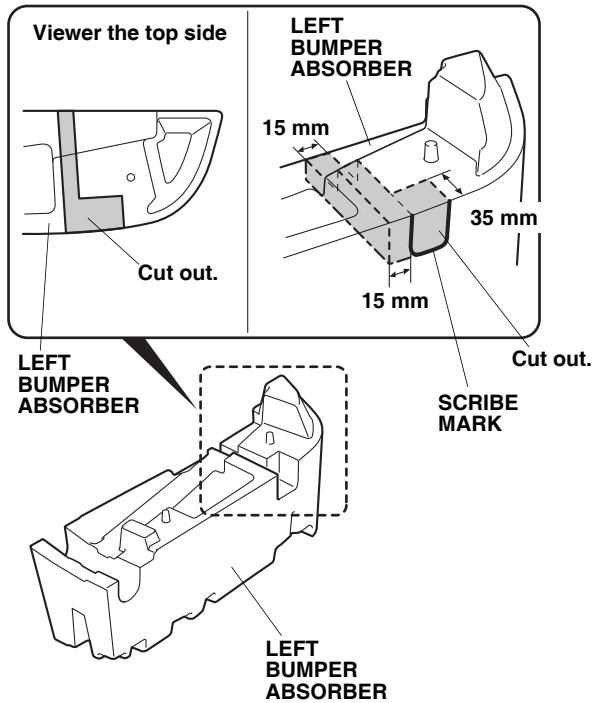

Installing the Sensors

58. Slide the two center sensors into the 26 mm holes with the "UP" mark facing up. Secure the center sensors with two retainer clips.

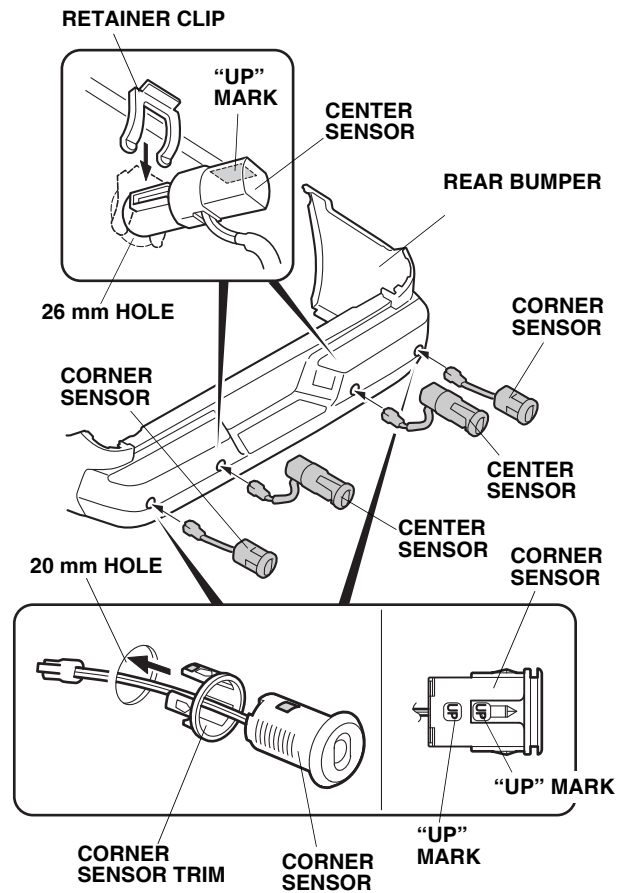

59. Separate the corner sensors from the corner sensor trims. First install the corner sensor trim into the 20 mm holes with the "UP" mark facing up, then install the corner sensors through the corner sensor trim with the "UP" mark on the sensor facing up.

Installing the Tailgate Switch

60. At the tailgate latch, place a shop towel along the tailgate latch to catch any metal shavings. Attach adhesive tape inside the tailgate panel with the tape adhesive facing up to catch any metal shaving.

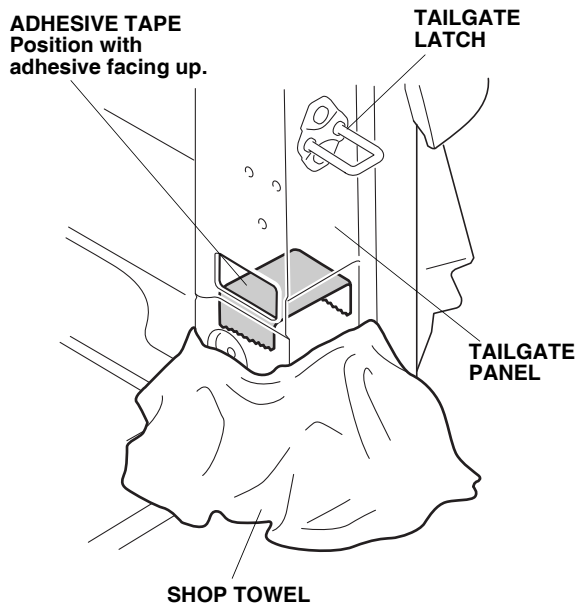

61. Position the template on the tailgate panel. Using a center punch, mark the tailgate panel at five holes indicated on the template. Remove the template.

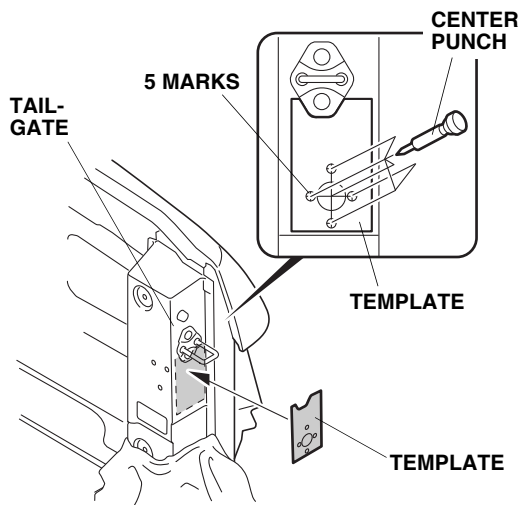

62. While wearing gloves and eye protection, drill one 26 mm hole and four 8 mm holes through the marked locations. First drill with a 3 mm drill bit, then finish the center hole with a 26 mm hole saw and the outer holes with an 8 mm drill bit.

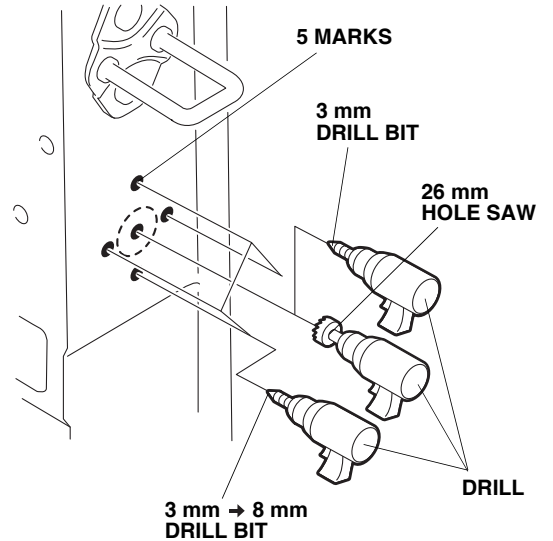

63. Remove the any burrs from the edges of holes, and apply touch-up paint on the holes. Allow the touch-up paint to dry thoroughly before proceeding to the next step. Remove the shop towel, adhesive tape, and any metal shavings.

64. Insert two well nuts into the upper and lower holes.

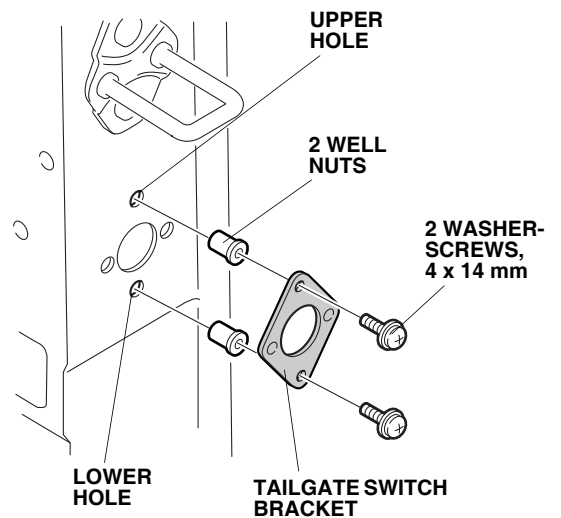

65. Install the tailgate switch bracket to the vehicle with two 4 x 14 mm washer-screws.

66. Cut 50 mm from the end of the corrugated tube.

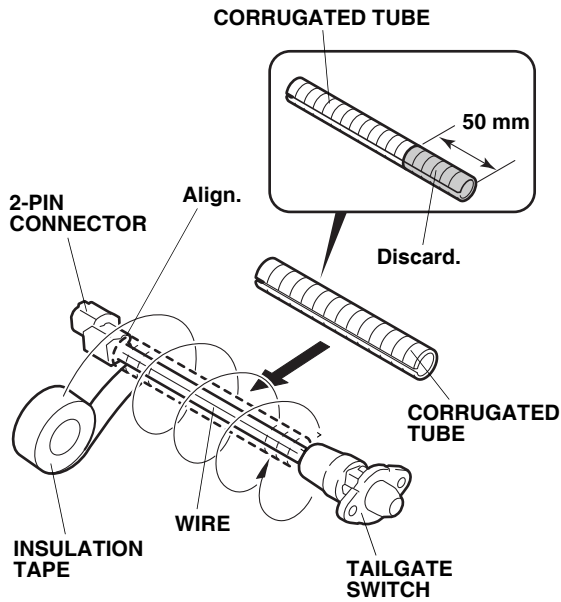

67. Attach the corrugated tube to the wires of the tailgate switch, align the corrugated tube to the 2-pin connector, and secure the tube to the tailgate switch with an insulation tape.
68. Insert the tailgate switch 2-pin connector into the 26 mm hole, and install the tailgate switch onto the tailgate switch bracket with two 4 x 14 mm washer-screws.

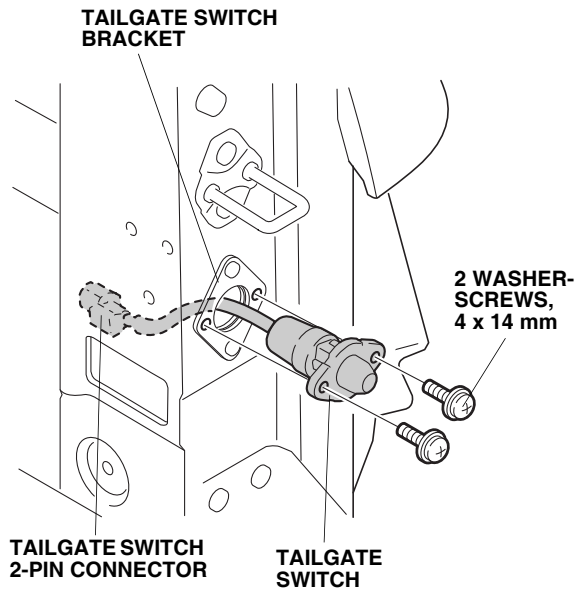

Routing the Back-up Sensor Harness

69. Attach the 2A fuse label to the back-up sensor harness fuse case.

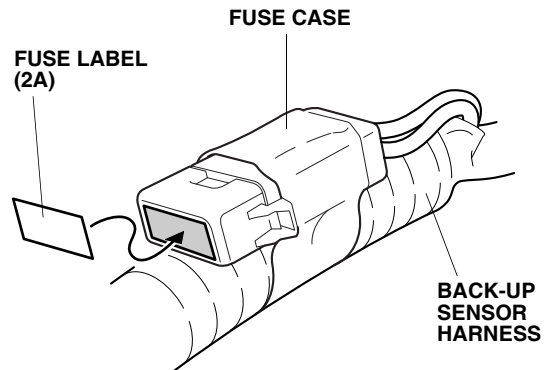

70. Inside the passenger's compartment, remove the two vehicle foam blocks from the vehicle panel.

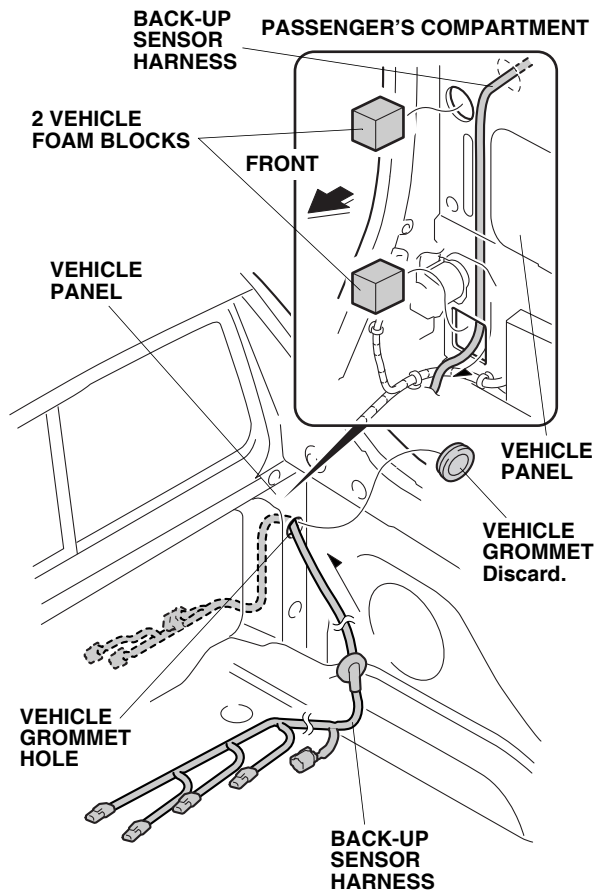

71. Inside the cargo area, remove the vehicle grommet from the vehicle panel.
72. Route the back-up sensor harness into the vehicle grommet hole, and into the passenger's compartment.

73. Install the back-up sensor harness grommet into the vehicle grommet hole.

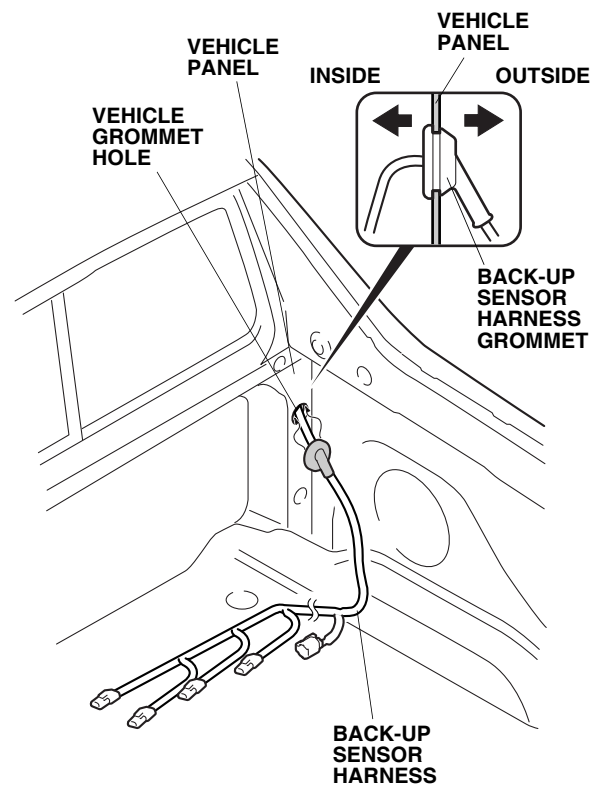

74. Inside the cargo area, route the back-up sensor harness along the vehicle harness, and secure the front of the back-up sensor harness to the hole on the vehicle panel with one wire tie with small clip. Align the wire tie with small clip to the green tape on the back-up sensor harness as shown.

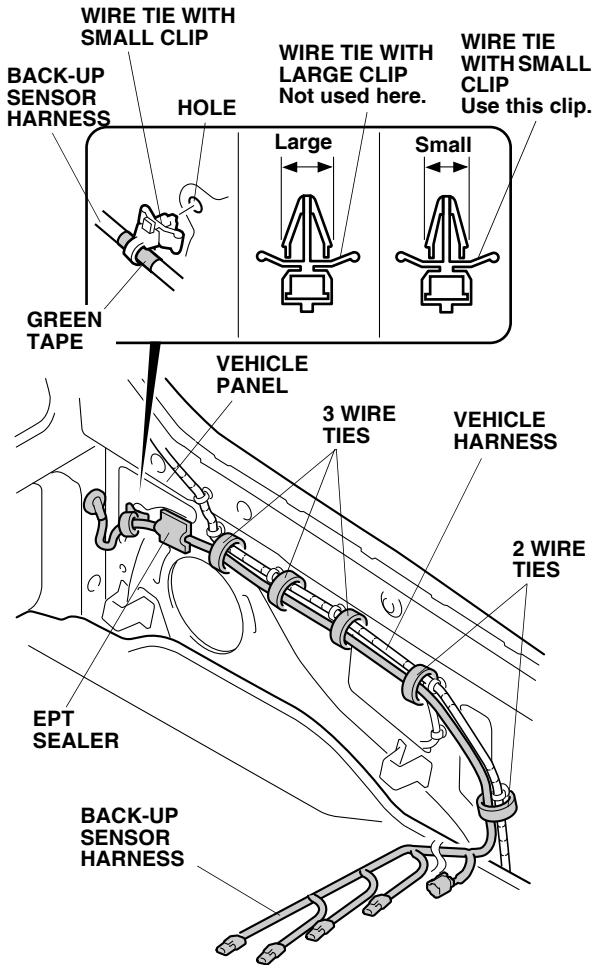

75. Secure the back-up sensor harness to the vehicle harness with five wire ties.
76. Using isopropyl alcohol on a shop towel, clean the area near the wire tie with small clip where the EPT sealer will attach. Secure the back-up sensor harness to the vehicle panel with one EPT sealer.

77. Route the back-up sensor harness along the vehicle harness, and through the right taillight opening. Secure the back-up sensor harness to the vehicle harness with three wire ties.

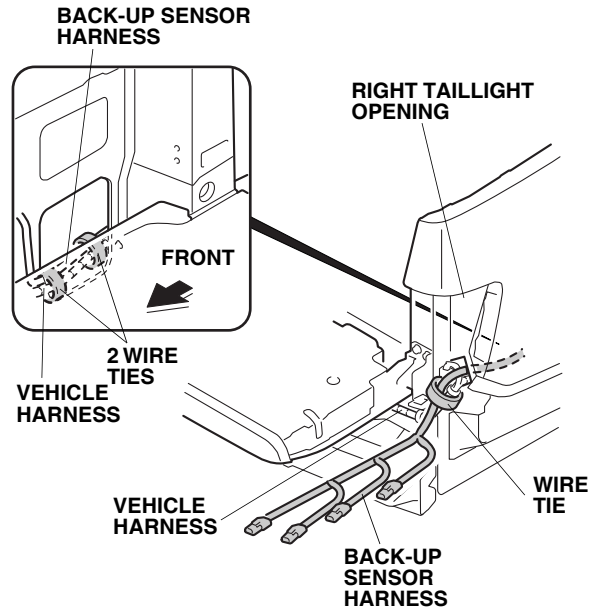

78. Using scissors, cut a EPT sealer into three equal pieces.

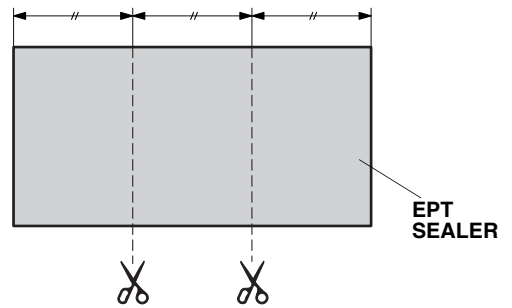

79. Using isopropyl alcohol on a shop towel, clean the areas where the EPT sealers will attach. Attach two pieces of EPT sealer to the edge of the vehicle panel as shown.

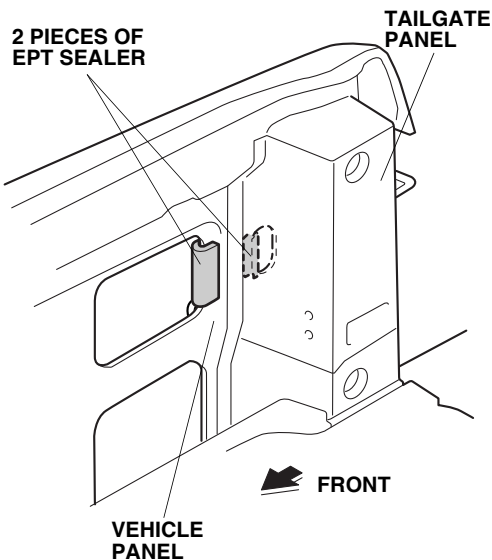

80. Plug the back-up sensor harness 2-pin connector into the tailgate switch 2-pin connector.

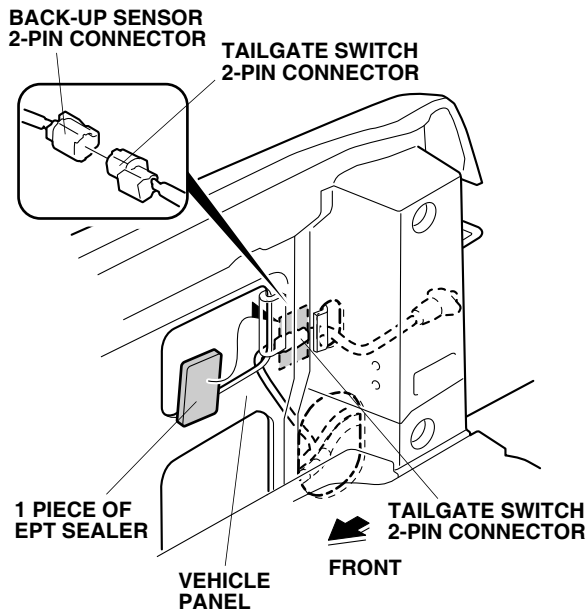

81. Using isopropyl alcohol on a shop towel, clean the area where the EPT sealer will attach. Secure the back-up sensor harness to the vehicle frame with one piece of EPT sealer.

82. Route the back-up sensor harness along the rear bumper area, and secure it to the vehicle harness with eight wire ties.

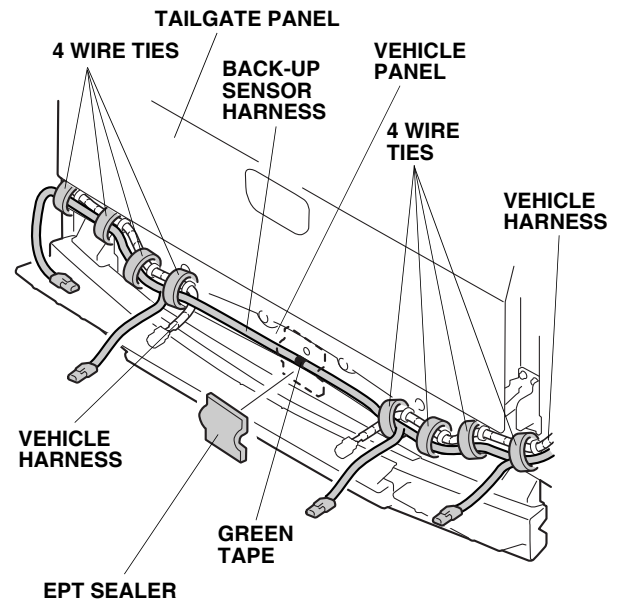

83. Using isopropyl alcohol on a shop towel, clean the area where the EPT sealer will attach. Secure the back-up sensor harness to the vehicle panel with one EPT sealer at the green tape.

84. Using scissors, cut one EPT sealer in half.

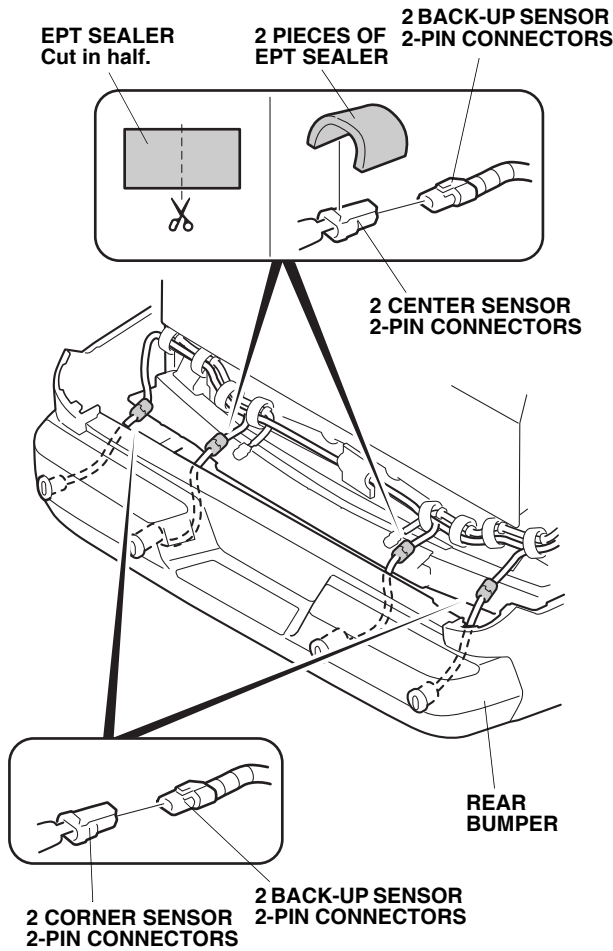

85. Reinstall the bumper absorber. With the help of an assistant, hold the rear bumper close to the vehicle. Route the back-up sensor harness 2-pin connectors through the holes in the bumper absorber, and plug them to the corner sensor and the center sensor 2-pin connectors.

86. Wrap two pieces of EPT sealer around the center sensor 2-pin connectors, and reinstall the rear bumper.

87. Under the rear bumper, secure the center sensor 2-pin connectors and the center sensor harnesses to the vehicle brackets with two wire ties with large clip as shown.

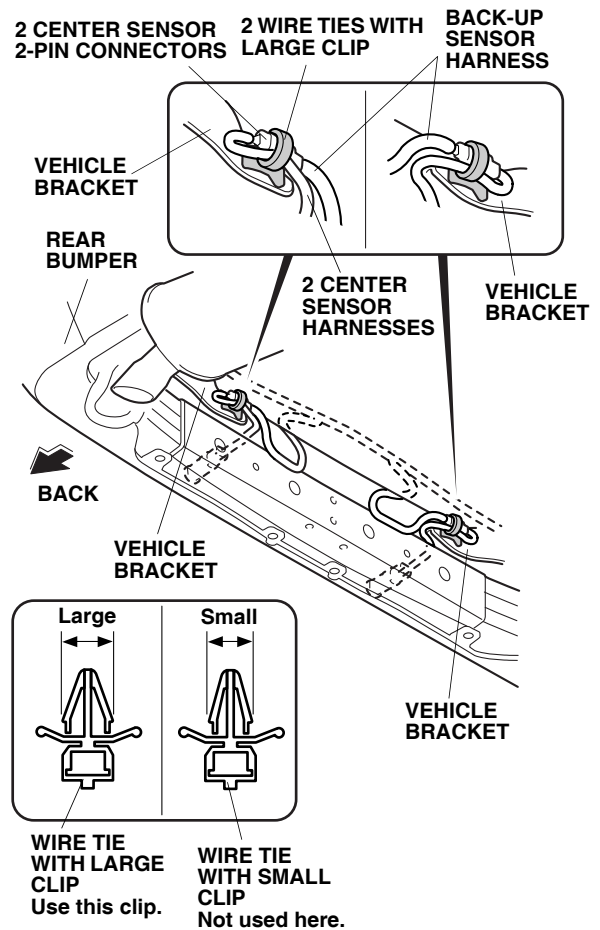

88. Inside of the vehicle, turn over the floor mat, and route the back-up sensor harness across the vehicle panel and alongside the vehicle harness.

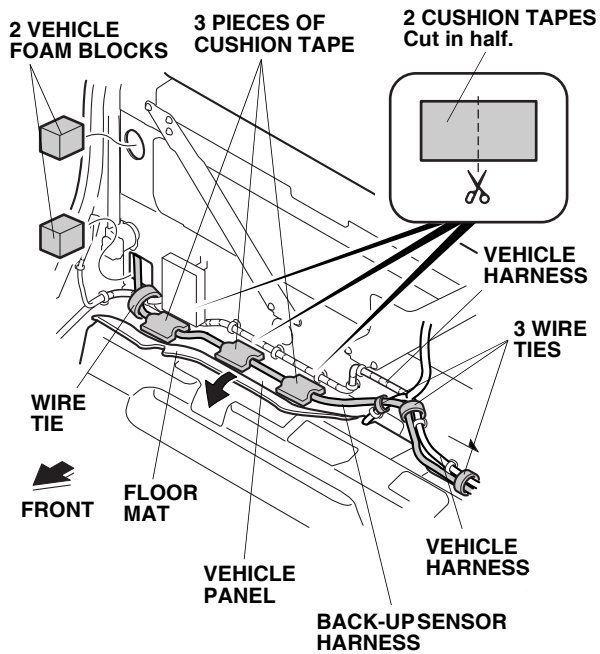

89. Using scissors, cut two cushion tapes in half. Using isopropyl alcohol on a shop towel, clean the areas where the cushion tapes will attach. Secure the back-up sensor harness to the vehicle panel with three pieces of cushion tape.
90. Secure the back-up sensor harness to the vehicle harness with four wire ties. Do not secure the wire tie to the SRS harness.
91. Reinstall the two vehicle foam blocks removed in step 70.

92. Slide the control unit bracket onto the control unit.

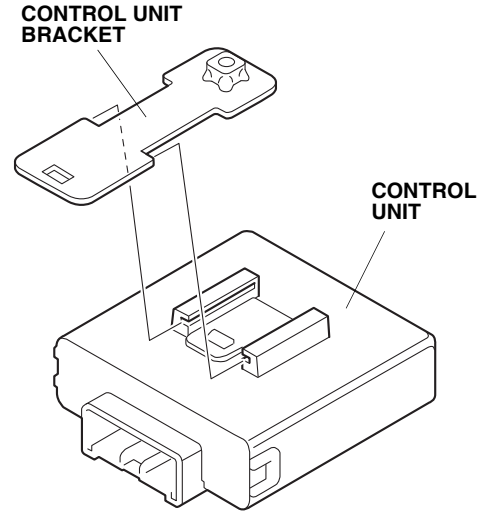

93. Plug the back-up sensor harness 22-pin connector into the control unit, and insert the control unit bracket into the hole on the vehicle panel. Secure the control unit bracket with one flange bolt.

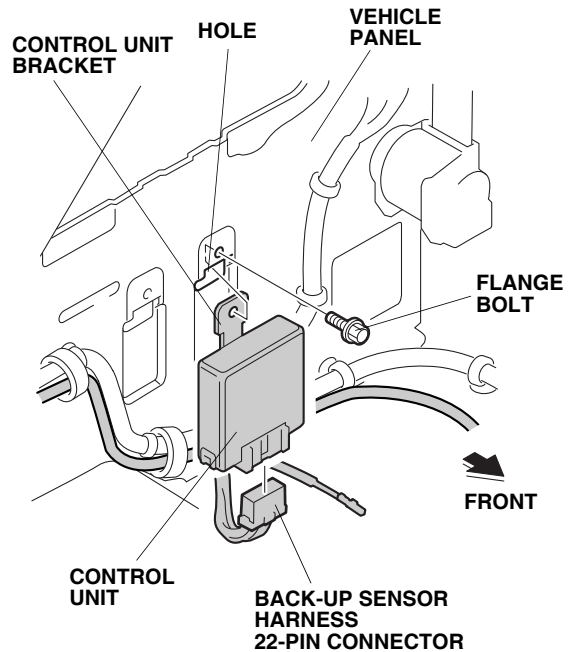

94. Unplug the vehicle 23-pin and 14-pin connectors. Release the connector lock on the vehicle 23-pin connector.

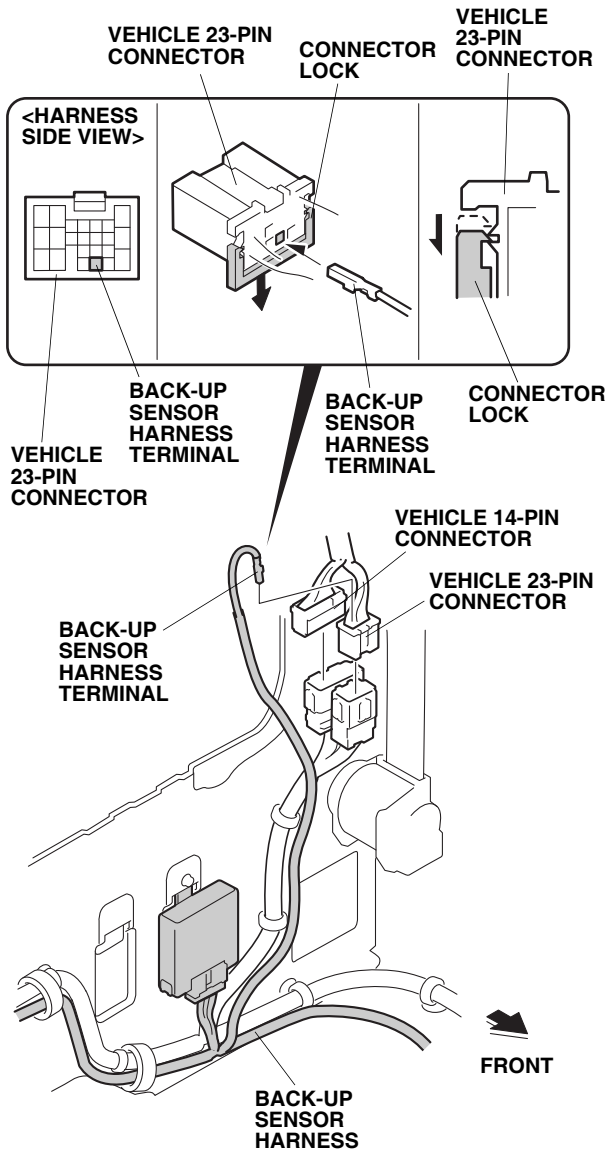

95. Push the back-up sensor harness terminal into vehicle 23-pin connector, then reattach the connector lock. Re-plug the vehicle 23-pin and 14-pin connectors.

96. Route the back-up sensor harness along the vehicle harness, and secure it to the vehicle harness with four wire ties and two small wire ties in the area shown.

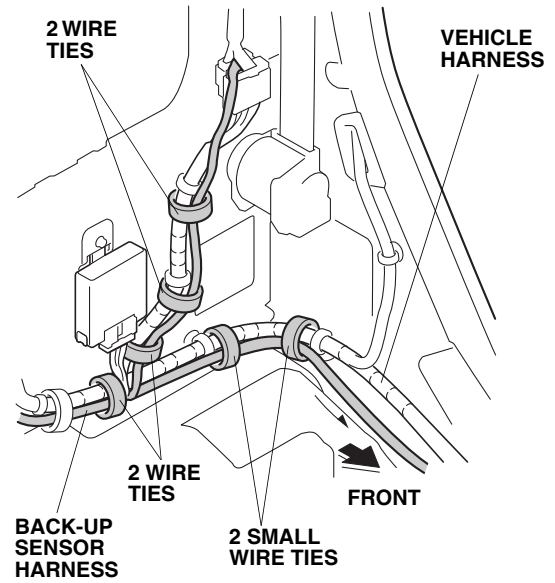

97. Route the back-up sensor harness along the vehicle harness, and secure it to the vehicle harness with four small wire ties.

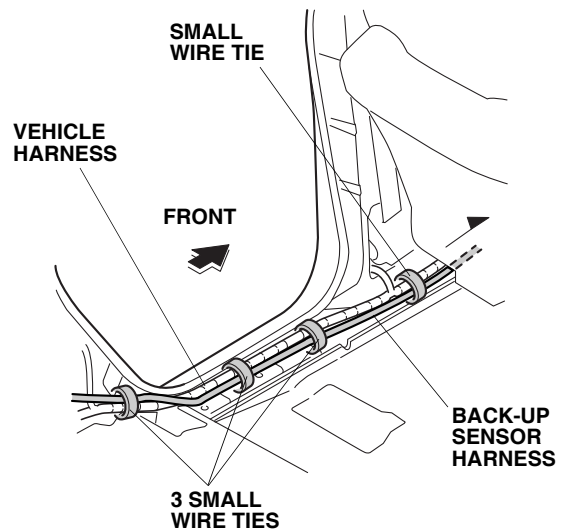

98. Route the back-up sensor harness along the vehicle harness, and secure it to the vehicle harness with three small wire ties.

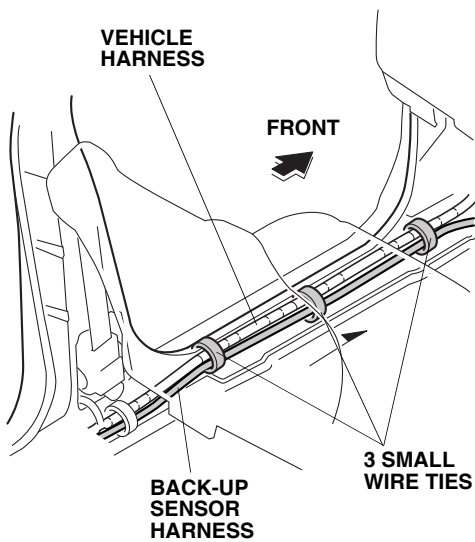

99. At the fuse box, remove the upper hood opener bolt. Secure the back-up sensor harness ground terminal with the ground bolt.

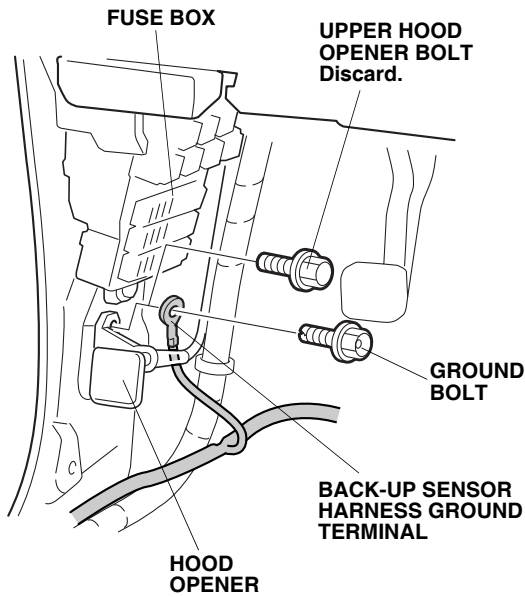

100. Route the back-up sensor harness as shown, and secure it to the vehicle harness and the vehicle frame with six wire ties.

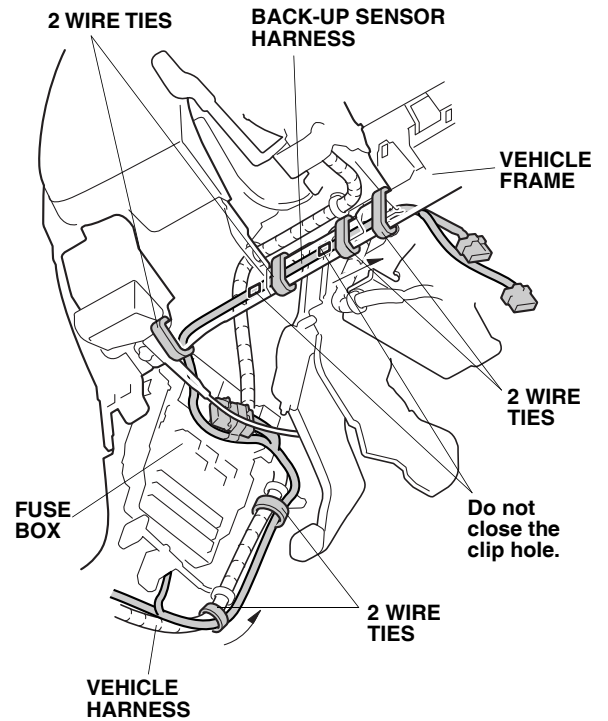

- If the vehicle is equipped with the security system:**
Wrap one cushion tape around the back-up sensor harness, and secure it to the security system bracket with one wire tie.

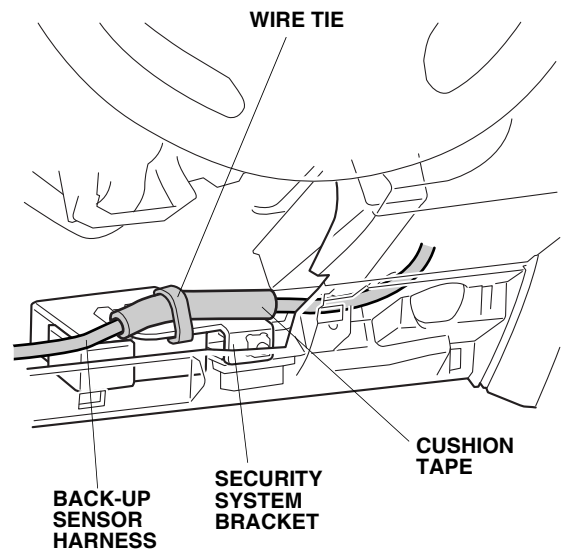

101. Route the back-up sensor harness along the vehicle harness, and secure it to the vehicle harness with three wire ties. If there is any excess, bundle it to the vehicle harness after step 105.

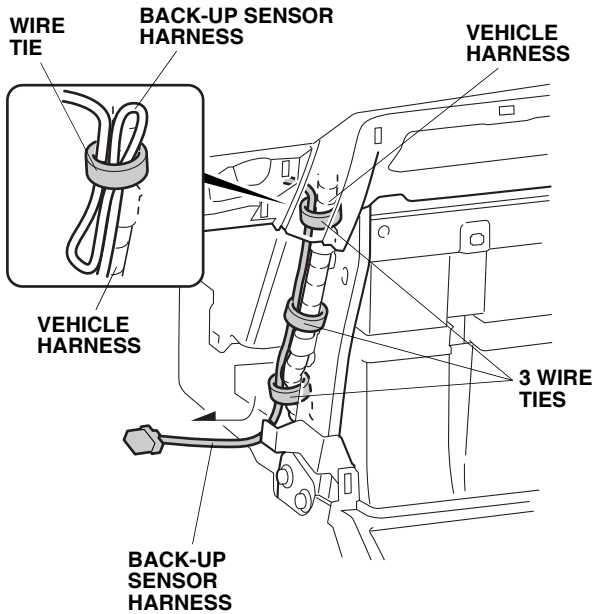

102. Install the buzzer bracket to the buzzer with one 6 x 12 mm washer-screw and one flange nut. Do not pinch the wire on the buzzer.

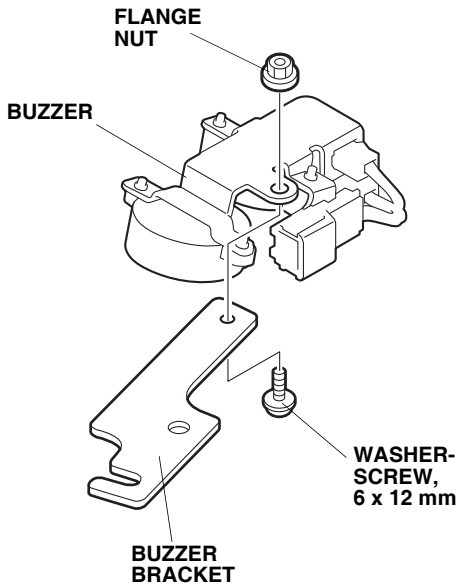

103. Remove the front vehicle bolt from the vehicle frame, and loosen the back vehicle bolt.

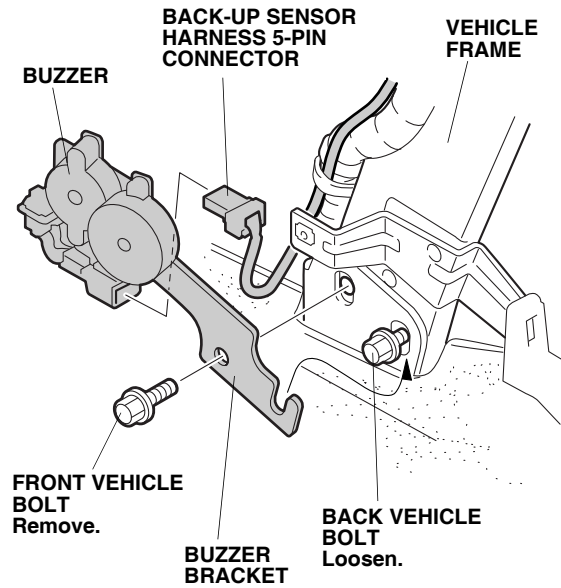

104. Plug the back-up sensor harness 5-pin connector into the buzzer.
105. Insert the buzzer bracket between the vehicle frame and the back vehicle bolt, and install the buzzer bracket to the vehicle frame with two bolts.

Installing the Switch

106. Using a pushpin, mark the inside of the driver's dashboard lower cover at the preset mark.

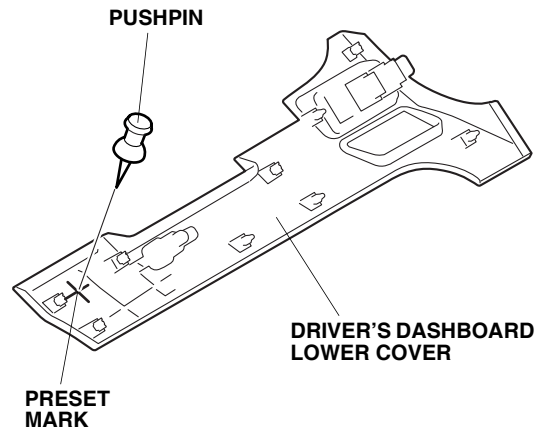

107. While wearing eye protection, drill one 26 mm hole through the marked position. First drill with a 3 mm drill bit, then finish with a 26 mm hole saw. Remove any burrs.

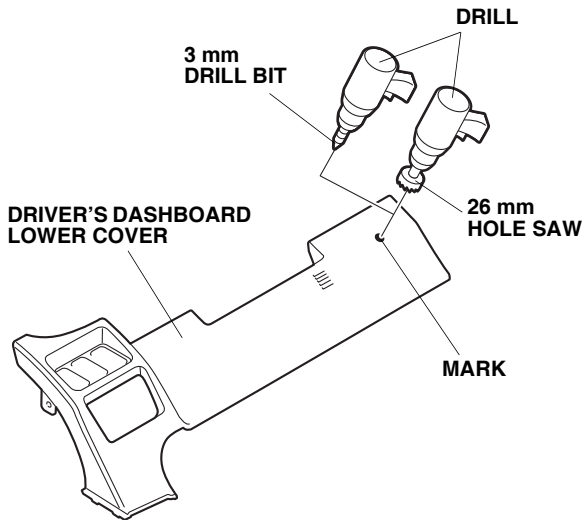

108. Reinstall the driver's dashboard lower cover. Insert the switch connector into the hole of the driver's dashboard lower cover, then turn the switch to install it to the driver's dashboard lower cover.

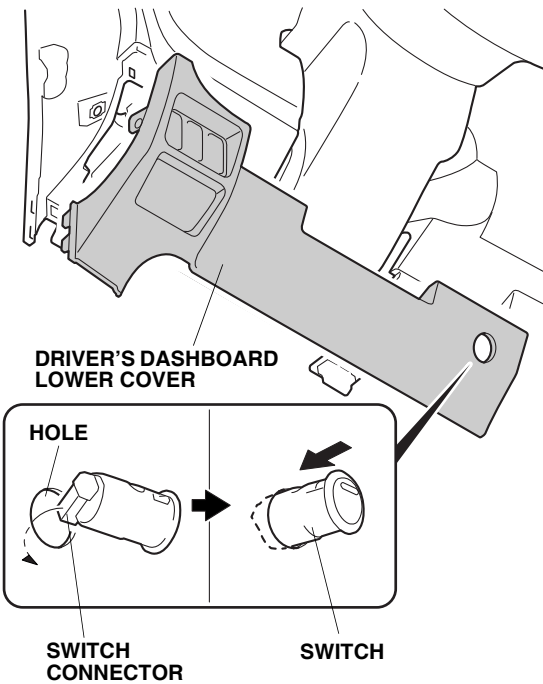

109. Plug the back-up sensor harness 3-pin connector into the switch.

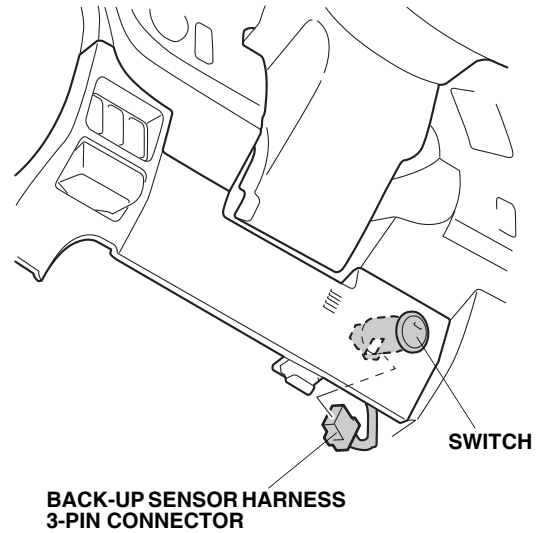

110. Using isopropyl alcohol on a shop towel, clean the area where the EPT sealer will attach. Attach the EPT sealer to the driver's console side trim in the area shown.

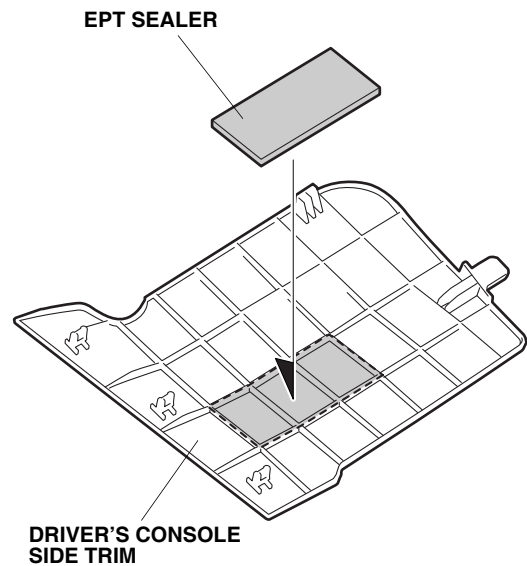

111. Check that all wire harnesses are routed properly and all connectors are plugged in.
112. Reinstall all removed parts. Check that all clips and fasteners are installed securely.

NOTE:

- Torque the seat belt upper anchor bolts (steps 25 and 28) to 32 N•m (24 lb-ft).
- Use these torque specs when reinstalling the anchor bolts to the rear seat (step 21):
 - Rear seat belt anchor bolt, 32 N•m (24 lb-ft)
 - 6 rear seat belt buckle anchor bolts, 22 N•m (16 lb-ft)
 - 2 rear seat anchor bolts, 47 N•m (35 lb-ft)
- If reinstalling the left seat belt lower anchor bolt cover (step 12), torque the bolt to 32 N•m (24 lb-ft).

113. Reconnect the negative cable to the battery.
114. Enter the customer's radio anti-theft code, and reset the radio station presets.
115. Reset the clock.
116. Check the operation of the back-up sensors according to the User's Information Manual.

NOTE: Whenever the battery is disconnected, the driver's AUTO function is disabled.

117. Start the engine. Push down on the driver's window switch until the window is fully open.
118. Pull up on the driver's window switch fully to close the window completely, then hold the switch for 2 seconds or more.
119. Test the window AUTO function.