



INSTALLATION INSTRUCTIONS

Accessory
FRONT TRIM
P/N 08P01-SZA-100

Application
2010 PILOT

Publications No.
All 41652
Issue Date
JUL 2009

NOTE: The front trim cannot be installed on vehicle equipped with the full nose mask or front lower garnish.

PARTS LIST

Front trim

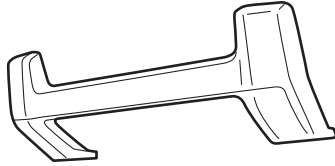

Front license frame

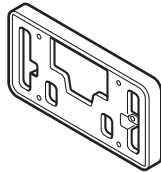

4 Spring nuts



18 Washer-bolts



TOOLS AND SUPPLIES REQUIRED

Phillips screwdriver

Ratchet

Socket

Pushpin

Drill

3 mm, 6 mm and 10 mm Drill bits

19 mm Hole saw (Hole saw kit: AKS052507)

Eye protection (safety goggles, face shield, etc.)

Blanket

Illustration of the Front Trim Kit Installed on the Vehicle

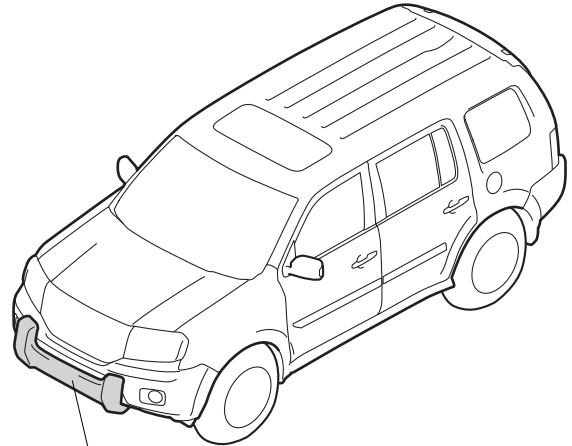

FRONT TRIM

INSTALLATION

Customer Information: The information in this installation instruction is intended for use only by skilled technicians who have the proper tools, equipment, and training to correctly and safely add equipment to your vehicle. These procedures should not be attempted by "do-it-yourselfers."

NOTE: Be careful not to damage the body paint finish. To prevent damage, place a blanket under the front bumper during the installation.

1. Remove the front bulkhead cover (nine clips).

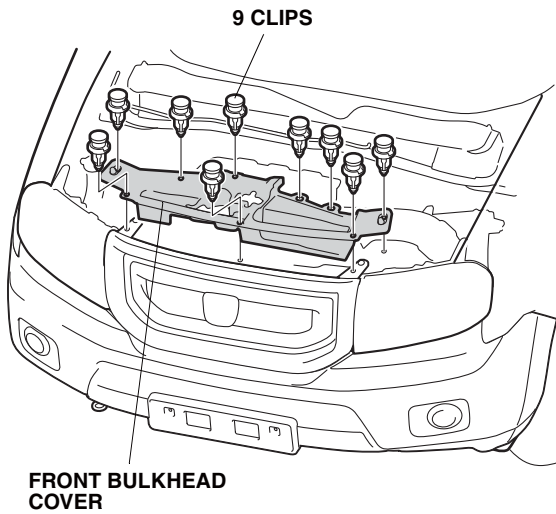

2. Remove the front bumper (nine clips, four bolts, and four self-tapping screws). Have an assistant help you when removing and installing the front bumper. If the vehicle is equipped with the foglight or the front corner sensors, unplug the connectors.

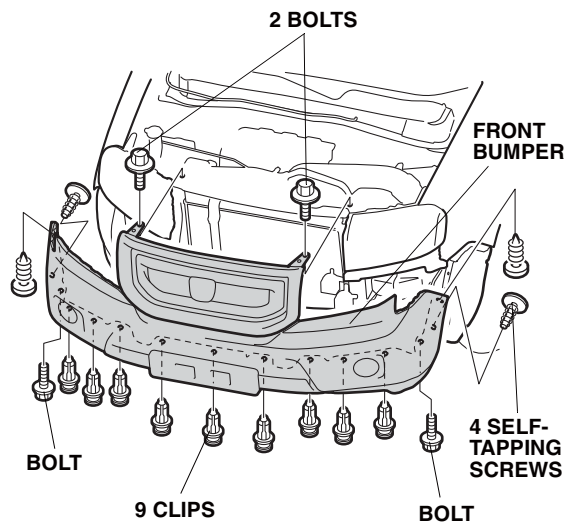

3. Remove the bumper grille from the front upper bumper and the front lower bumper (sixteen hooks).

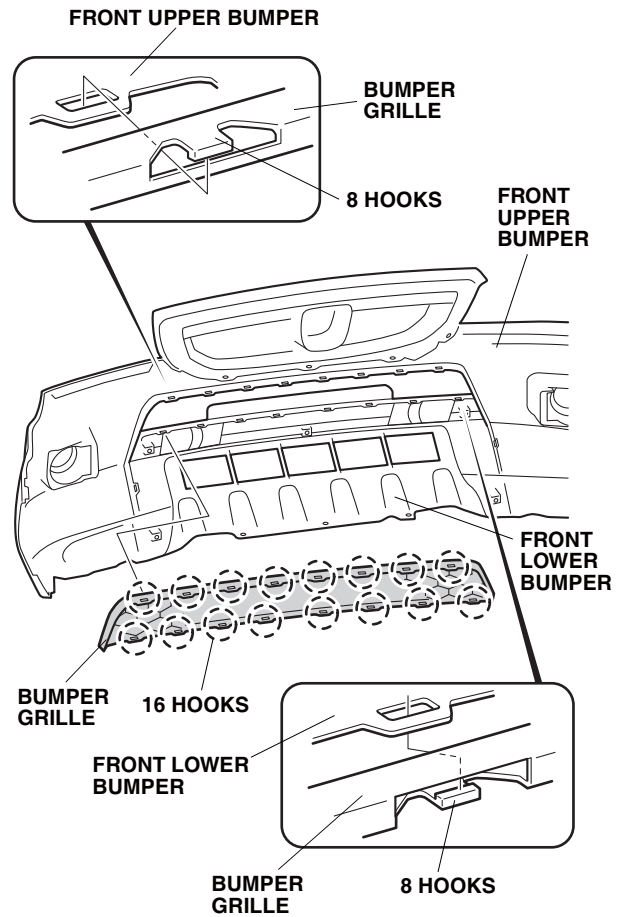

- Remove the front lower bumper from the front upper bumper (five self-tapping screws and two hooks).

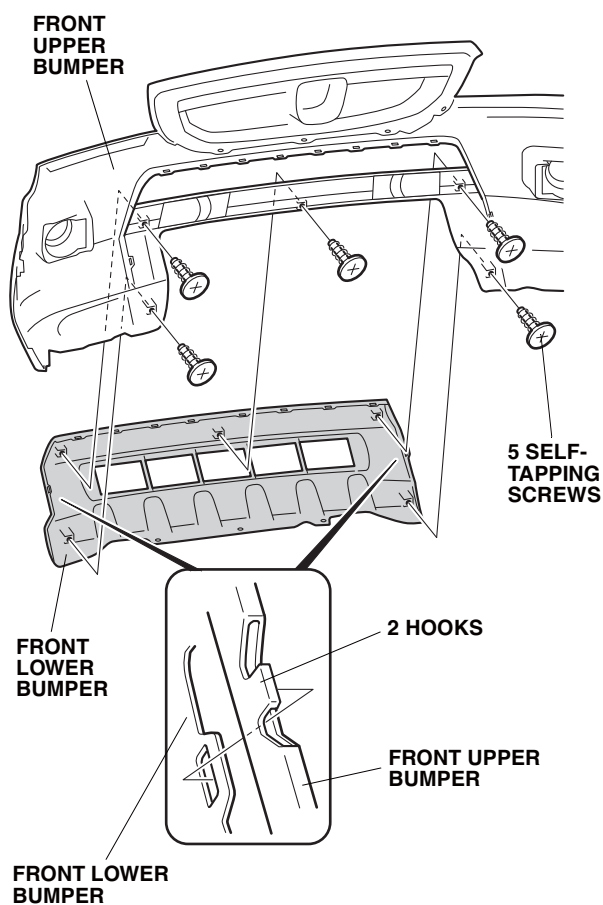

- Inside the front lower bumper, mark the center of the six scribe marks with a pushpin as shown.

NOTE: There are several marks on the inner side of the front lower bumper. Make sure that you locate the proper cross marks.

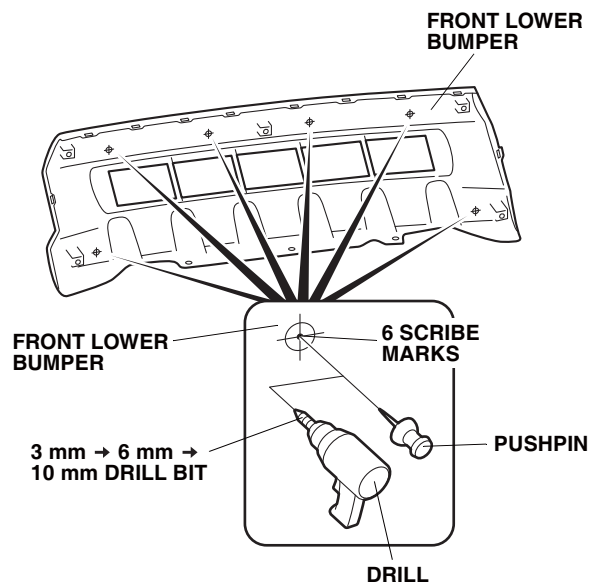

- While wearing eye protection, first drill with a 3 mm drill bit, second drill with a 6 mm drill bit, and finish with a 10 mm drill bit, and remove all burrs.

7. Inside the front upper bumper, mark the center of the six scribe marks with a pushpin as shown.

NOTE: There are several marks on the inner side of the front upper bumper. Make sure that you locate the proper cross marks.

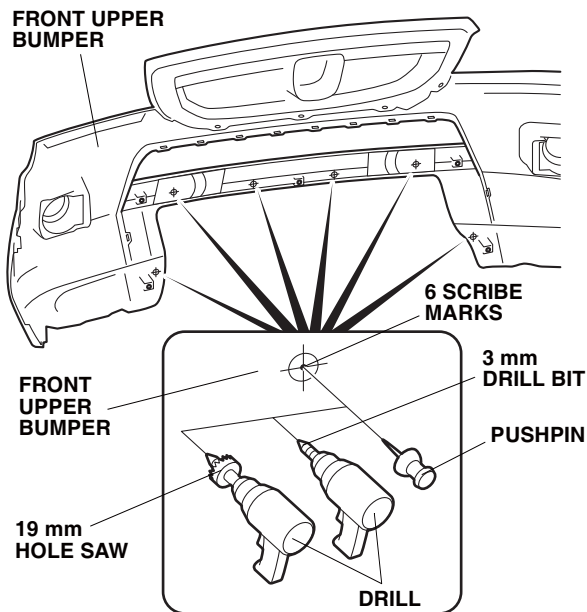

8. While wearing eye protection, drill a 3 mm hole at each of the pierced points you made from the inside of the front upper bumper as shown.
9. Enlarge 3 mm holes with a 19 mm hole saw, and remove all burrs.

10. Reinstall the front lower bumper and bumper grille to the front upper bumper.

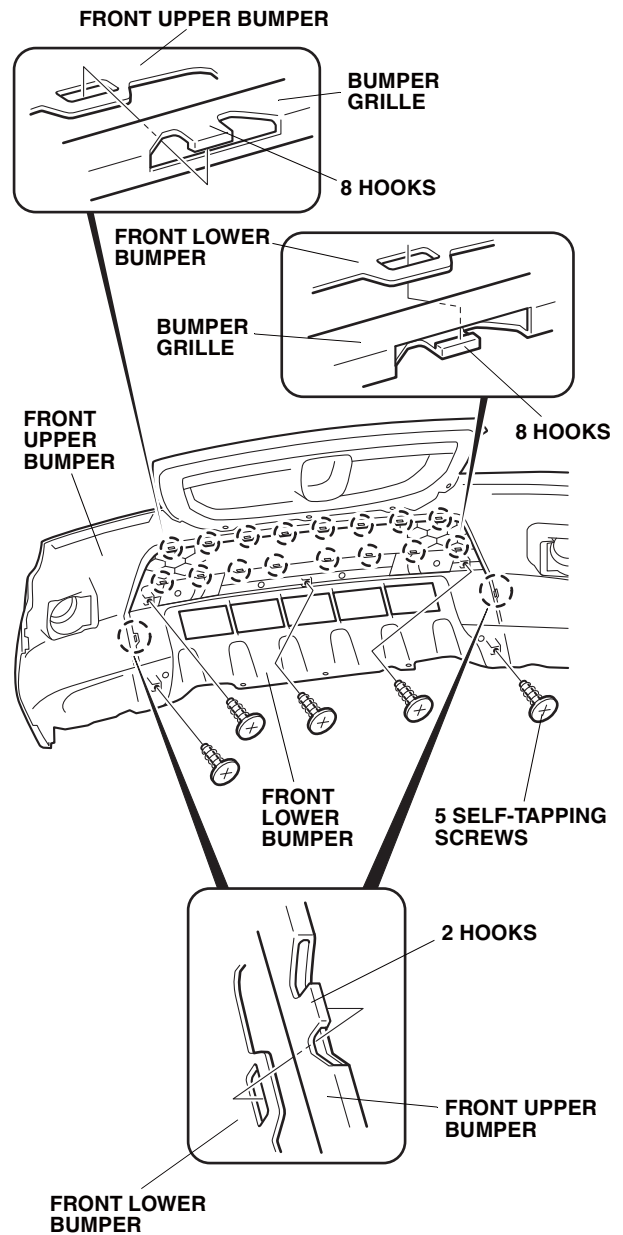

11. Inside the front bumper, mark the center of the eight scribe marks with a pushpin as shown.

NOTE: There are several marks on the inner side of the front bumper. Make sure that you locate the proper cross marks.

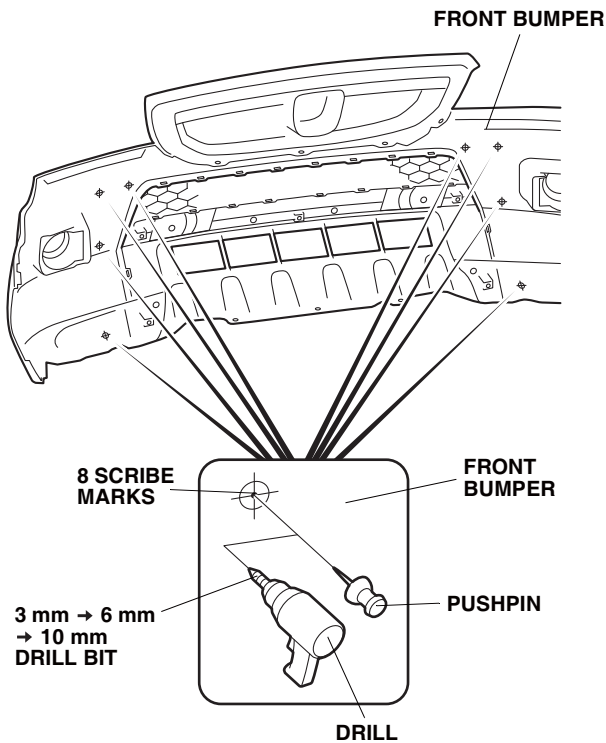

12. While wearing eye protection, first drill with a 3 mm drill bit, second drill with a 6 mm drill bit, and finish with a 10 mm drill bit, and remove all burrs.

For states requiring the front license plate, continue with steps 13 through 16; if not, go to step 17.

13. Inside the front trim, mark the center of the four scribe marks with a pushpin as shown.

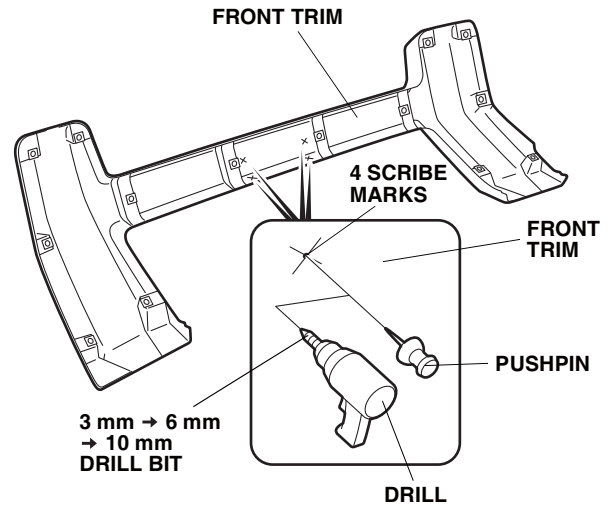

14. While wearing eye protection, first drill with a 3 mm drill bit, second drill with a 6 mm drill bit, and finish with a 10 mm drill bit, and remove all burrs.

15. Slide the four spring nuts to the front license frame as shown.

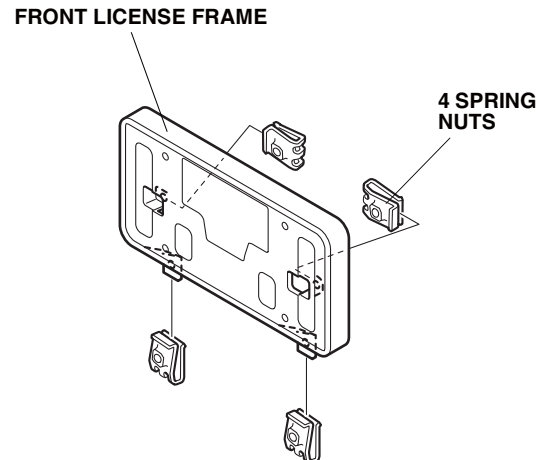

16. Install the front license frame to the front trim with four washer-bolts.

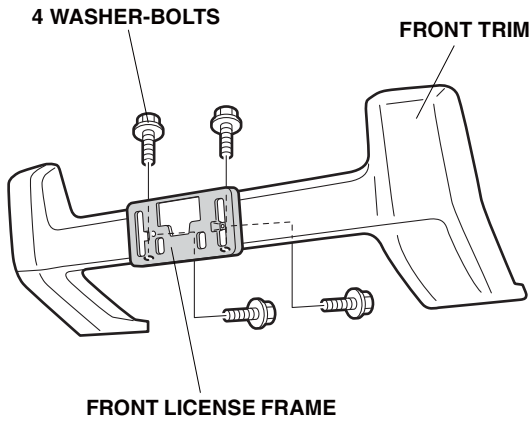

17. Loosely install the front trim to the front bumper with fourteen washer-bolts.

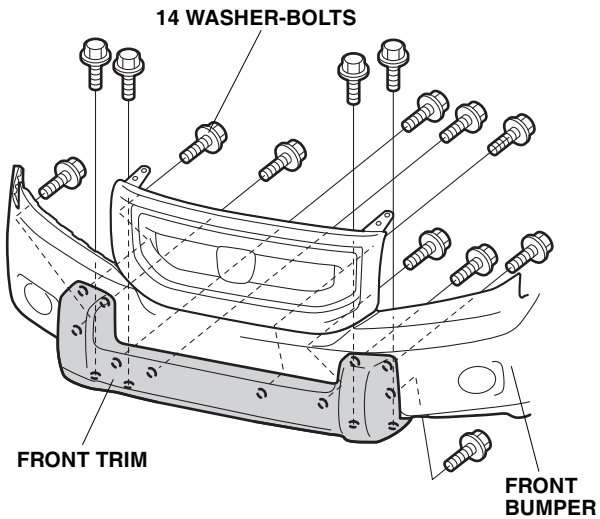

18. Confirm the front trim is installed properly, and adjust if necessary.
19. Tighten the washer-bolts loosely installed in step 17.

20. Reinstall the front bumper.

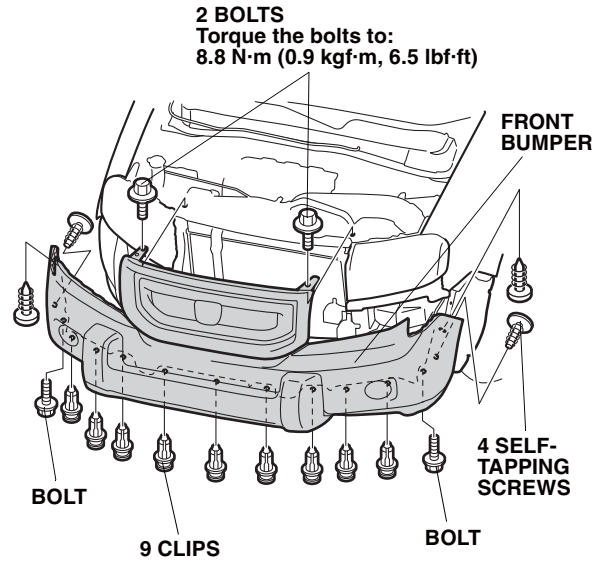

21. Reinstall all removed parts.