



INSTALLATION INSTRUCTIONS

Accessory
FRONT GRILLE
P/N 08F21-SZA-100

Application
2010 PILOT

Publications No.
All 41643
Issue Date
MAY 2009

PARTS LIST

Front Grille

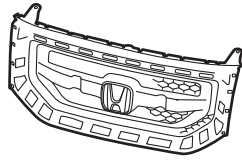

TOOL AND SUPPLIES REQUIRED

Phillips screwdriver

Flat-tip screwdriver

Plastic trim tool: T/N SILTRIMTL10

Utility Knife

File

Shop towel

Diagonal cutters

Blanket

Illustration of the Front Grille on the Vehicle

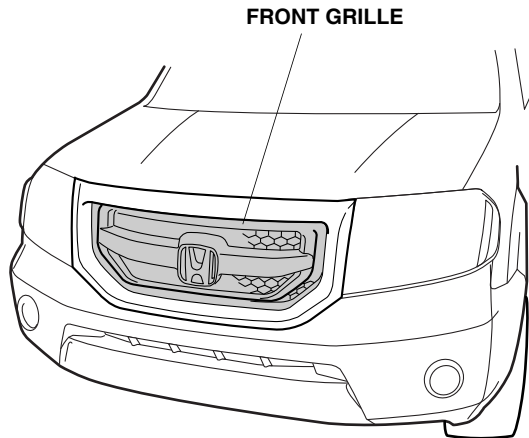

INSTALLATION

Customer Information: The information in this installation instruction is intended for use only by skilled technicians who have the proper tools, equipment, and training to correctly and safely add equipment to your vehicle. These procedures should not be attempted by "do-it-yourselfers."

NOTE:

- Do not damage the body paint finish when removing and installing the front grille.
- Before removing the parts of the vehicle, note the location of the parts and how they are installed so they can be reinstalled in the original positions securely.
- Release or remove the retaining tabs and clip from the part with care. Upon installation, secure the parts with the retaining tabs, clips, etc.

1. Remove the front bulkhead cover (nine clips).

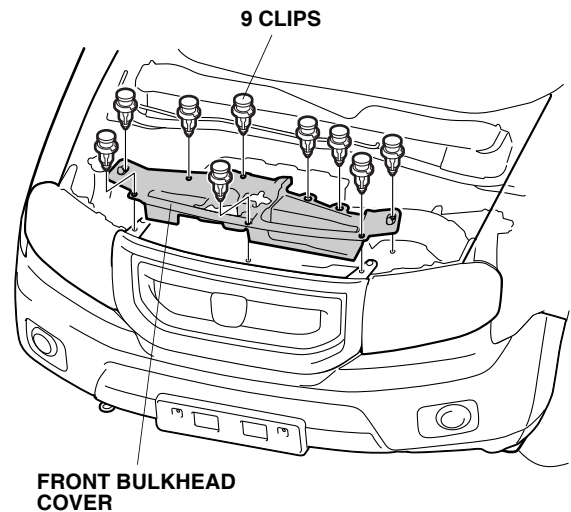

- Remove the front bumper (nine clips, four bolts, and four self-tapping screws). Have an assistant help you when removing the front bumper. If the vehicle is equipped with the foglights or the front corner sensors, unplug the connectors. Place the front bumper on the blanket after removal.

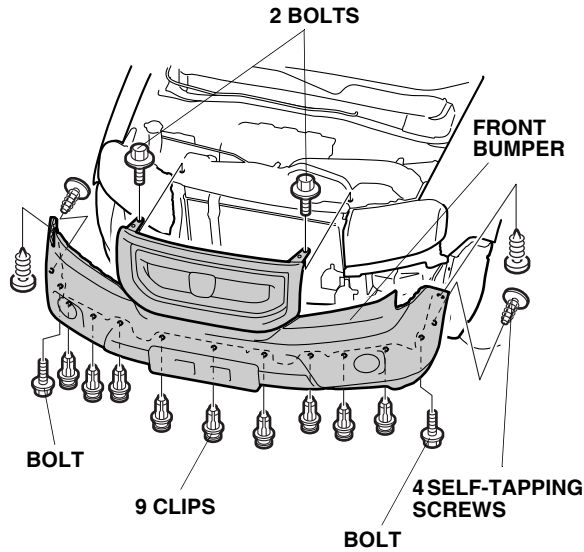

- Remove the vehicle front grille (five clips).

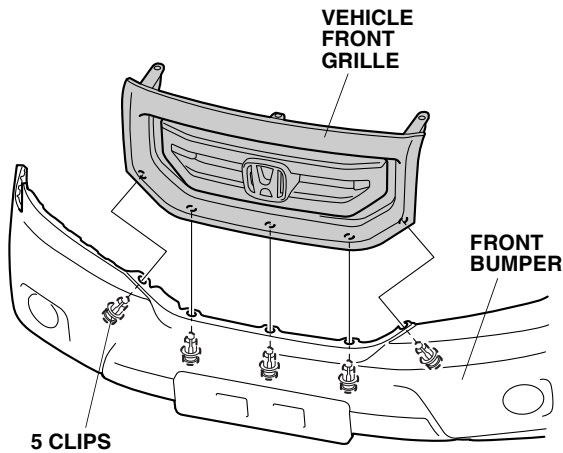

Separate the front grille from the front grille molding

- Inside the vehicle front grille, cut off fourteen areas on the vehicle front grille as shown. Do not damage the front grille molding tabs when cutting the vehicle front grille.

NOTE: Do not cut off the front grille molding tabs.

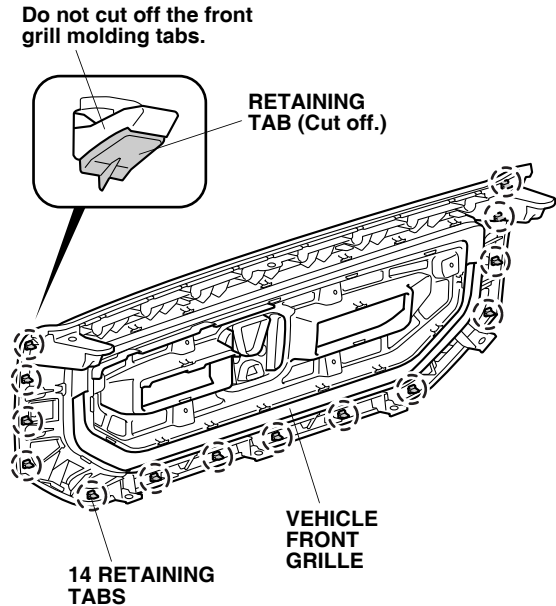

- Cut off sixteen areas on the vehicle front grille as shown. Do not damage the front grille molding tabs when cutting the vehicle front grille.

NOTE: Do not cut off the front grill molding tabs.

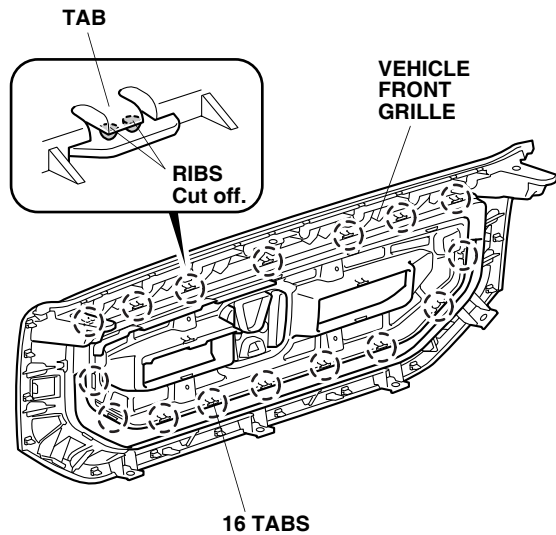

6. Remove the front grille molding from the vehicle front grille by disengaging eight screws.

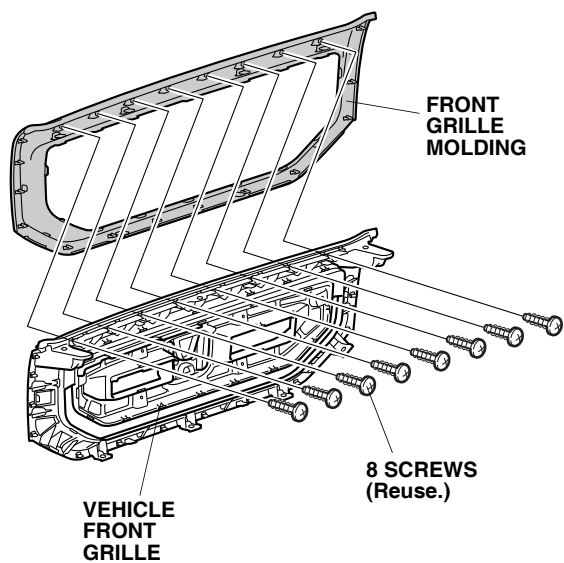

7. Remove the rubber molding from the vehicle front grille.

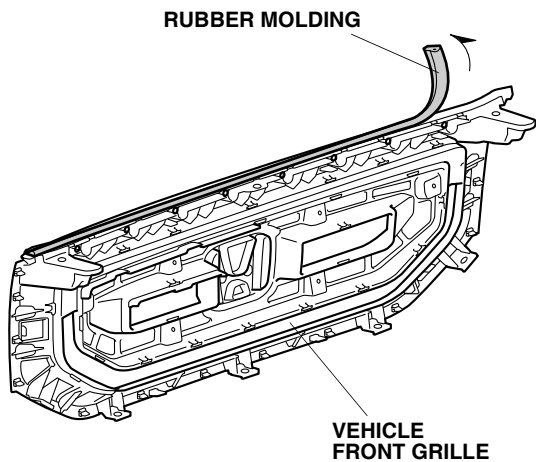

8. Install the rubber molding removed in step 7, to the accessory front grille

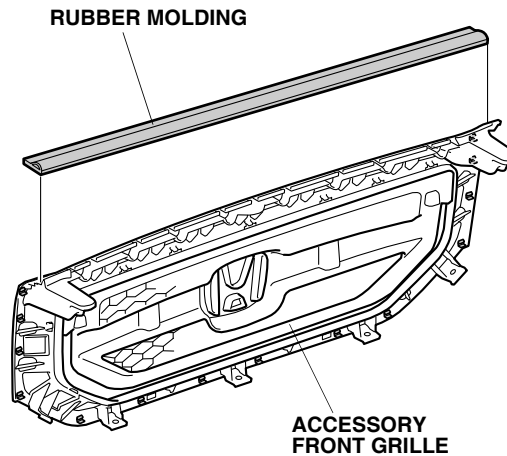

Install the grille molding to the accessory front grille

9. Align the front grille molding to the accessory front grille and install with fourteen retaining tabs and sixteen tabs.

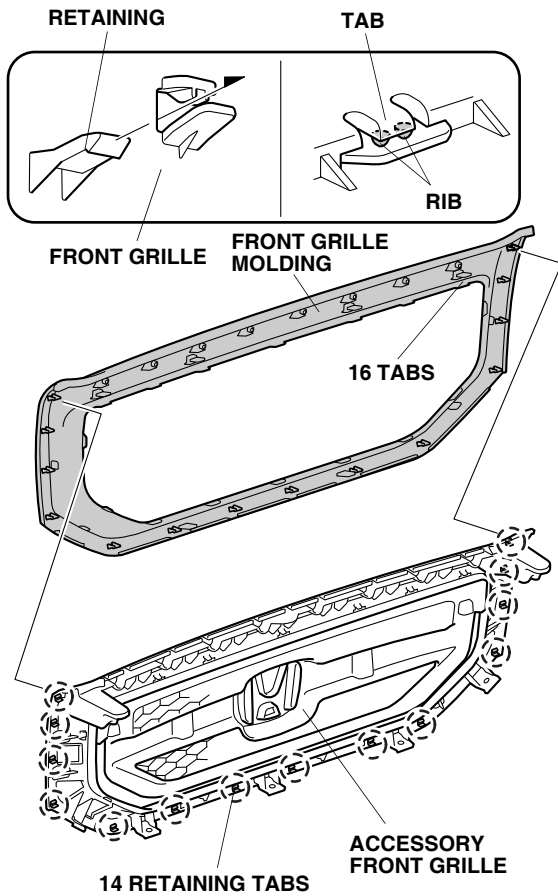

10. Secure the front grille molding to the accessory front grille with eight screws removed in step 6.

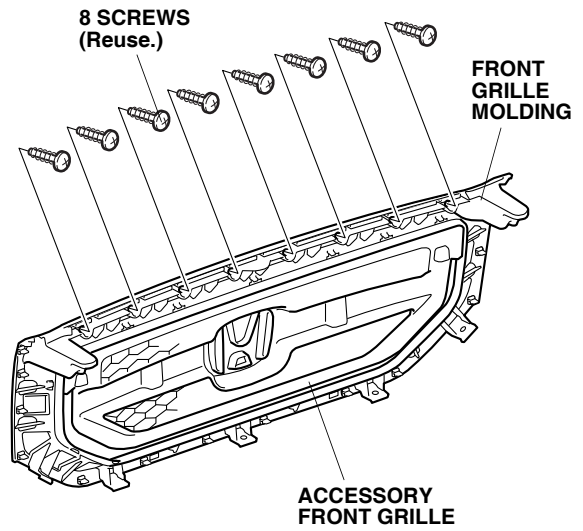

11. Install the accessory front grille to the front bumper with five clips removed in step 3.

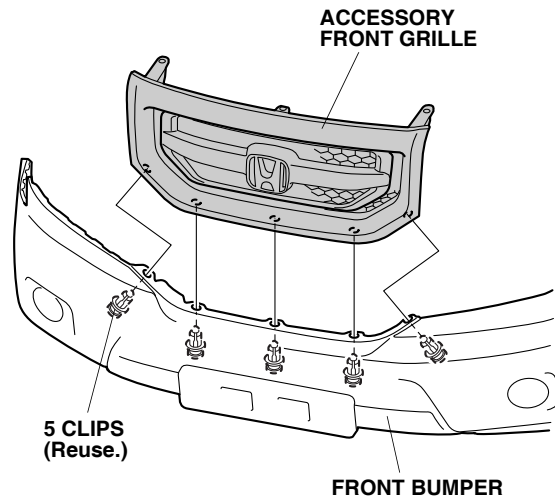

12. Reinstall the front bumper to the vehicle with nine clips, four self-tapping screws and four bolts. Have an assistant help you when installing the front bumper. If the vehicle is equipped with the foglights or the front corner sensors, plug the connectors.

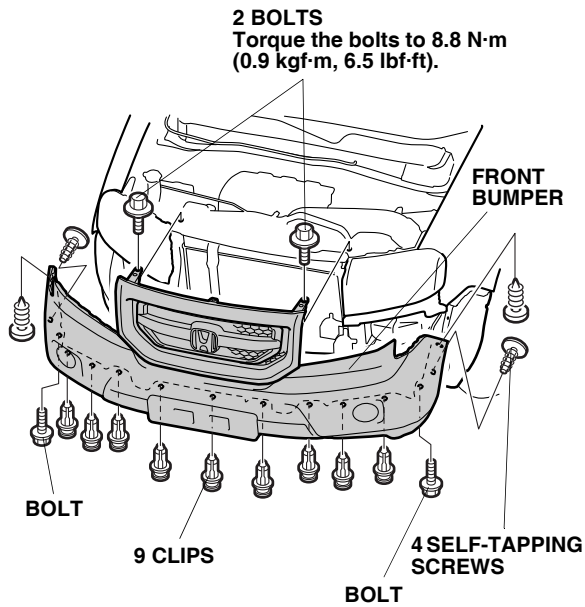

13. Reinstall all removed parts.