

PARTS LIST

HFL Attachment Kit
P/N 08E02-SNA-110 (Beige)
P/N 08E02-SNA-120 (Gray)

HFL trim

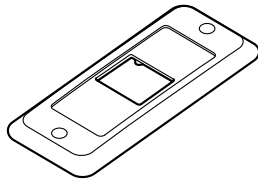

HFL bracket

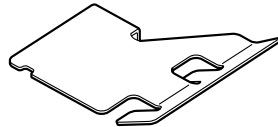

HFL harness

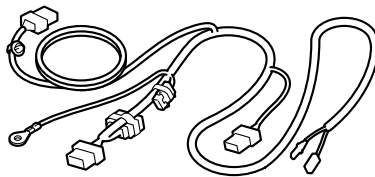

HFL switch bracket

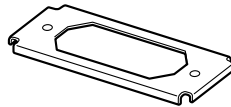

Template

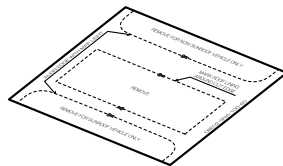

Fuse label

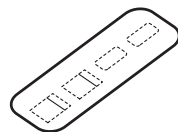

2A Fuse



3 EPT sealers

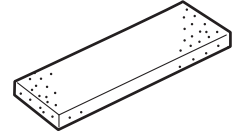

2 Double-sided tapes

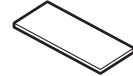

18 Wire ties

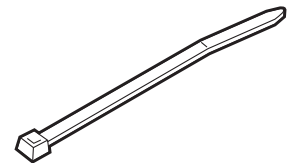

Long wire tie

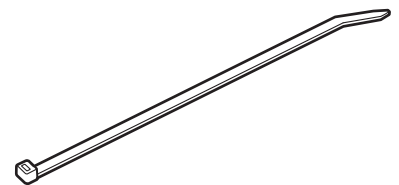

2 Flange bolts, 6 x 12 mm



2 Pan screws, 5 x 12 mm



Clip



3 Foam blocks

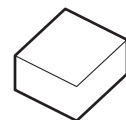

**HFL Kit
P/N 08E00-E10-100**

Switch

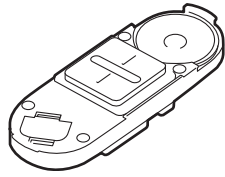

Control unit

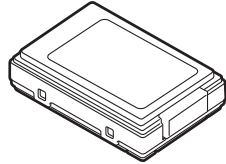

Accessory User's Information Manual

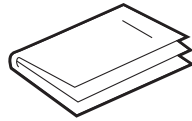

TOOLS AND SUPPLIES REQUIRED

- Phillips screwdriver
- Small flat-tip screwdriver
- Flat-tip screwdriver
- Shop towel
- Isopropyl alcohol
- Diagonal cutters
- Ratchet
- 10 mm and 12 mm Sockets
- 10 mm Wrench
- Utility Knife
- T-25 Torx wrench
- Felt-tip pen
- Masking tape
- Plastic trim tool
- T/N SILTRIMTL 10
- Scissors
- Eye protection (face shield, safety goggle, etc.)
- Rubber mallet
- Needle nose pliers
- Scale

Illustration of the HFL Installed on the Vehicle

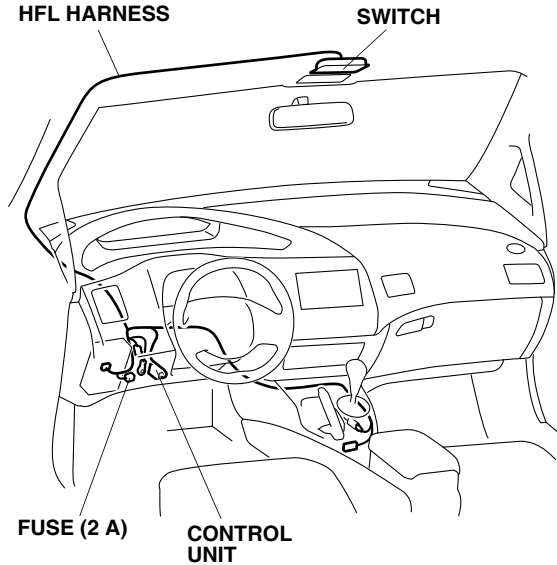

INSTALLATION

Customer Information: The information in this installation instruction is intended for use only by skilled technicians who have the proper tools, equipment, and training to correctly and safely add equipment to your vehicle. These procedures should not be attempted by "do-it-yourselfers."

1. Make sure you have the anti-theft code for the audio unit and the navigation system, then write down the radio presets.
2. Disconnect the negative cable from the battery.

Before Installation

- Using scissors, cut out the appropriate template as shown.

WITH SUNROOF

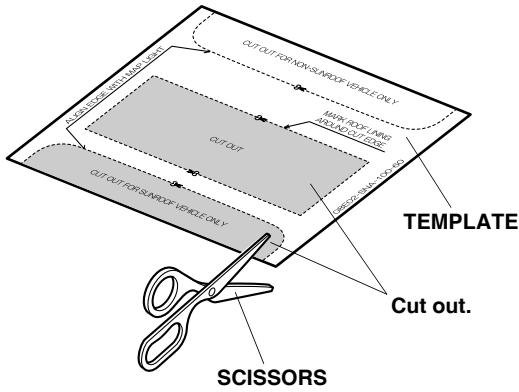

WITHOUT SUNROOF

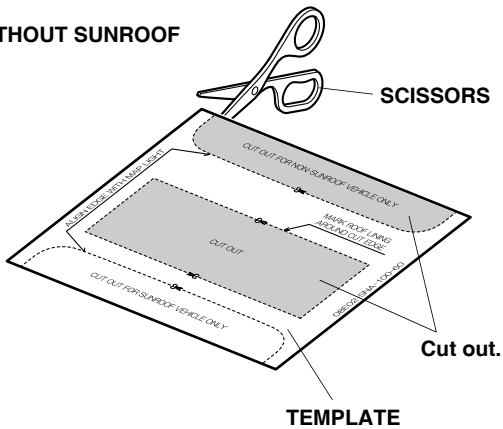

If the vehicle is equipped with map light, continue with step 4; otherwise, go to step 5.

- Align the template to the headliner and tape it in place with masking tape. Go to step 6.

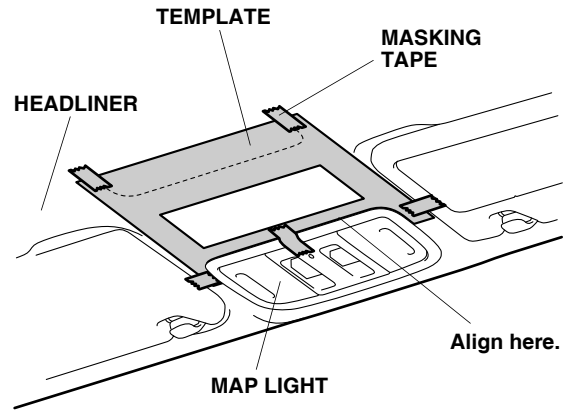

- Measure 145 mm from the front edge of the headliner and align the template to the headliner as shown. Tape the template to the headliner with masking tape.

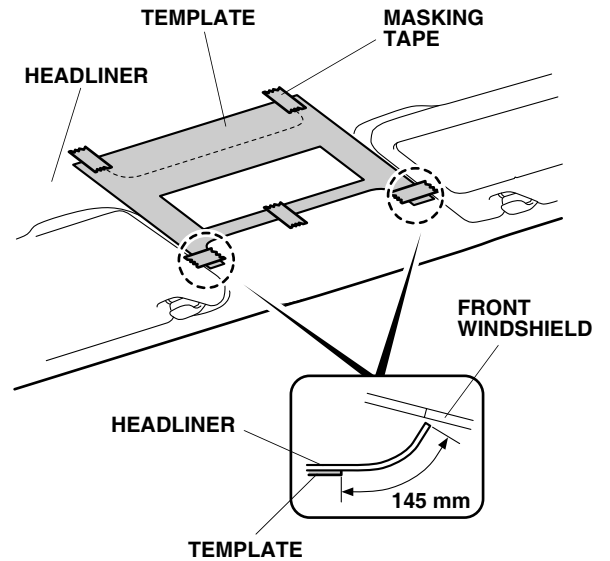

- Using a felt-tip pen, mark the headliner along the template as shown. Remove the template.

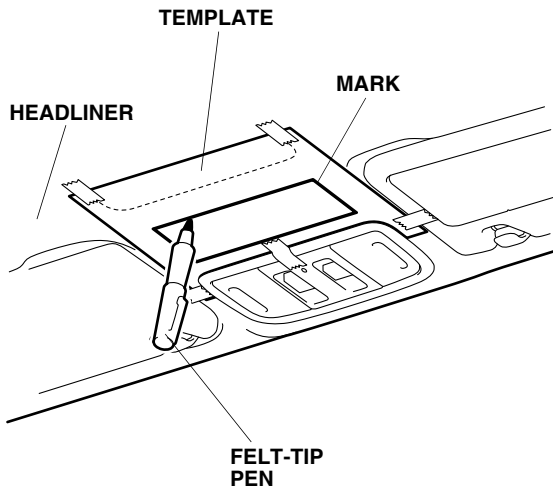

If the vehicle is equipped with map light, continue with step 7; otherwise, go to step 8.

- Using a plastic trim tool, remove the left and right lens from the map light console (four retaining tabs for each lens). Remove the map light console (two bolts and unplug the vehicle connector).

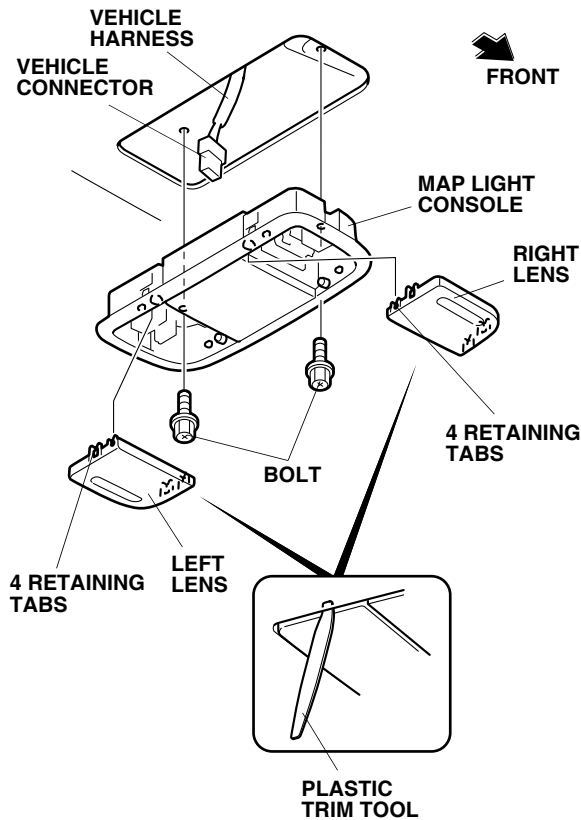

- Remove the right and left sunvisor holders. Using a small flat-tip screwdriver, push the hook, and turn the holder, to remove.

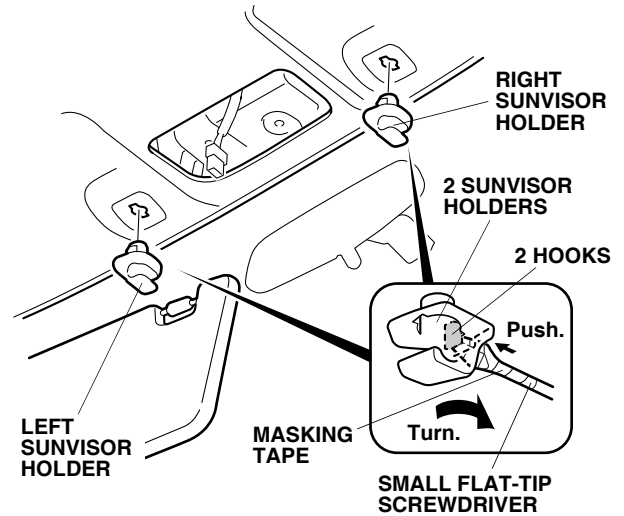

- Remove the cover from the left sunvisor (four retaining tabs). Remove the left sunvisor (two T-25 Torx screws, and unplug the vehicle connectors, if equipped).

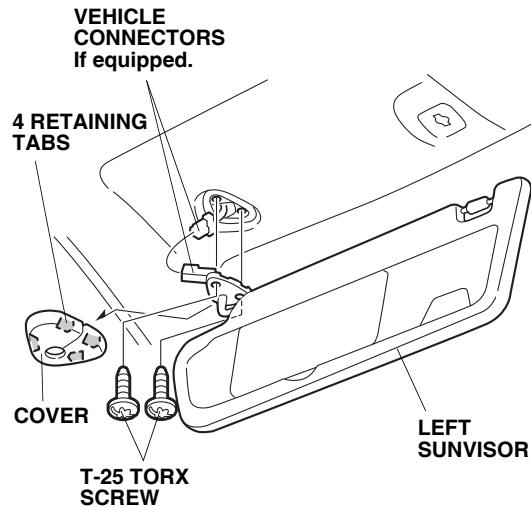

10. Pull down the left grab rail and remove the two caps (four retaining tabs).

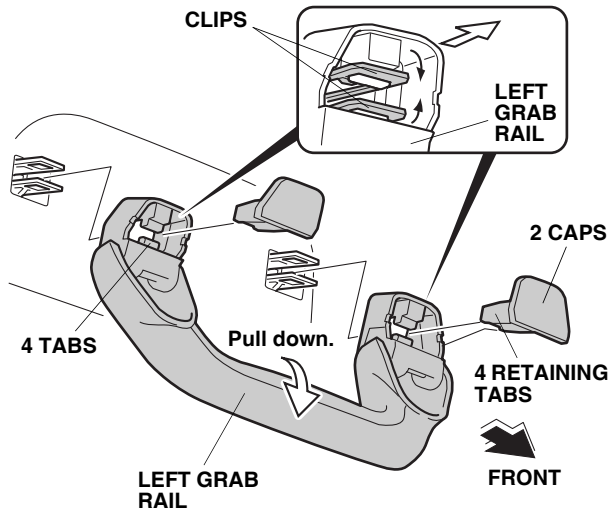

11. Using a flat-tip screwdriver wrapped with masking tape, remove the left grab rail (four tabs).
12. Remove the tape securing the map light harness, and move the harness out of the way before cutting the headliner.

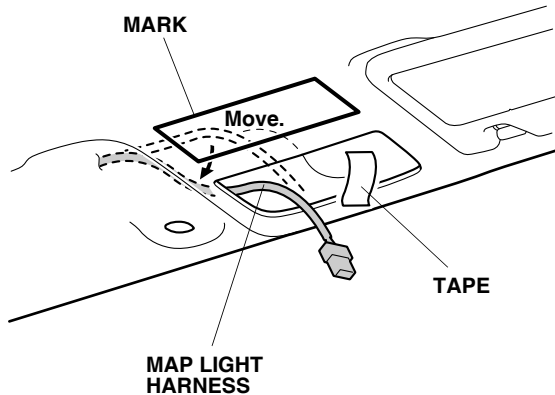

13. Using an utility knife, cut out the headliner at the mark made in step 6.
NOTE: Check the position of the map light harness again before cutting.

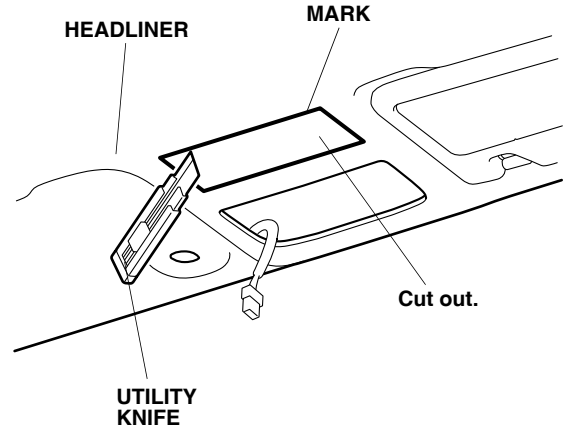

14. Pull away the weatherstrip from the left A-pillar trim.

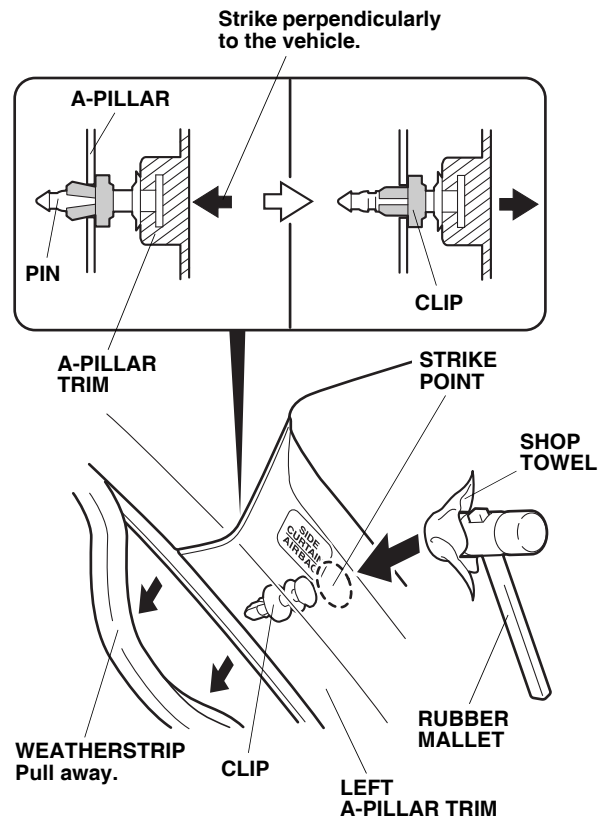

15. Using a rubber mallet and a shop towel, lightly tap the left A-pillar trim just below the "SIDE CURTAIN AIRBAG" mark to release the clip.

16. Pull away the weatherstrip from the left A-pillar trim, and remove the left A-pillar trim (two clips).

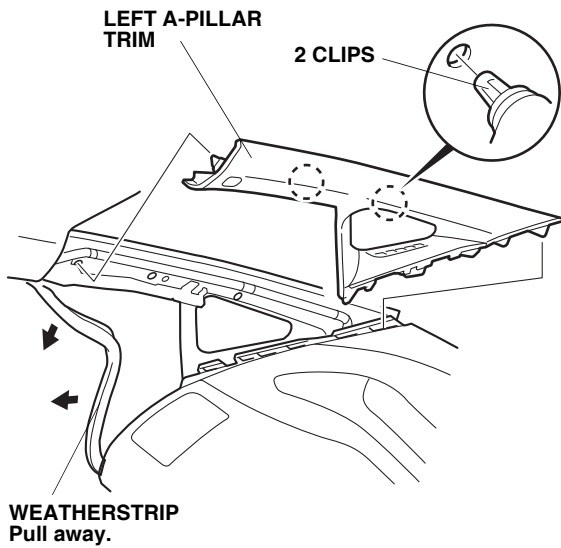

17. Discard the old clip from the left A-pillar trim, and install a new clip on the left A-pillar trim.

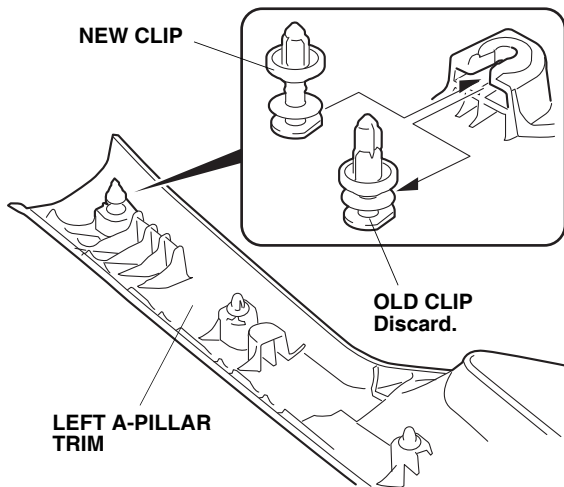

18. Remove the center console cover.

M/T Vehicle:

- Push down on the shift boot. Remove the shift knob by turning it counterclockwise.

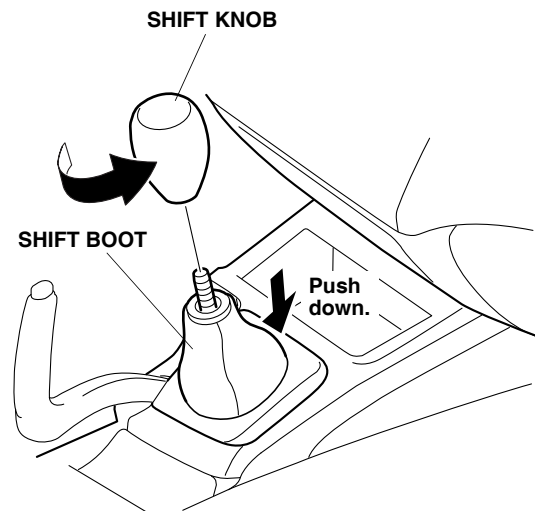

- Remove the center console cover (five clips).

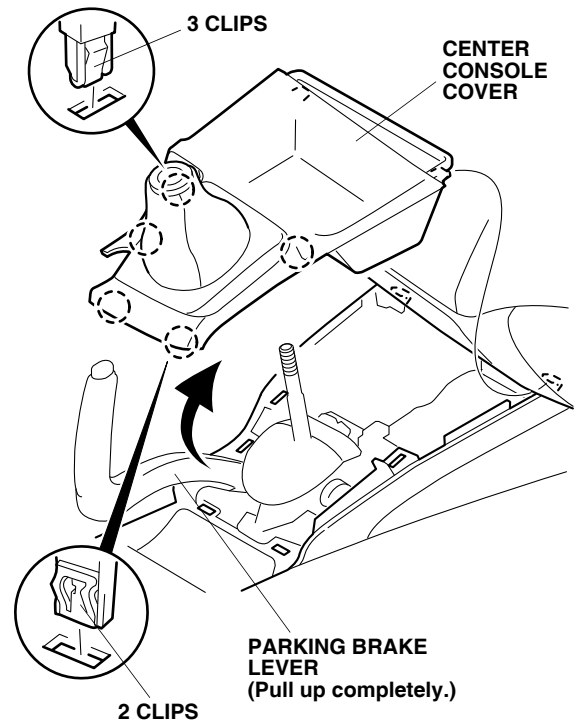

A/T Vehicle:

Move the select lever to the "N" position. Remove the center console cover (five clips).

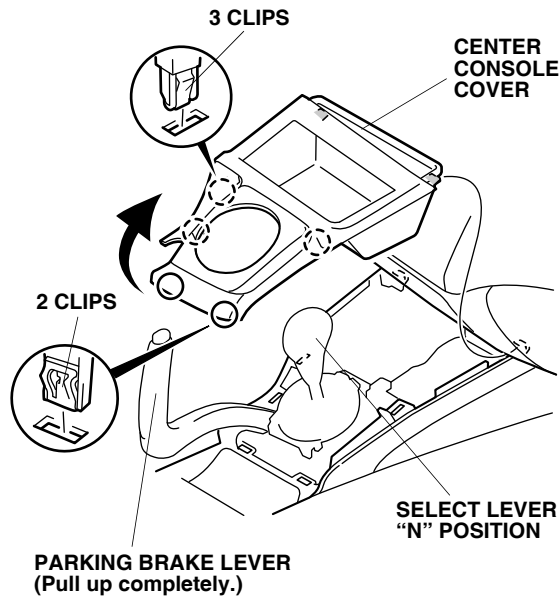

19. Open the center console lid, and remove the mat.

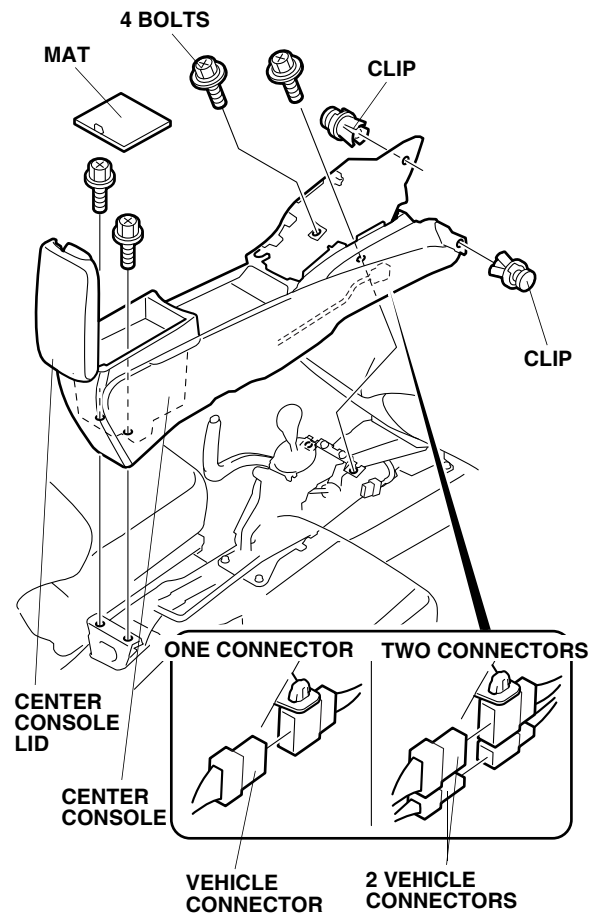

20. Remove the center console (four bolts, two clips, and unplug one vehicle connector or two vehicle connectors).

21. If equipped, remove the driver's under cover (turn the knob counterclockwise, two clips and one pin).

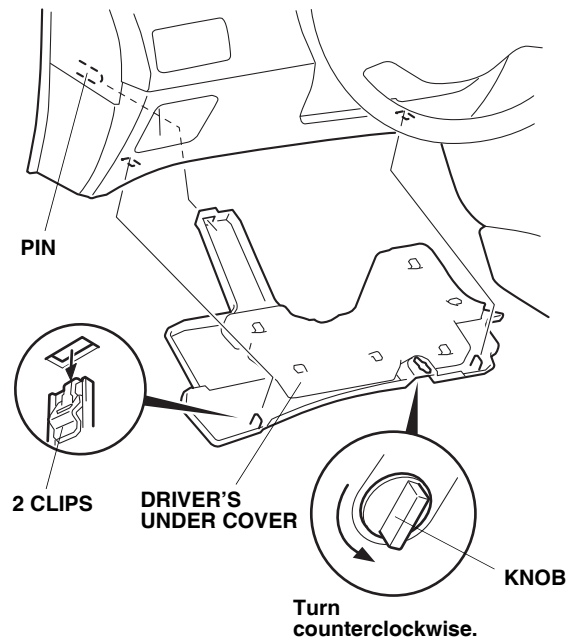

22. Remove the driver's lower cover (eight clips).

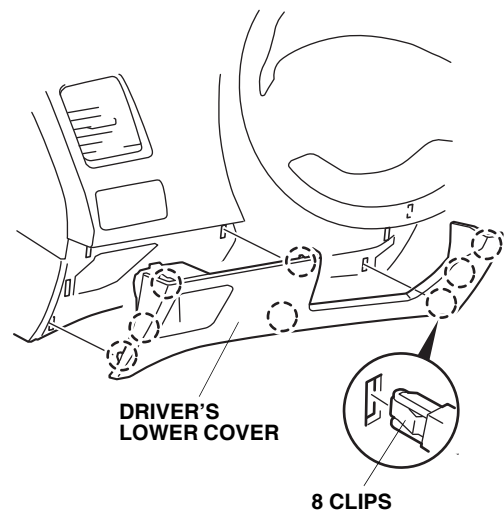

Routing the HFL Harness

23. Get the HFL harness. Attach one 2A fuse label to the HFL harness fuse case.

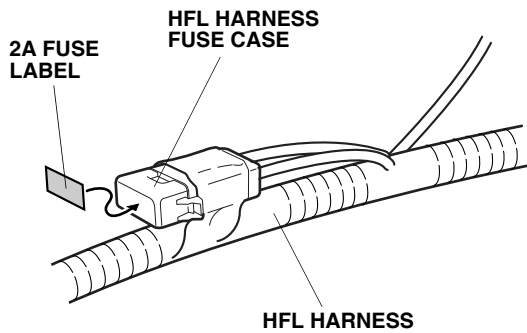

24. Plug the HFL harness 6-pin connector into the fuse box 6-pin connector.

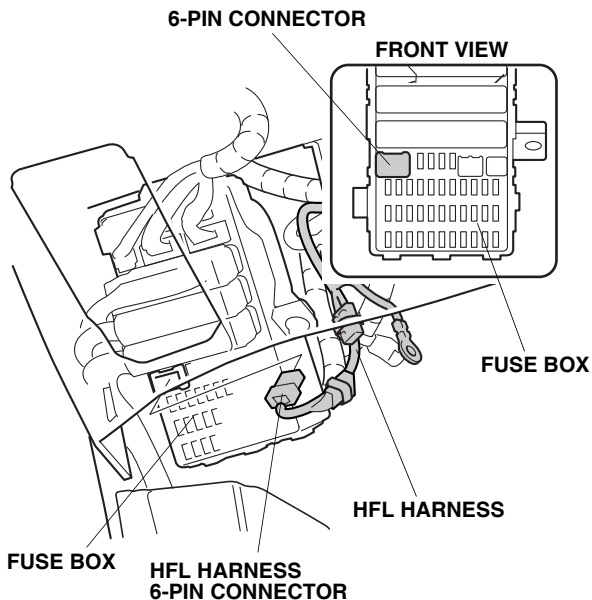

If another harness is already plugged to the fuse box, unplug it. Remove the dummy connector from the HFL harness 6-pin connector taped to the HFL harness, and plug the other accessory 6-pin connector into the HFL harness. Plug the HFL 6-pin connector into the fuse box.

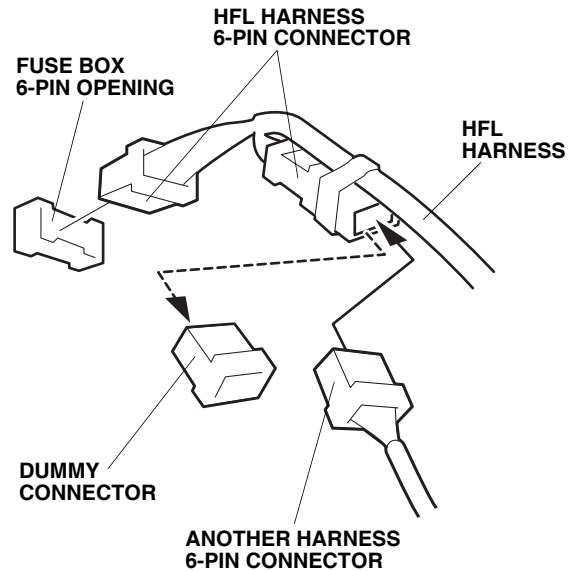

25. Route the HFL harness white 20-pin connector from driver's under cover opening to the left A-pillar trim opening.

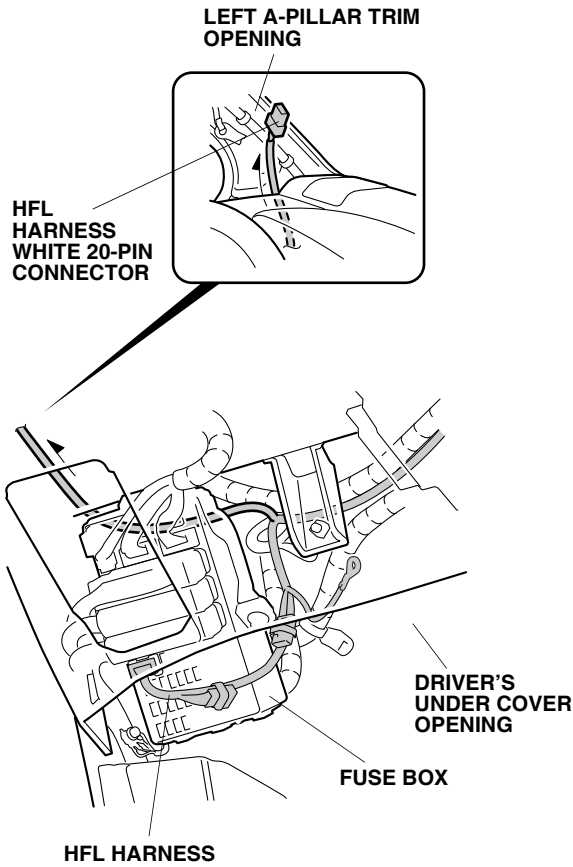

26. Route the HFL harness up the A-pillar along side the vehicle harness.

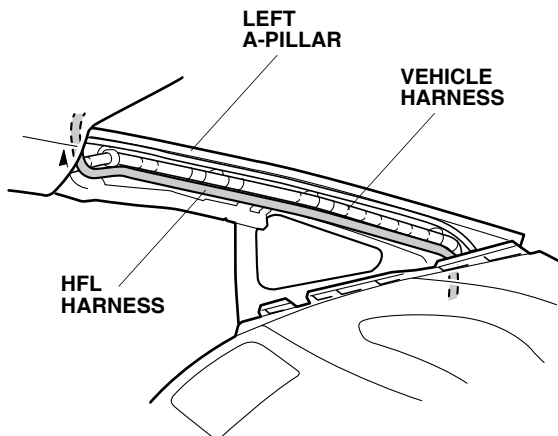

27. Loosely secure the HFL harness to the vehicle harness with four wire ties. If the vehicle is equipped with the washer tube, do not secure the wire ties around the washer tube.

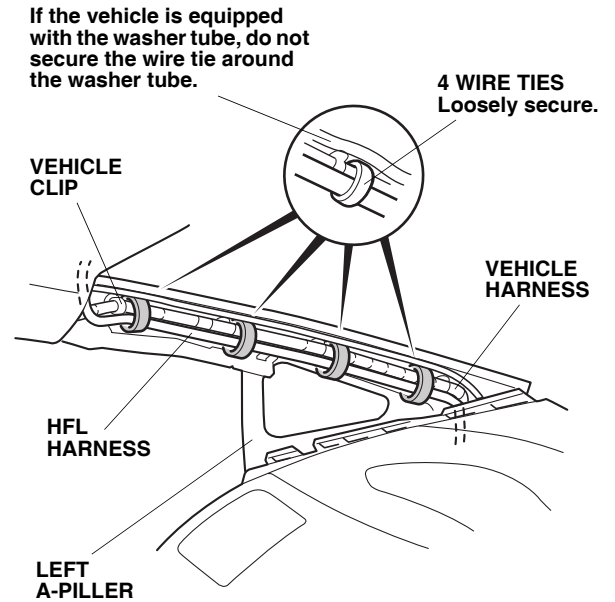

28. Using scissors, cut one EPT sealer in half. Wrap the two pieces of EPT sealer around the HFL harness at the measurements shown.

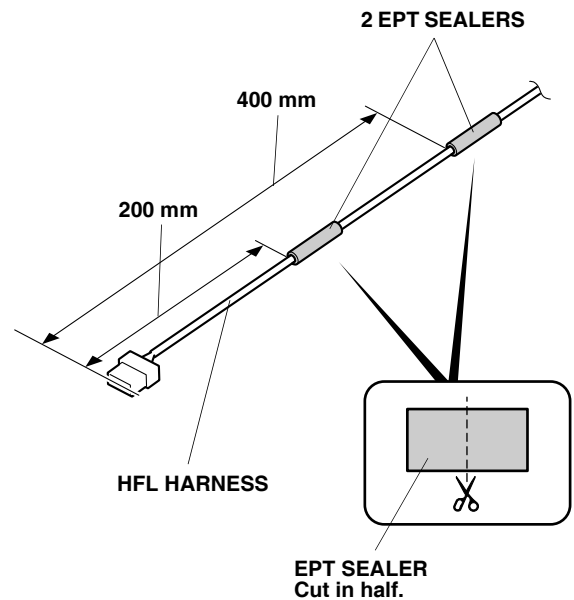

29. Route the HFL harness to the opening in the headliner, and leave 80 mm of the HFL harness extending from the opening.

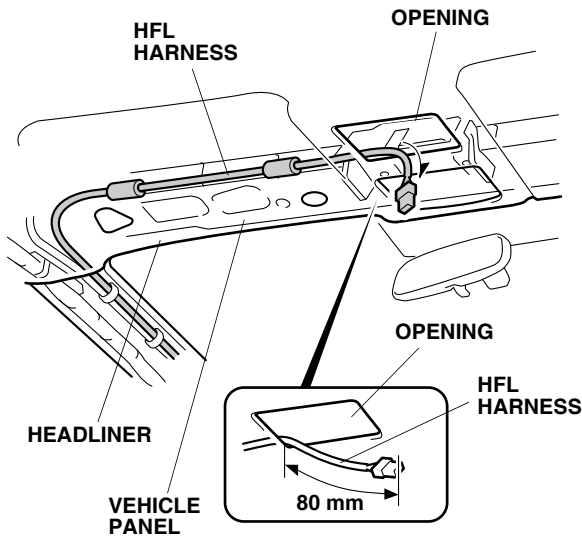

30. Tighten the four wire ties you installed in step 27.
 31. Route the HFL harness in the direction shown.

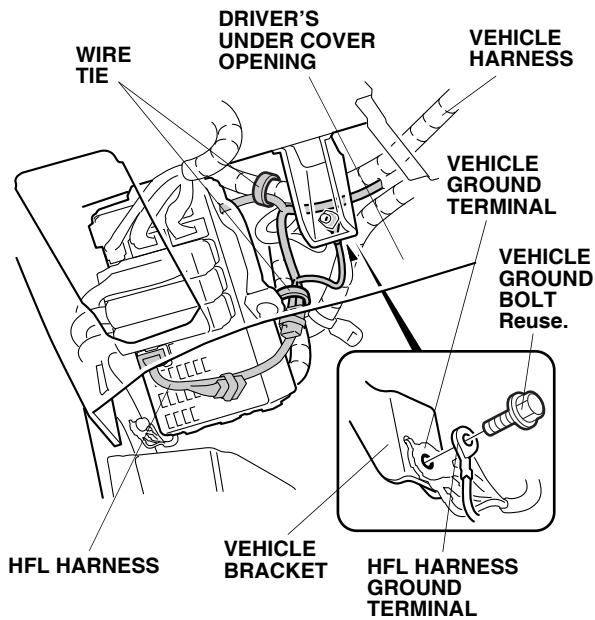

32. Remove the vehicle ground bolt. Attach the HFL harness ground terminal, and reinstall the ground bolt.
 33. Secure the HFL harness to the vehicle harness with two wire ties.

34. Route the HFL harness along the vehicle harness as shown.

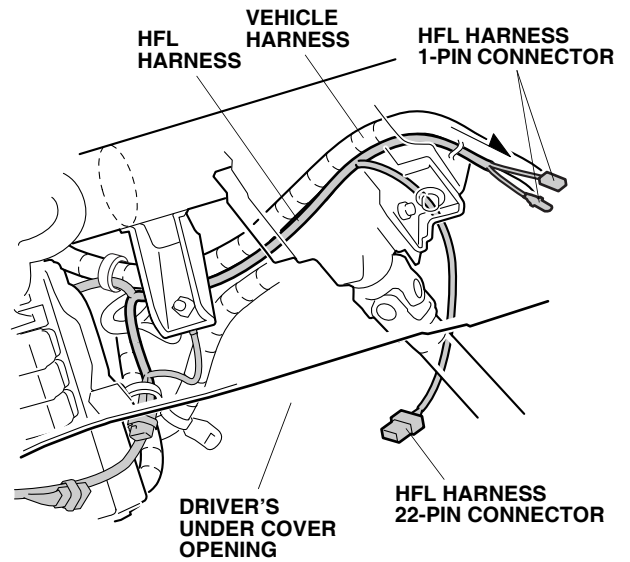

35. Secure the HFL harness to the vehicle harness with two wire ties.

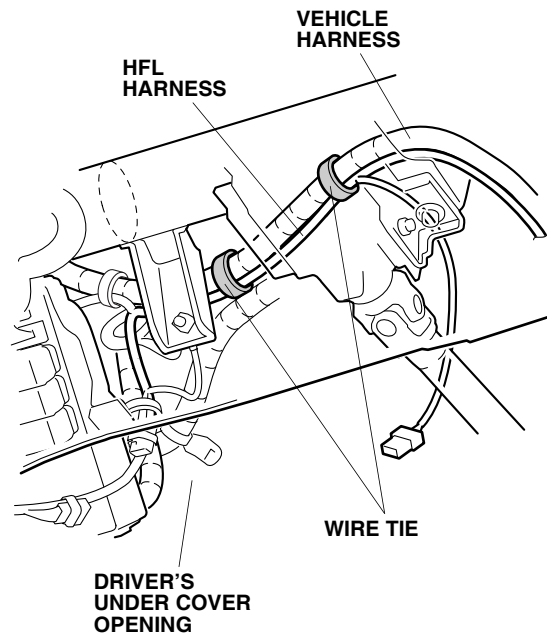

36. Route the HFL harness towards the center console as shown.

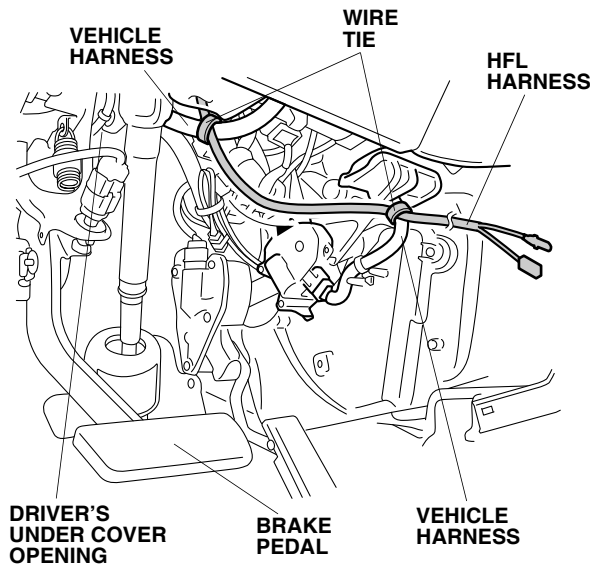

37. Secure the HFL harness to the vehicle harness with two wire ties.
38. Route the HFL harness through the center console area as shown.

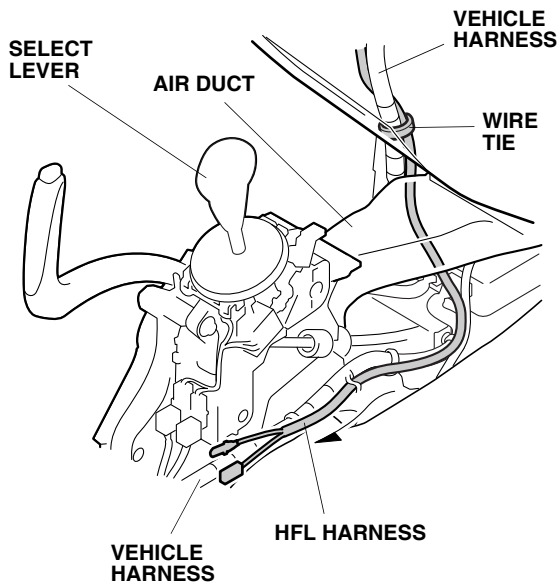

39. Secure the HFL harness to the vehicle harness with one wire tie.

40. Unplug the parking brake switch 1-pin connector and plug it into HFL harness 1-pin connector. Plug the HFL harness into the parking brake switch.

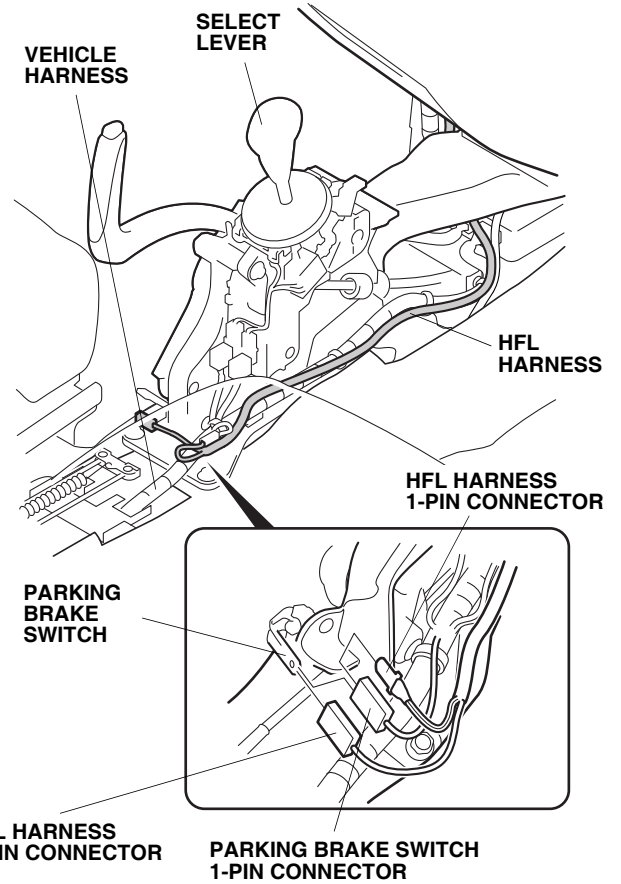

41. Secure the HFL harness to the vehicle harness with three wire ties. Do not secure the wire ties to the SRS harness.

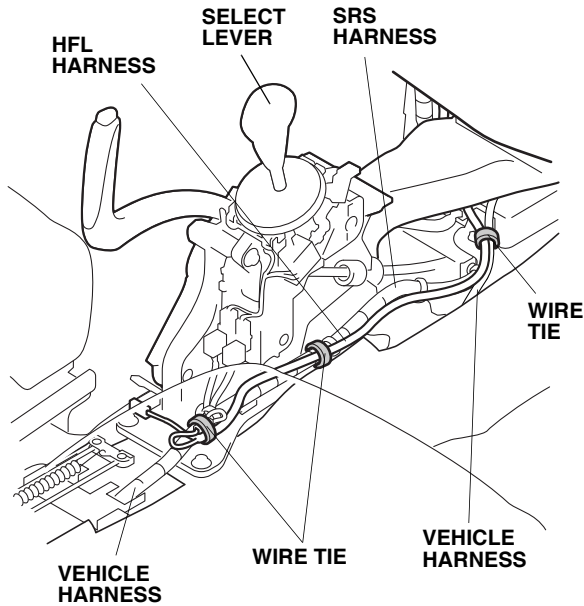

Installing the Switch

42. Install the switch to the HFL trim with two hooks and four pins. Make sure the speaker and the microphone are in correct orientation with the HFL trim.

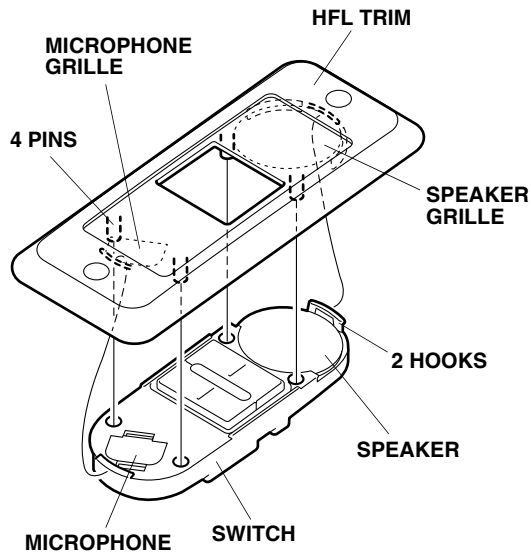

If the vehicle is equipped with a sunroof, continue with 43; otherwise, go to step 46.

43. Attach two EPT sealers to sunroof frame in the area shown.

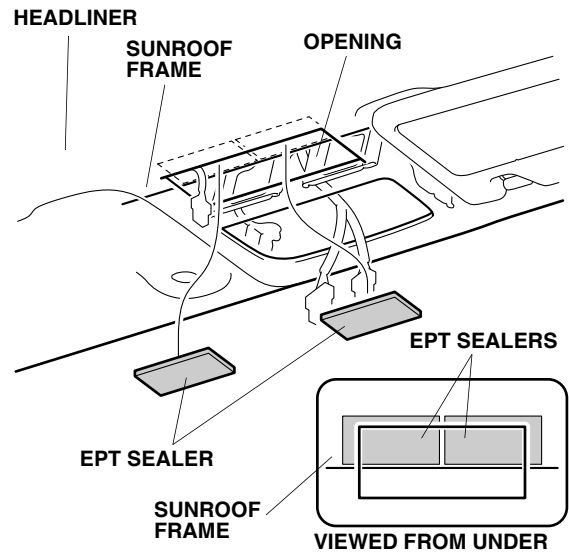

44. Insert the HFL switch bracket inside the headliner through the opening made in step 13.

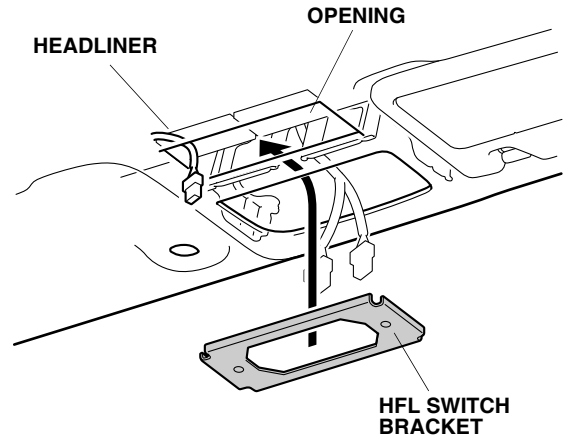

45. Route the HFL harness out the headliner opening, and plug the white 20-pin connector into the switch. Secure the switch to the HFL bracket with two 5 x 12 mm pan screws. Go to step 49.

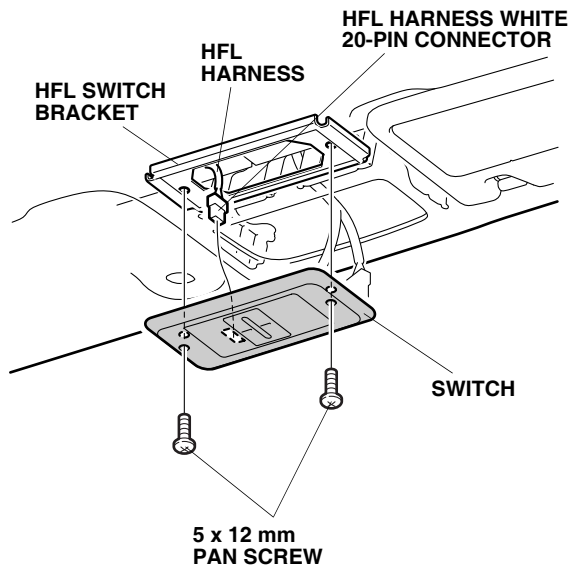

46. Using an isopropyl alcohol on a shop towel, clean the area where the foam blocks will attach. Remove the adhesive backing from each of the foam blocks, and attach the foam blocks to the switch as shown.

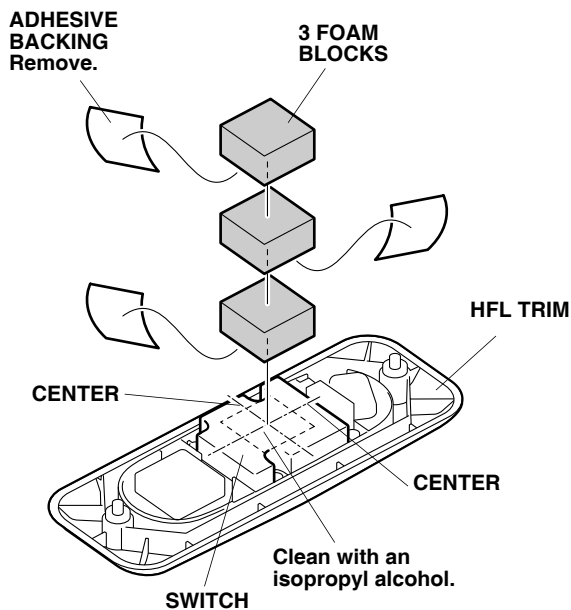

47. Insert the HFL switch bracket inside the headliner through the opening made in step 13.

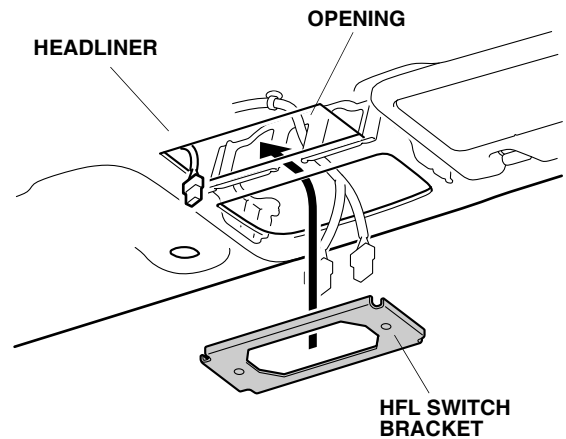

48. Route the HFL harness out the headliner opening, and plug the white 20-pin connector into the switch. Secure the switch to the HFL bracket with two 5 x 12 mm pan screws.

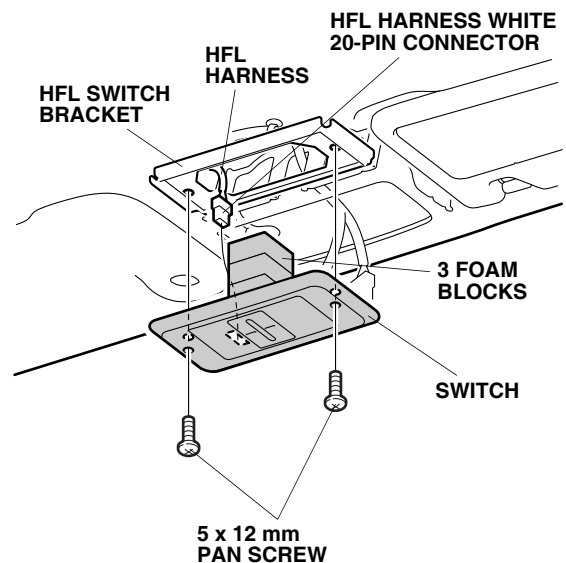

Installing the Control Unit

49. Using an isopropyl alcohol on a shop towel, thoroughly clean the control unit, (opposite the label) where the double-sided tape will attach.

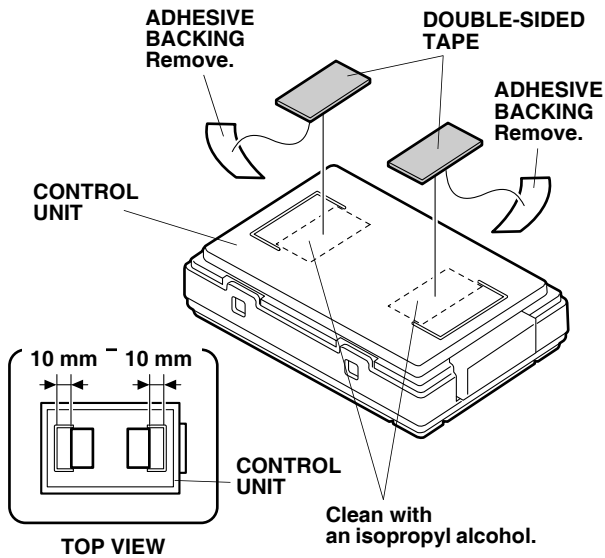

50. Remove the adhesive backings from each double-sided tape and attach the tape to the control unit as shown.

51. Using an isopropyl alcohol on a shop towel, thoroughly clean the HFL bracket area where the double-sided tape will attach.

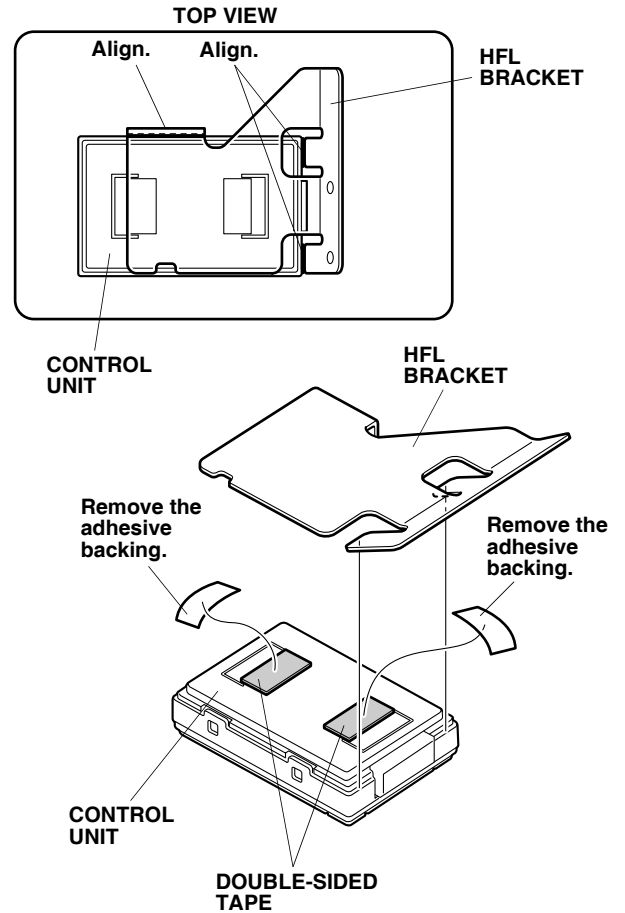

52. Remove two adhesive backings from the control unit and attach the HFL bracket to the control unit.

53. Secure the control unit to the HFL bracket with one long wire tie at the indent and through the hole as shown.

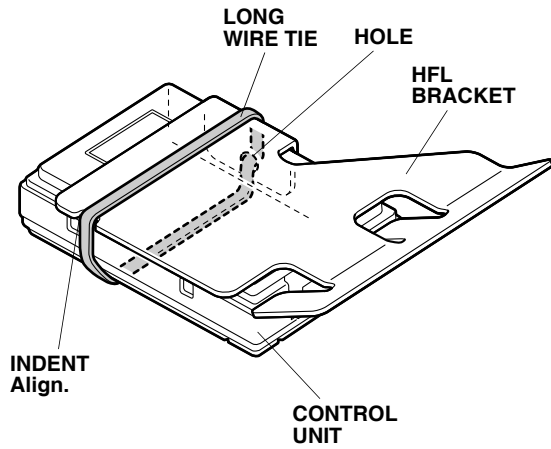

54. Plug the HFL harness 22-pin connector to the control unit.

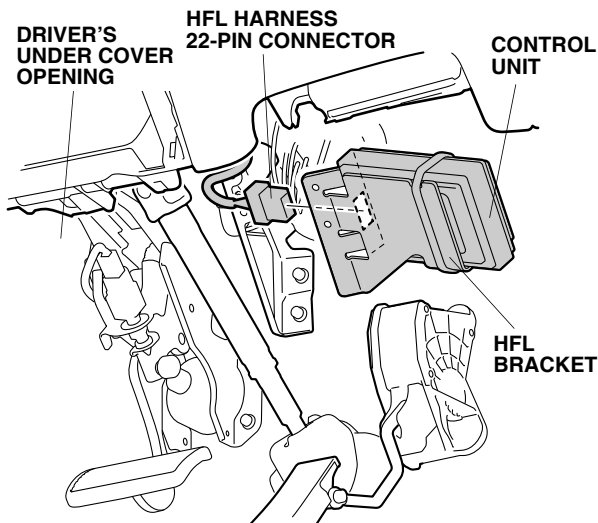

55. Secure the HFL bracket to the vehicle bracket with two 6 x 12 mm flange bolts.

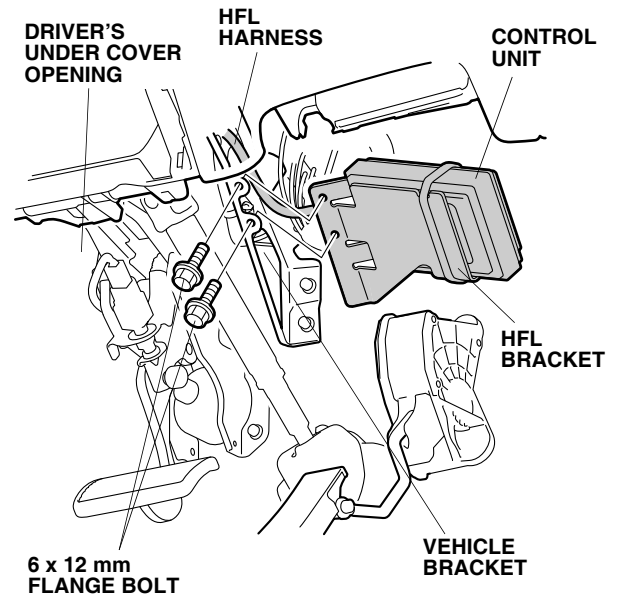

56. Install the 2A fuse to the No. 27 slot on the fuse box.

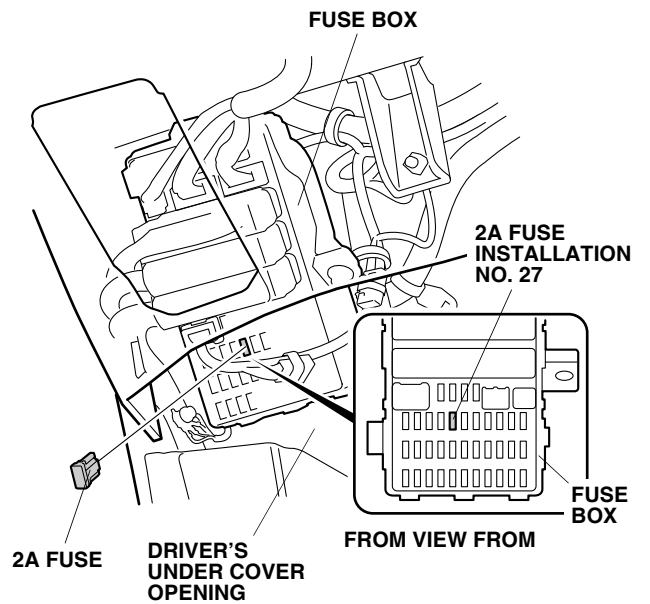

57. Attach the 2A fuse label to No. 27 slot on the left kick panel.

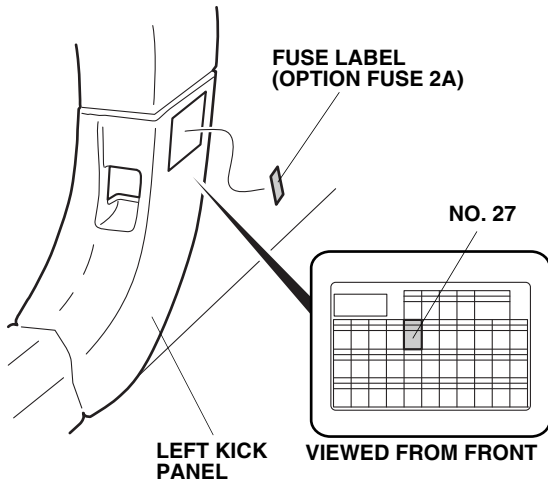

58. Using needle nose pliers, remove two clips from the vehicle panel.

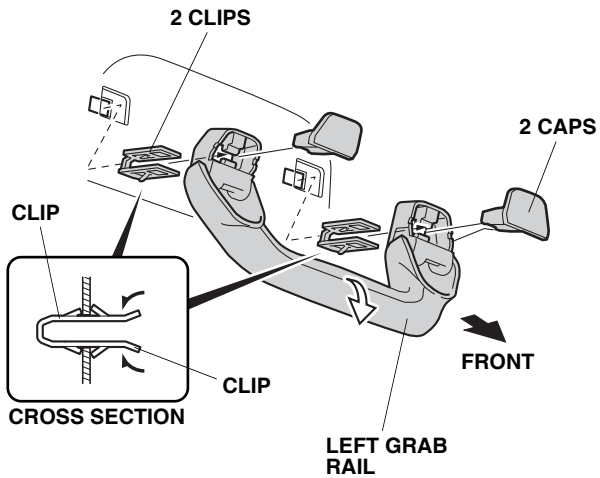

59. Reinstall the left grab rail with two clips and two caps.

60. Check that all wire harness are routed properly and all connectors are plugged in.
61. Reinstall all removed parts.
62. Connect the negative cable to the battery.
63. Enter the anti-theft codes for the audio system and the navigation system (if equipped), and reset the radio station presets.
64. Reset the clock on vehicles without navigation.