



# INSTALLATION INSTRUCTIONS

Accessory

KAYAK ATTACHMENT  
P/N 08L09-TA1-100

Application

2010 CR-V

Publications No.

All 42609

Issue Date

SEPT 2009

Put this information in the glove box with the vehicle owner's manual.

## PARTS LIST

2 Saddles

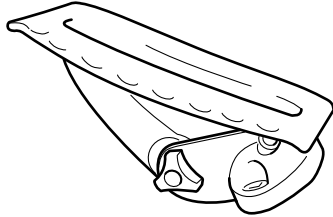

2 Hydro-glide assemblies

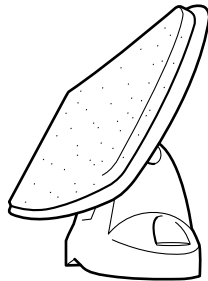

4 Brackets

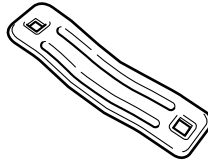

8 Bolts

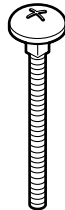

8 Knobs



2 Straps with buckle

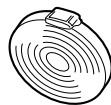

2 Buckle covers

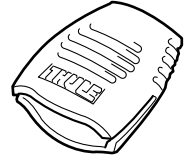

2 Attachment straps



2 Ratchet hooks



2 Hooks

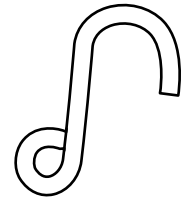

2 Pieces of rope

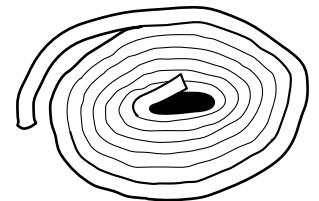

## INSTALLATION

NOTE: Be careful not to damage the finished surfaces of the body when installing the kayak attachment.

1. Position the two saddles on the front crossbar, and loosely install the saddles using one bracket, two bolts, and two knobs for each saddle. The distance between the two assemblies should be the same width as the kayak.

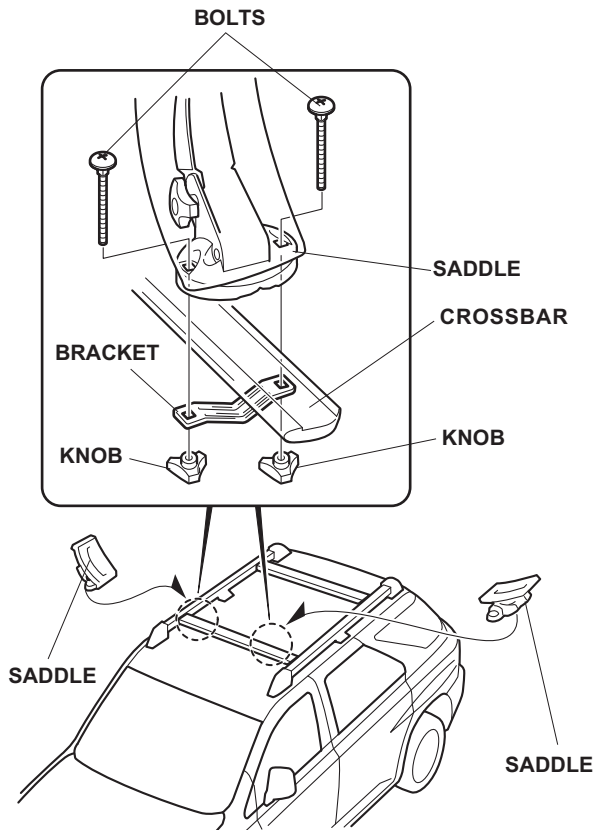

2. Position the two hydro-glide assemblies on the rear crossbar, and loosely install the hydro-glide assemblies using one bracket, two bolts, and two knobs for each assembly. The distance between the two assemblies should be the same width as the kayak.

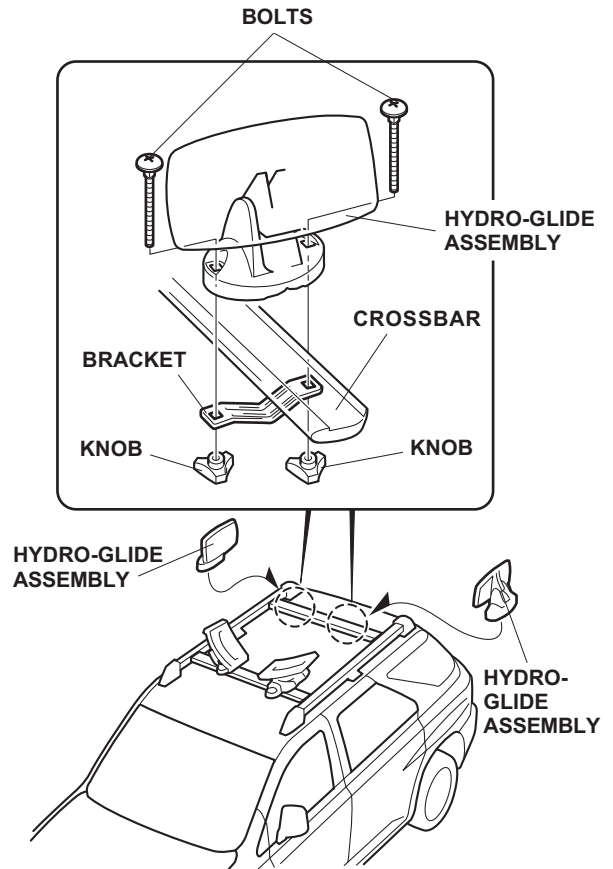

- Rest the front of the kayak on the hydro-glide assemblies. Standing behind or alongside the kayak, lift up the rear-end portion of the kayak, and push it forward, sliding it on the hydro-glide assemblies and saddles. Make sure the kayak reaches the front saddles before you lower it.

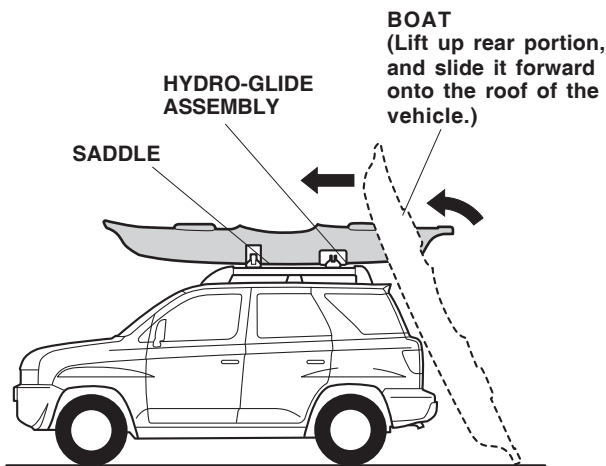

- Adjust the distance of the saddles and hydro-glide assemblies to the same width as the kayak, then secure the saddle and the hydro-glide assemblies by tightening the knobs you installed in steps 1 and 2.

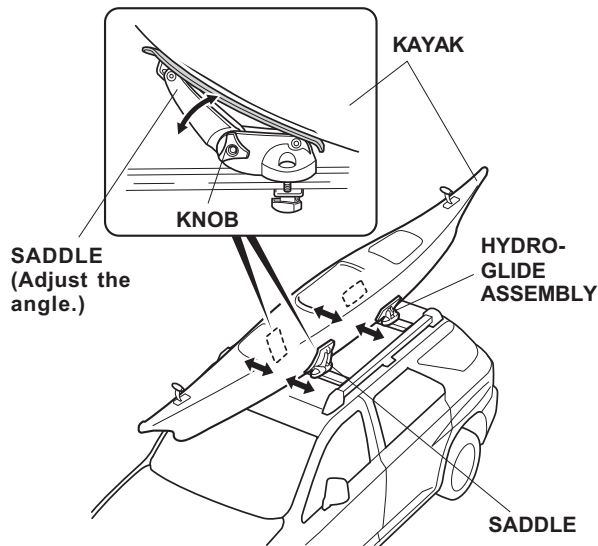

- Slide the kayak forward or backward until it's level with the roof. If necessary, loosen the knob of each saddle and adjust the saddle angle to fit snugly against the kayak. Tighten each knob securely.

- Route each strap with buckle through the buckle cover with the ribbed side facing up.

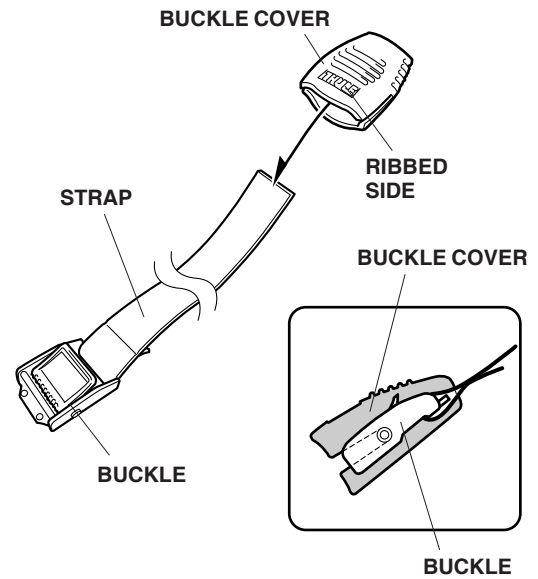

- Route the straps from the buckle under the front crossbars and around the kayak as shown. Slide the buckle cover away from the buckle, route the straps through the buckles, and tighten the strap. Slide the buckle cover back over the buckle.

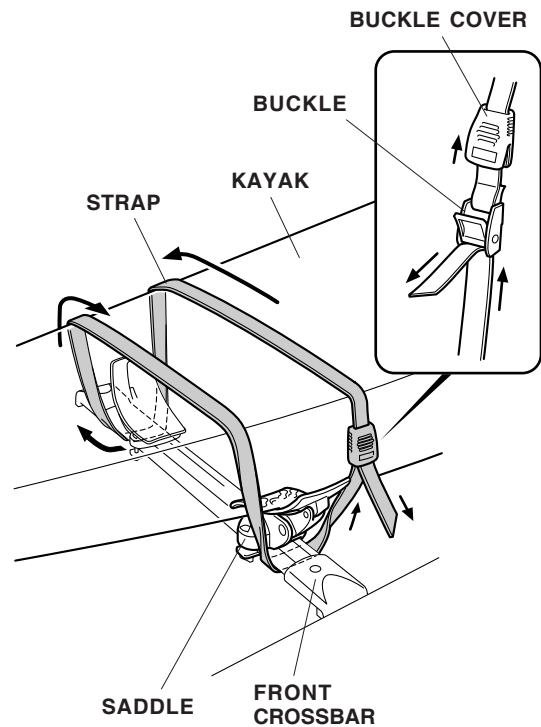

- Route the straps from the buckle under the rear crossbars and around the kayak as shown. Slide the buckle cover away from the buckle, route the straps through the buckles, and tighten the strap. Slide the buckle cover back over the buckle.

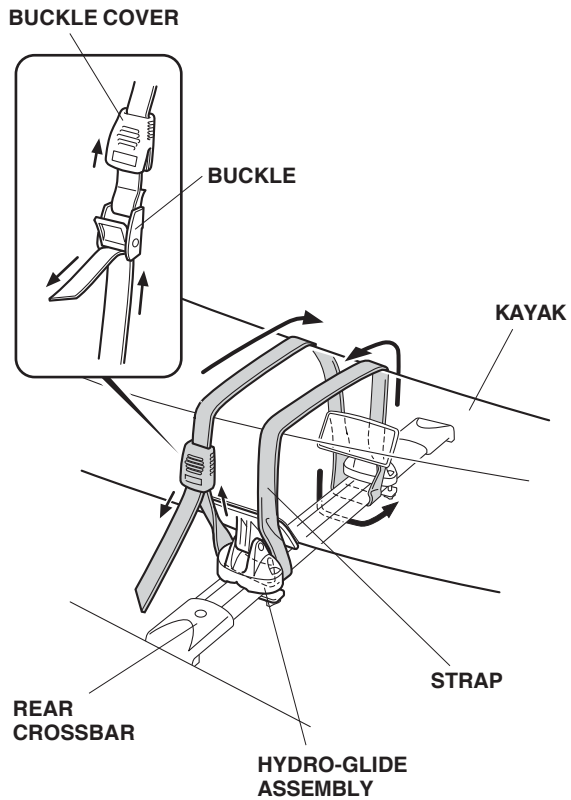

- Attach the rope to the end of the hook. Tie a knot in the rope to secure the rope to the hook.

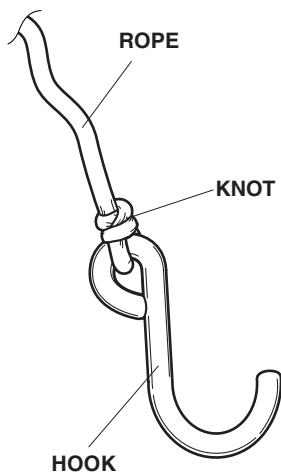

- Route the other end of each rope through the bottom of a ratchet in the direction shown, and turn the spool until the rope end comes out of the ratchet.

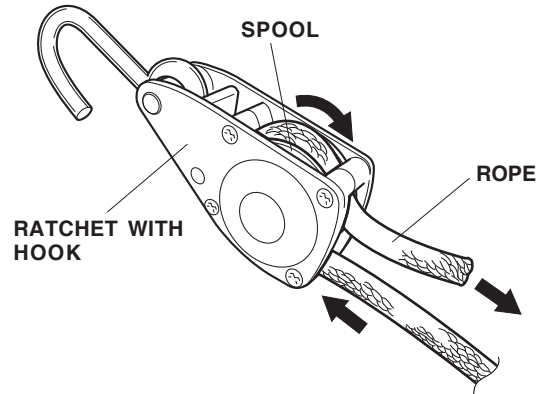

- Wrap one attachment strap around the handle at the front and rear of the kayak.

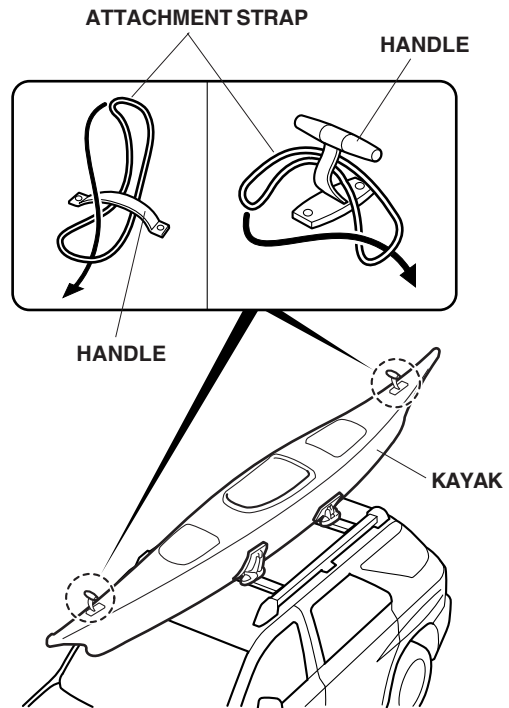

12. Attach one ratchet hook to the front attachment strap and one ratchet hook to the rear attachment strap. Hook the other end of the ratchet strap to the front bumper beam or to the tow hook. Hook the other end of the rear ratchet strap to the rear bumper beam, vehicle body, or tow hook. Secure the kayak to the vehicle by pulling the rope through the ratchet hooks.

- Make sure the hook or rope does not rub against the finished surfaces of the vehicle. Reposition the kayak or use a soft cloth or rag to protect the vehicle's paint.
- Do not attach the hook to plastic parts of the vehicle.

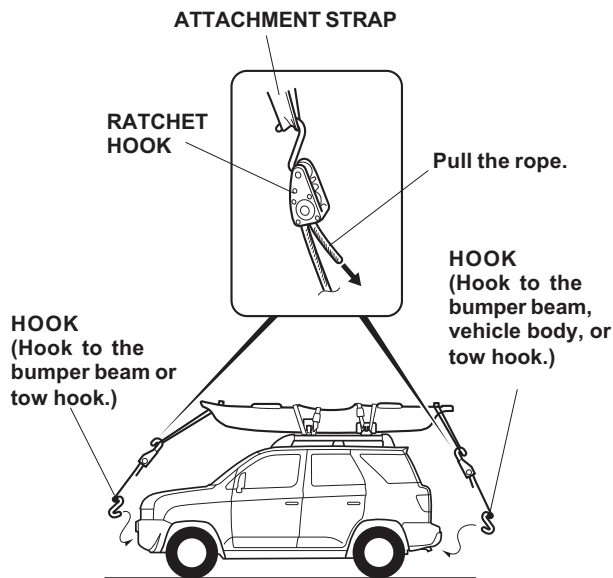

13. To loosen the rope, push up on the ratchet release lever, then pull on the other end of the rope.

