

**INSTALLATION  
INSTRUCTIONS**

Accessory

**XM® SATELLITE RADIO**

Application

**2009 S2000**

Publications No.

**All 40454**

Issue Date

**AUG 2008****PARTS LIST****XM Radio Unit Kit (sold separately):  
P/N 08A53-S2A-101**

XM Radio unit

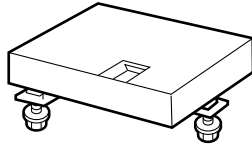
**XM Radio Antenna Kit (sold separately):  
P/N 08A53-S2A-100A**

XM Radio antenna

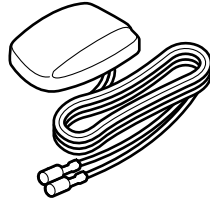

2-pin Connector

**XM Radio Attachment (sold separately):  
P/N 08B15-S2A-100**

XM Radio bracket

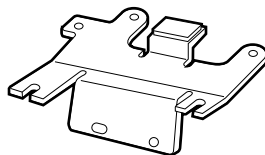

XM Radio bracket template

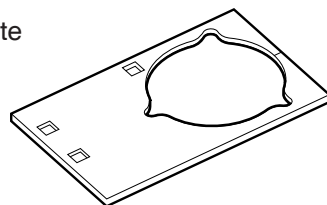

## Template

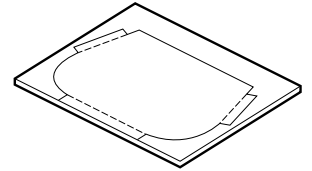

10 Wire ties

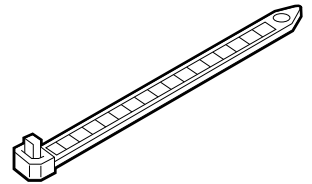

2 Wire ties with clip

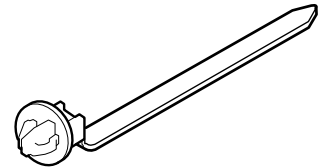

5 EPT sealers

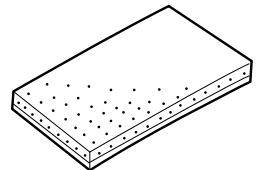

4 Washer-bolts, 6 x 10 mm

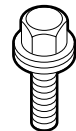

Nut with washer, 10 mm



2 Corrugated tubes

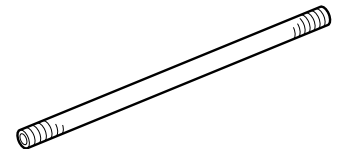

## TOOLS AND SUPPLIES REQUIRED

10 mm Wrench  
Clip remover  
Piece of wire  
Diagonal cutters  
Tape measure  
Utility knife  
Scissors  
Ratchet wrench  
10 mm and 14 mm Sockets  
Felt-tip pen  
Drill  
3 mm, 6 mm, 8 mm, and 10 mm Drill bits  
Center punch  
Duct tape  
Masking tape  
Touch-up paint  
Eye protection (face shield, safety goggles, etc.)  
Vinyl tape  
Cardboard or shop towel

### *Illustration of the XM Radio System Installed on the Vehicle*

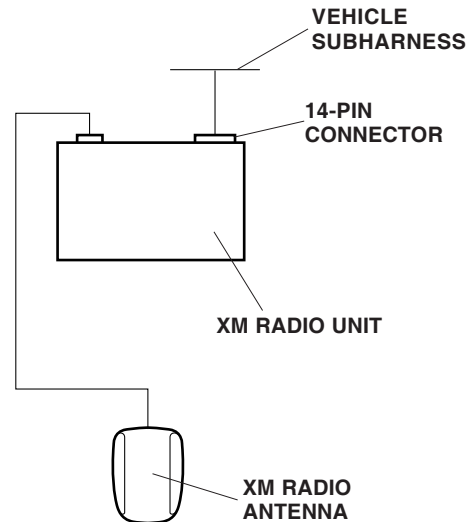
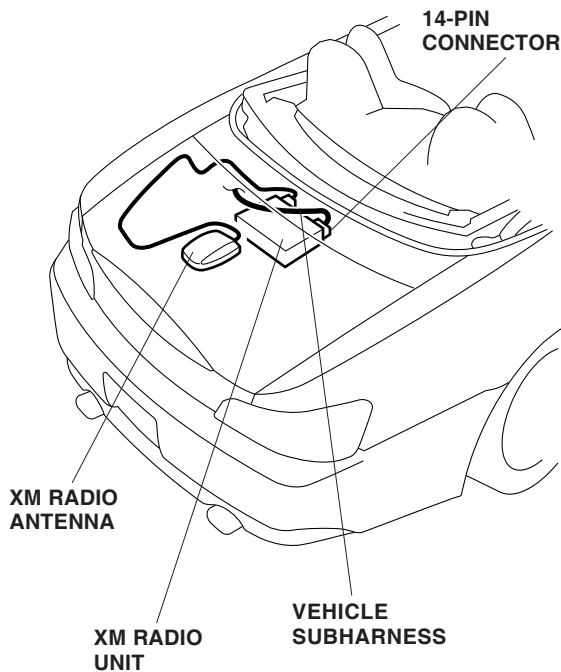

## INSTALLATION

**Customer Information:** The information in this installation instruction is intended for use only by skilled technicians who have the proper tools, equipment, and training to correctly and safely add equipment to your vehicle. These procedures should not be attempted by “do-it-yourselfers.”

1. Make sure you have the anti-theft code for the radio, then write down the radio station presets.
2. Disconnect the negative cable from the battery.
3. Open the trunk lid, and remove the tool tray. Remove the three clips that secure the spare tire cover, and remove the cover.
4. Remove the anchor bolt and the spare tire.

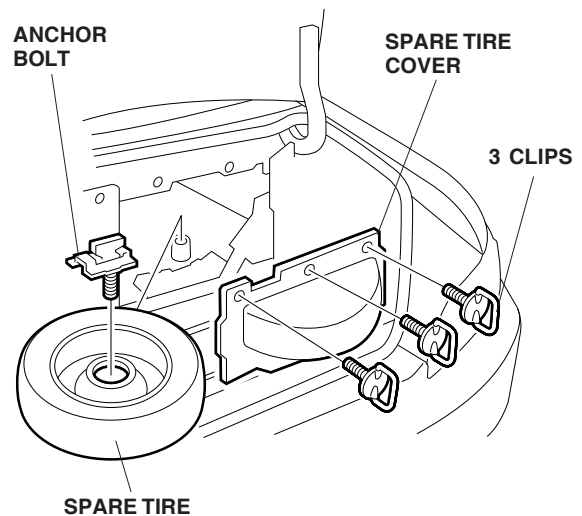

- Remove the six clips that secure the left trunk side trim panel, and remove the panel.

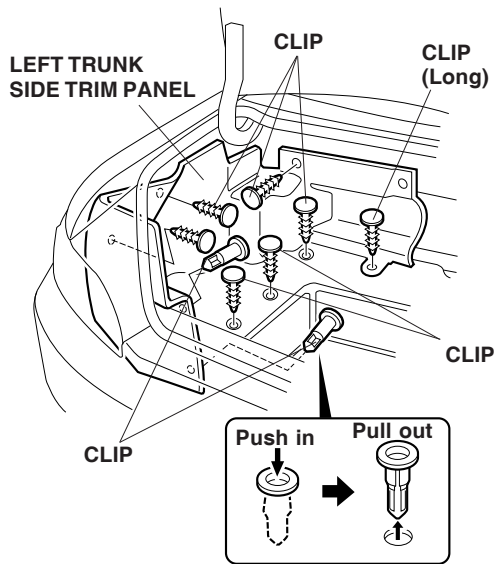

### Installing the XM Radio Bracket

- Inside the trunk, pull out the vehicle subharness beside the fuel tank by cutting the vehicle clip with wire tie. Take care not to damage the vehicle harness when cutting the wire tie.

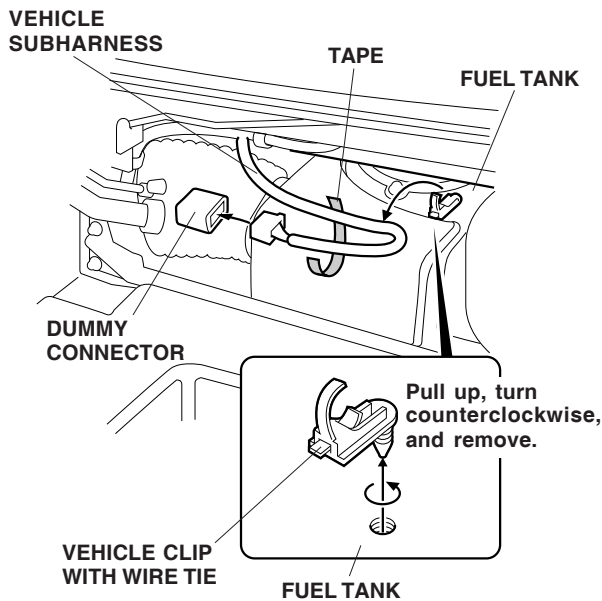

- Remove the vehicle clip with wire tie from the fuel tank.
- Remove the tape from the vehicle subharness, and free the harness. Remove the dummy connector from the subharness connector.

- Locate the three concealed welded nuts under the insulator.
  - Using scissors, cut the template in the position as shown.

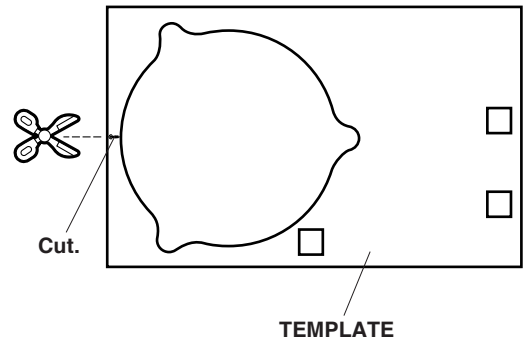

- Position the template on the insulator of the fuel tank.
- Using a felt-tip pen, mark the inner edge of the three squares.

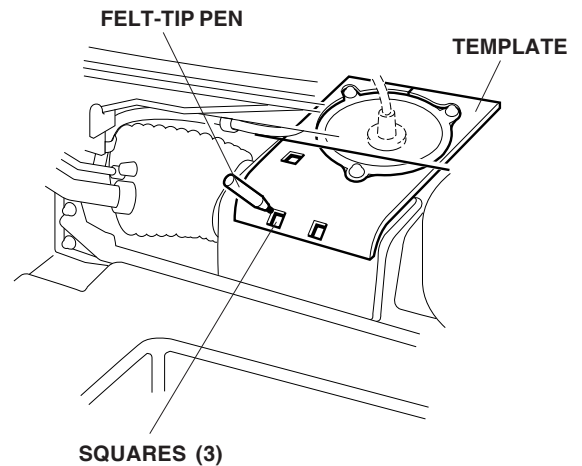

- Using a utility knife, cut the square out of the insulator, then locate the welded nut. Remove the insulator adhesive tape from around the nut threads, and thoroughly clean the area. Do not drop debris into the nut.

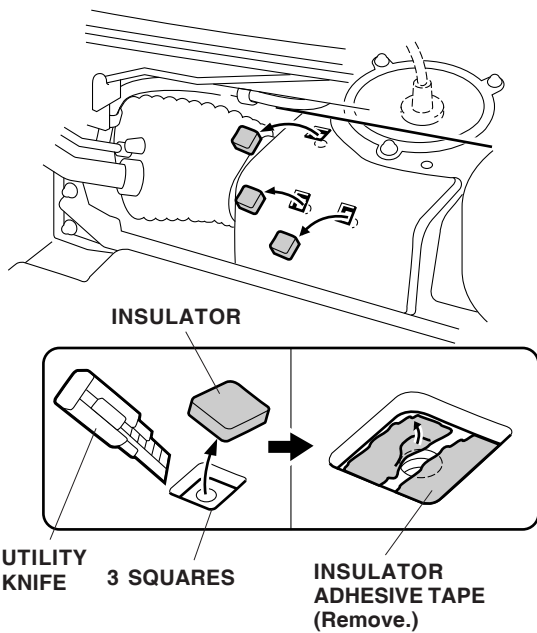

- Position the XM radio bracket on the insulator, and align the four holes in the bracket with the four welded nuts in the fuel tank. Install two 6 x 10 mm washer-bolts to the bracket, and temporarily tighten them. Install two 6 x 10 mm washer-bolts to the rear of the bracket, and temporarily tighten them. Tighten the front two bolts securely, then tighten the rear two bolts.

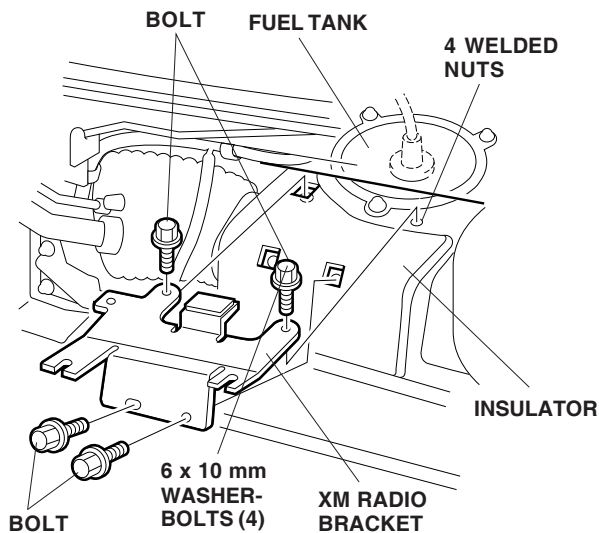

## Installing the XM Radio Antenna

- Using scissors, cut out the template, and fold the three tabs along the dotted lines.

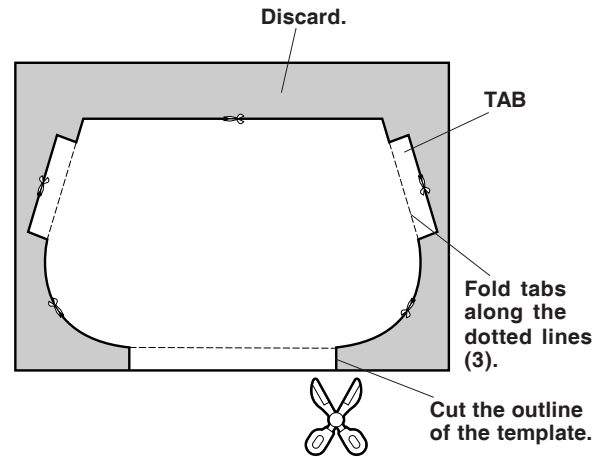

- Position the template on the back of the trunk lid. Use masking tape to secure the template while aligning the dotted lines on the template with the edges of the panel in the trunk lid.
- Lightly center-punch the template as marked, then remove the template.

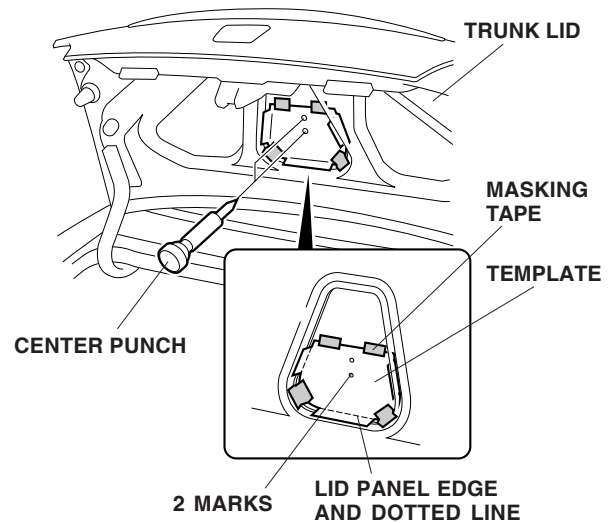

14. While wearing eye protection, drill a 10 mm hole through the trunk lid at the center-punched marks.
  - To prevent metal shavings from dropping in between the inner panel and the outer panel of the trunk lid, wrap duct tape around the inner panel and outer panel. Place cardboard or a shop towel under the trunk lid as shown.
  - Drill first with a 3 mm bit, next with a 6 mm bit, then with an 8 mm bit, and finish with a 10 mm bit.

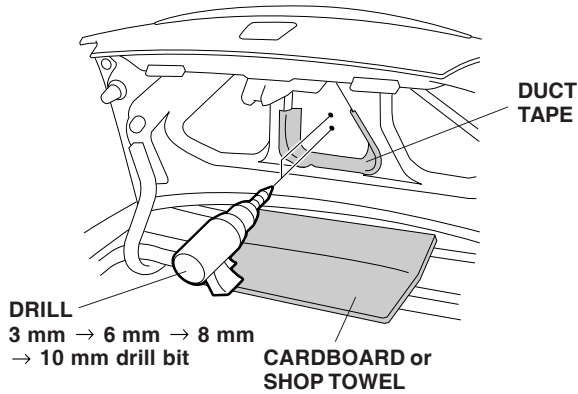

- Remove all burrs and metal shavings. Apply touch-up paint to the edge of the hole you drilled, and let the paint dry completely.
- After drilling, vacuum any metal shavings.

15. From the trunk lid, route the antenna cable through the rear 10 mm hole you just drilled. Insert the stud of the antenna into the front 10 mm hole.

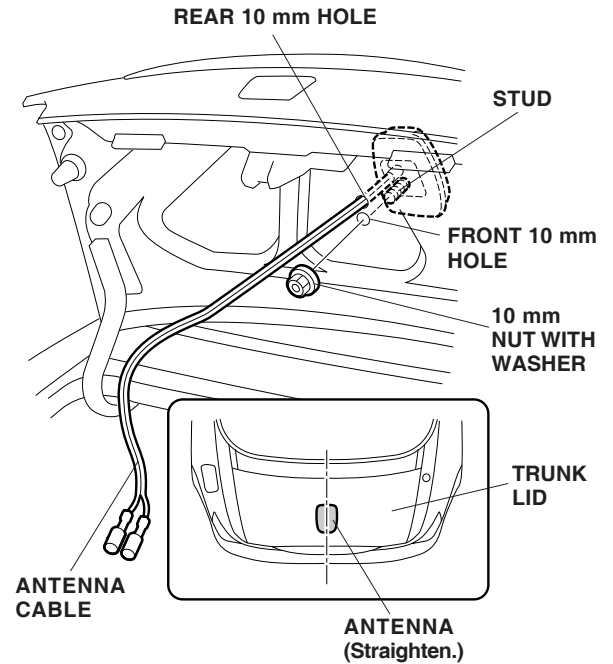

16. Inside the trunk lid, temporarily fasten the 10 mm nut with washer to the stud.
17. Above the trunk lid, make sure the antenna is straight on the trunk lid. Torque the 10 mm nut with washer to 11 lb-ft (15 N·m).
18. Cut a piece of EPT sealer into a 25 mm x 35 mm piece, and wrap the 25 mm x 35 mm piece around the antenna cable at the end against the trunk lid panel.

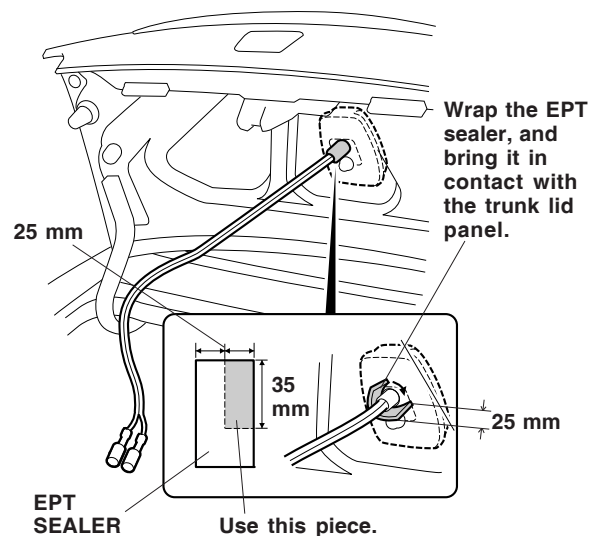

19. Install the two corrugated tubes onto the antenna cable using vinyl tape in the areas shown.

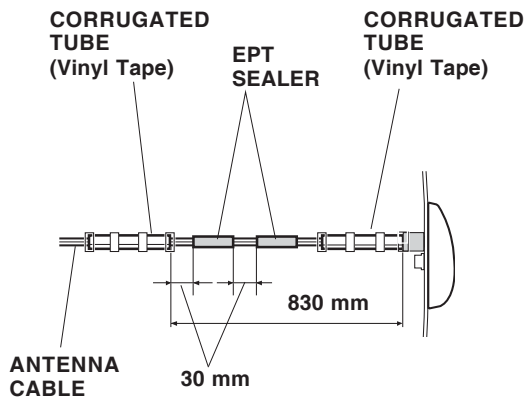

20. Wrap two EPT sealers around the antenna cable between the corrugated tubes, as shown.

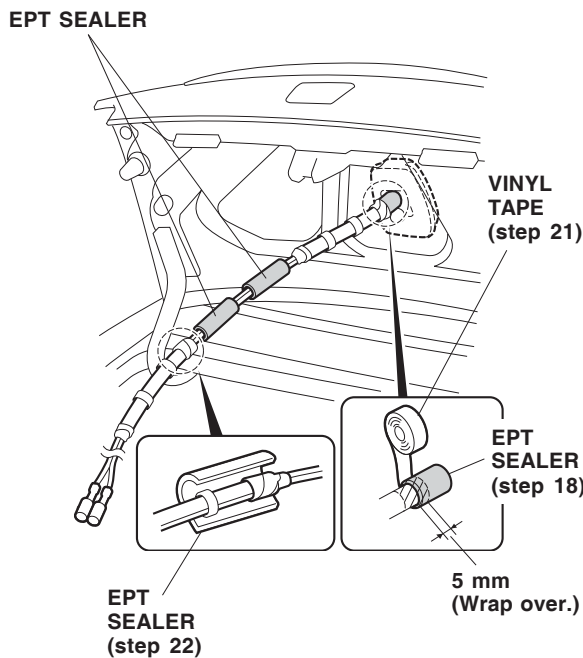

21. Wrap vinyl tape around the end of the corrugated tube and the EPT sealer at the trunk lid panel.
22. Wrap one EPT sealer around the end of the other corrugated tube, as shown.

23. Route the antenna cable through the trunk lid panel holes in the areas shown.

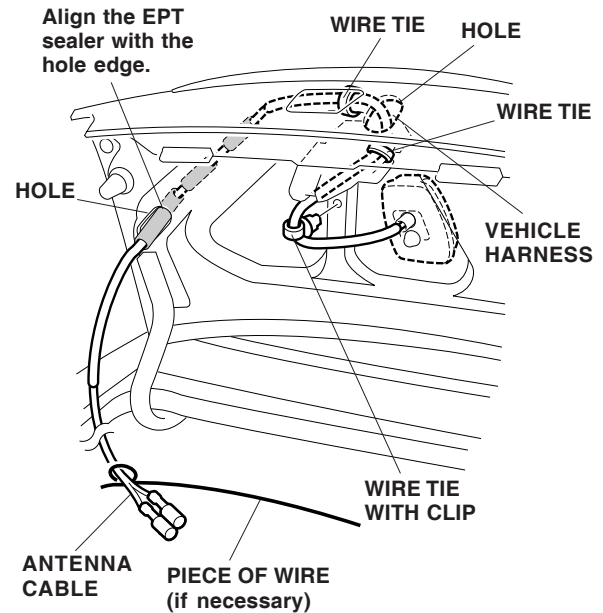

24. Get one wire tie with clip from the kit. Push the clip of the wire tie into the trunk lid panel clip hole, and secure the antenna cable to the panel with the wire tie.
25. Secure the antenna cable to the vehicle harness at the front of the trunk lid panel hole and inside the hole with two wire ties.
26. Route the antenna cable along the vehicle harness at the trunk lid hinge arm, and secure it to the vehicle harness with three wire ties in the areas shown.

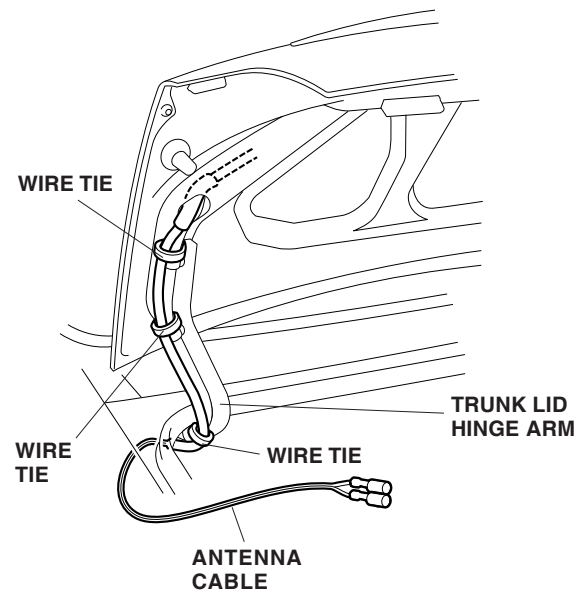

27. Get the 2-pin connector from the kit. Firmly push the terminal into the connector until it clicks into the correct position.

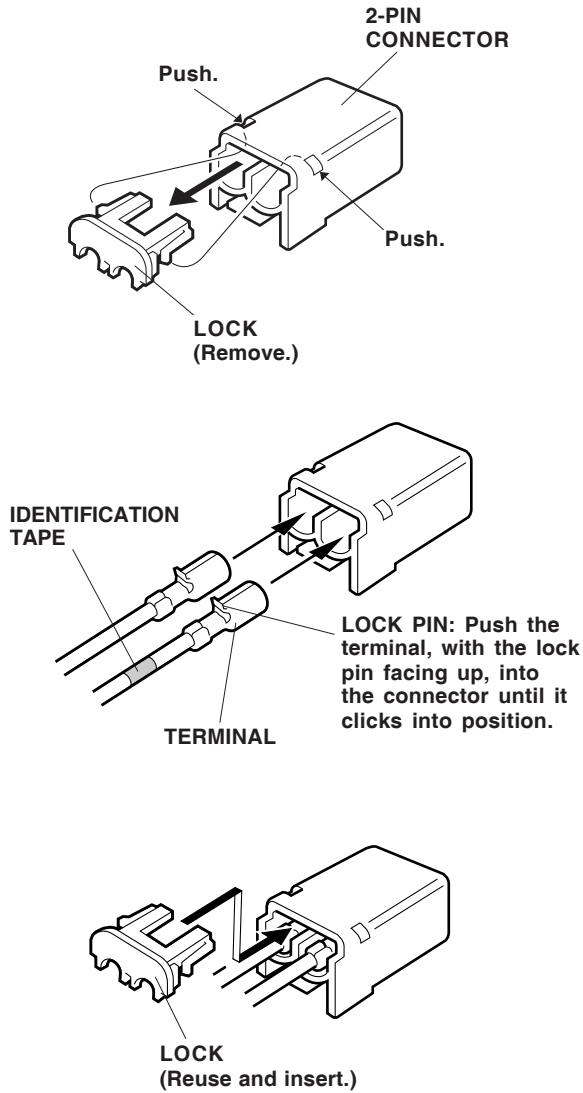

28. Route the antenna cable along the vehicle harness, and secure the cable to the vehicle harness with two wire ties in the areas shown.

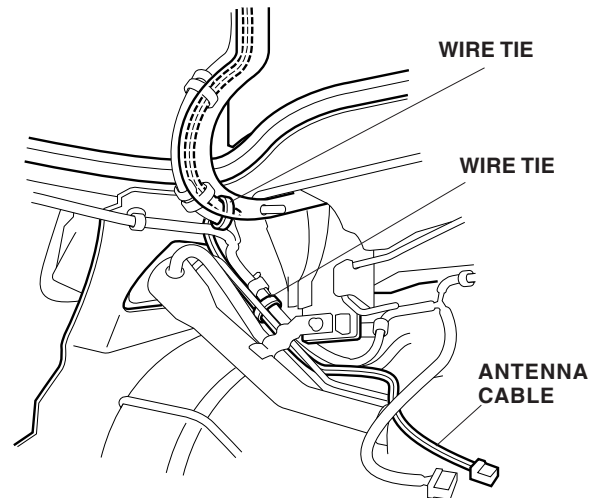

### Installing the XM Radio Unit

#### With CD Changer:

- Use the bus cable from the CD changer attachment kit.
- For installation of the bus cable, refer to the CD changer installation instruction.

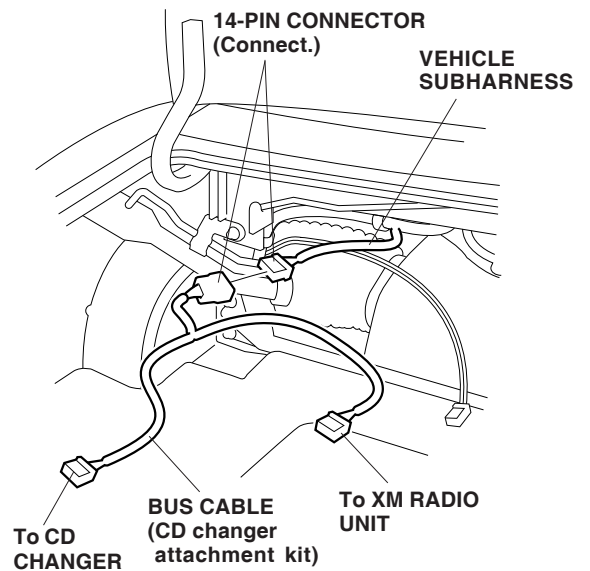



29. Push the clip of the other wire tie with clip into the XM radio bracket hole.

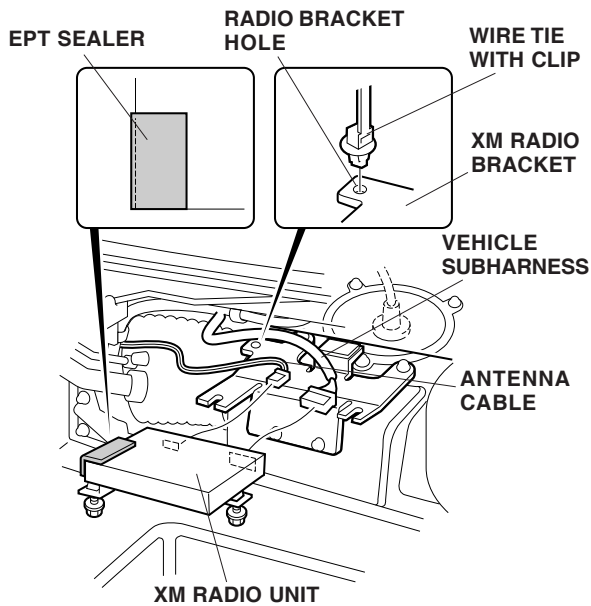

30. Attach the EPT sealer to the XM radio unit corner edge where the antenna cable and vehicle harness will contact. Place half the EPT sealer on the top surface and half on the side.
31. Plug the antenna cable and vehicle subharness connector into the XM radio unit.
32. Loosen the two XM radio unit bolts, and insert their threads into the slits in the XM radio unit bracket.

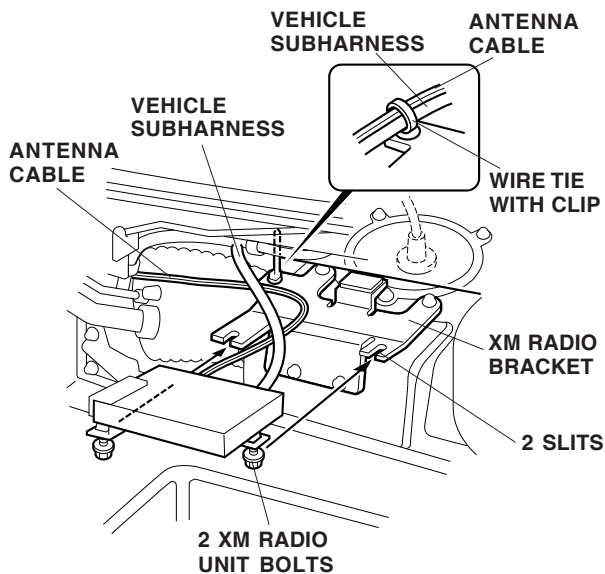

33. Tighten the two XM radio unit bolts securely.
34. Attach the wire tie with clip installed in step 29 to the antenna cable and the vehicle subharness.

35. Secure the antenna cable to the vehicle harness with one wire tie, as shown.

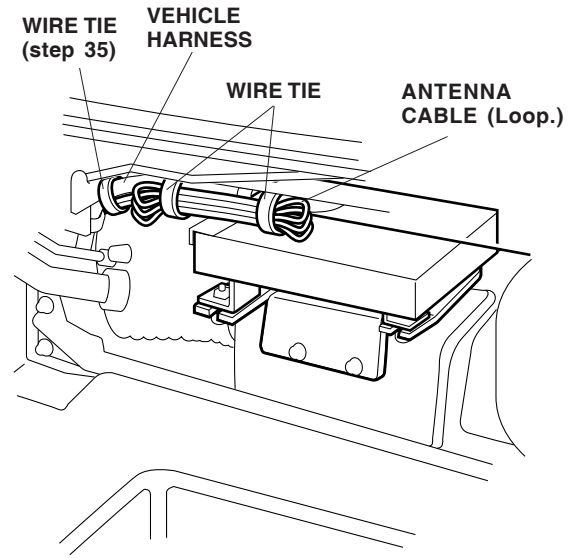

36. Loop the antenna cable, and secure it to the vehicle harness with two wire ties.
37. Check that all wire harnesses and cables are routed properly and that all connectors are plugged in. Open and close the trunk lid several times, and visually check that the antenna cable has not been pinched around the trunk hinge arm.
38. Reinstall all removed parts. Check that all clips and all other fasteners are installed securely.
39. Reconnect the negative cable to the battery.
40. Enter the customer's radio anti-theft code, and reset the radio station presets.
41. Reset the clock.
42. Activate the XM Satellite Radio demo service, and then check the operation of the XM radio system according to the vehicle owner's manual.