



INSTALLATION INSTRUCTIONS

Accessory
**BICYCLE ATTACHMENT
(HITCH MOUNT)**
P/N 08L14-TA1-100

Application
2009 RIDGELINE

Publications No.
All 40288
Issue Date
AUG 2008

Put this information in the glove box with the vehicle owner's manual.

PARTS LIST

Upright assembly

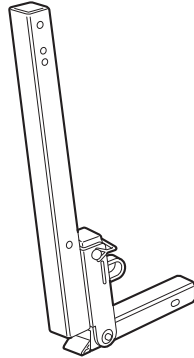

Bicycle arm bracket

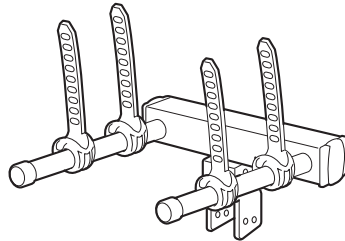

Bolt



Torx bolts



2 Washers, 10 mm



Washer, 12 mm



Lock washer



Nut, 6 mm



Nut, 10 mm



Tie-down bar

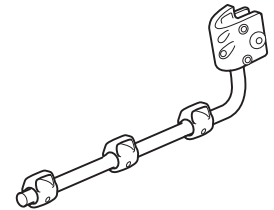

Hitch tool

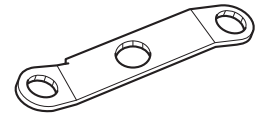

Torx wrench



Allen bolt

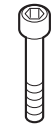

Hex key

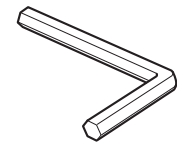

4 Straps



INSTALLATION

NOTE

- Be careful not to damage the finished surfaces of the body when installing the bicycle carrier.
 - No more than 2 bicycles should be carried on the bicycle rack.
1. Slide the upright assembly into the trailer hitch receiver until the hole in the tube lines up with the receiver hole. Install the bolt with lock washer and 12 mm washer through the receiver hole. Tighten the bolt securely.

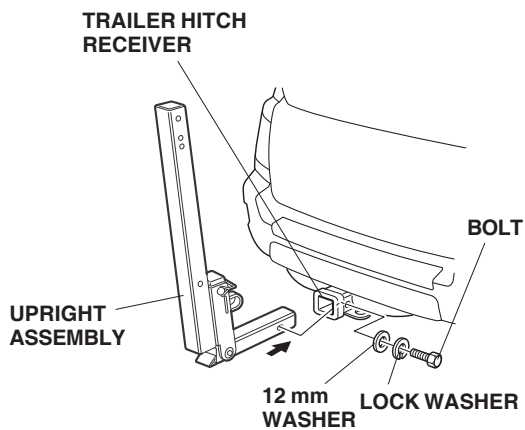

2. Position the bicycle arm bracket onto the upright assembly as shown.

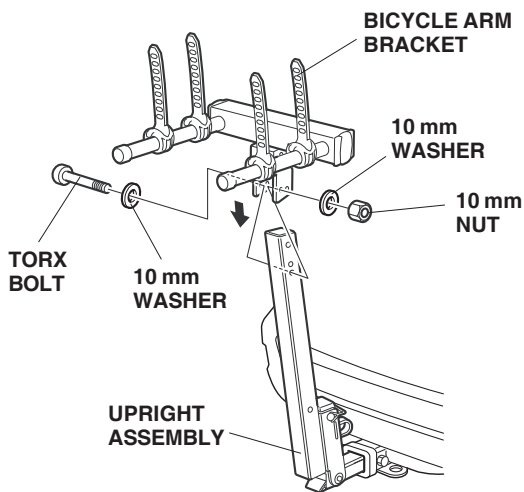

3. Install the torx bolt with two 10 mm washers and the 10 mm nuts. Tighten the torx bolt securely.

4. Install the pin and safety hook as shown.

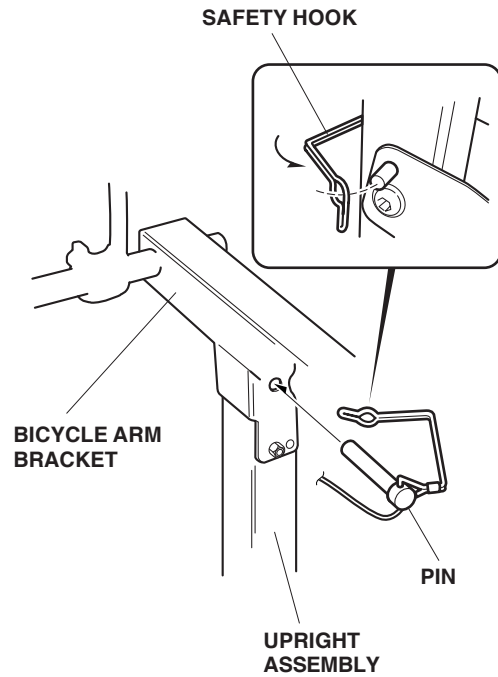

5. Align the tie-down bar with the upright assembly, then secure it with the allen bolt and 6 mm nut.

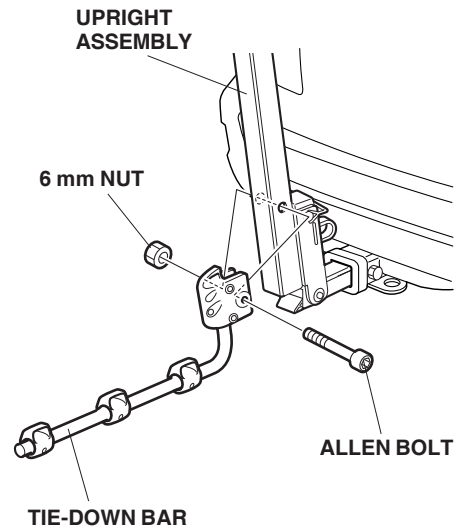

Loading the Bicycles

1. Load the heaviest bicycle first onto the innermost cradle. The cradles can be rotated or shifted on the bars to accommodate different bicycle geometries.

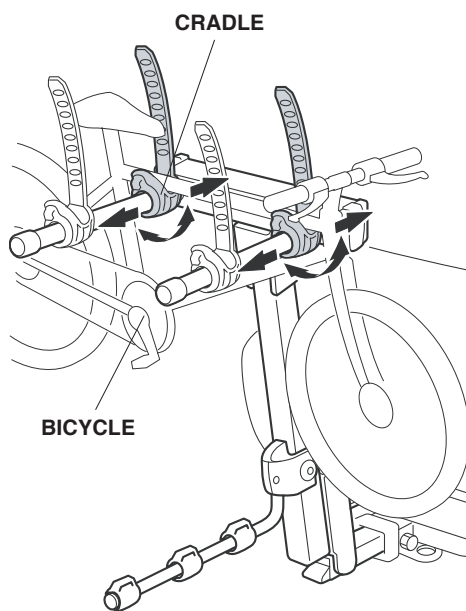
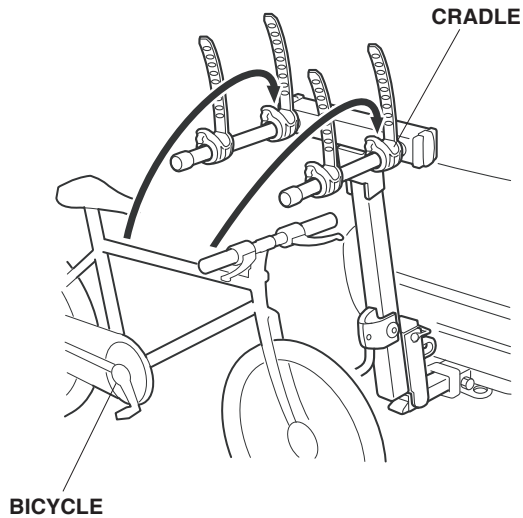

2. When loading two bicycles, alternate the direction of the bicycles.

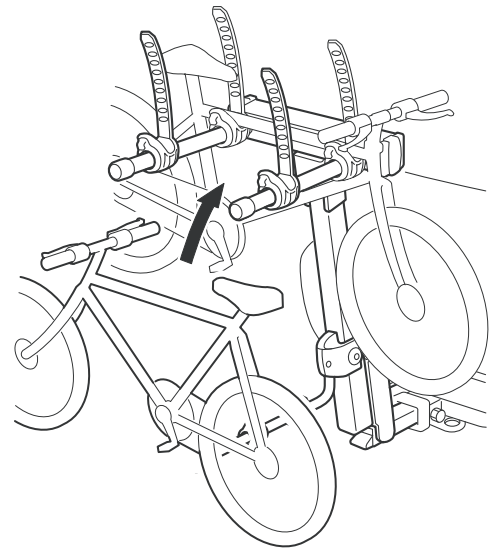

3. Tighten the bicycle arm straps securely around the bicycle frame.

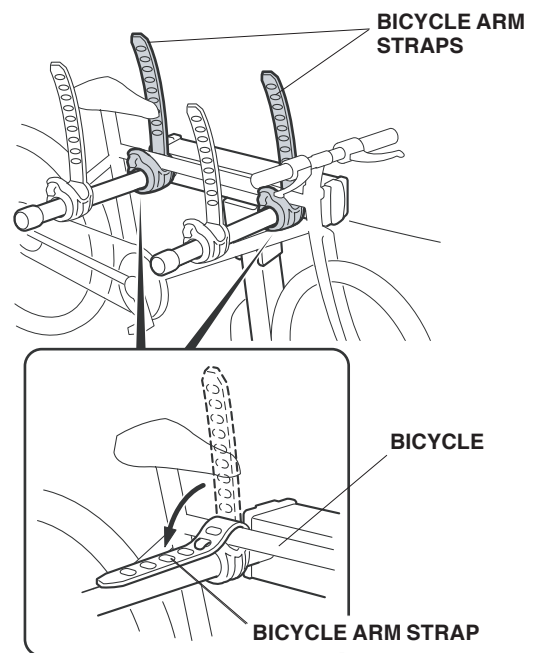

4. Using the straps provided, secure the bicycles to the tie-down bar (either through the bicycle wheels or the frame.)
 - Secure the inner bicycle to the **A** position on the tie-down bar.
 - Secure the second bicycle to the **B** or **C** position on the tie-down bar.
 - Secure the strap buckle as shown.
 - After loading the bicycle, confirm that the rear taillights can still be seen from the rear.

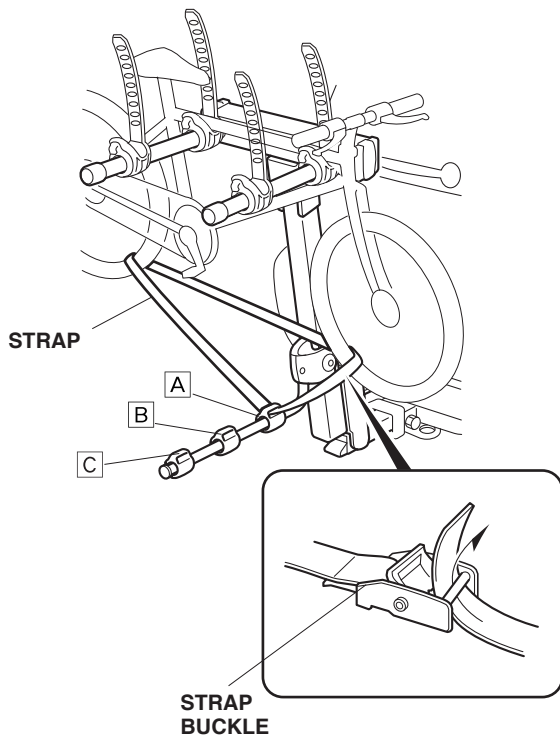

Storing the Rack when no Bicycles are Loaded

1. Release the safety hook by pulling outward on the untethered end. Slide the pin out while supporting the upright assembly. Gently lower the bicycle arm bracket to the stop position.

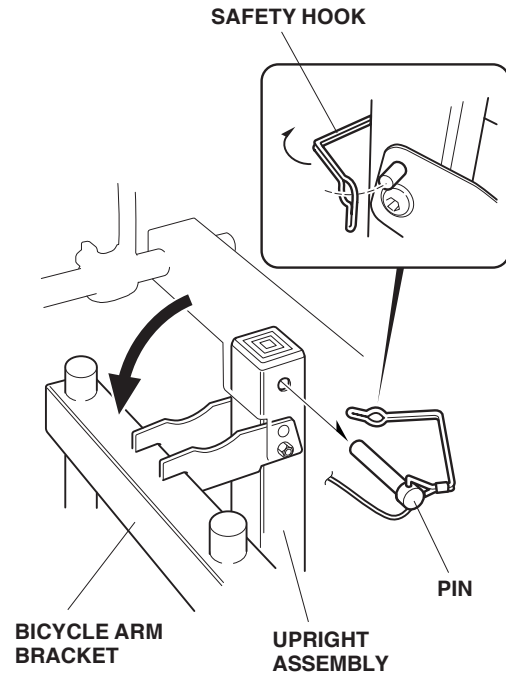

2. Reinstall the pin and safety hook.

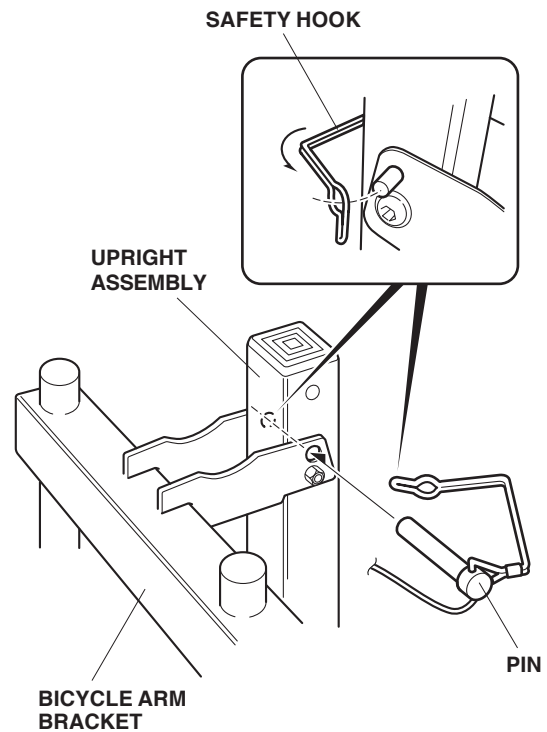

3. Turn the tie-down bar 90° in the direction shown. This is the stored position.

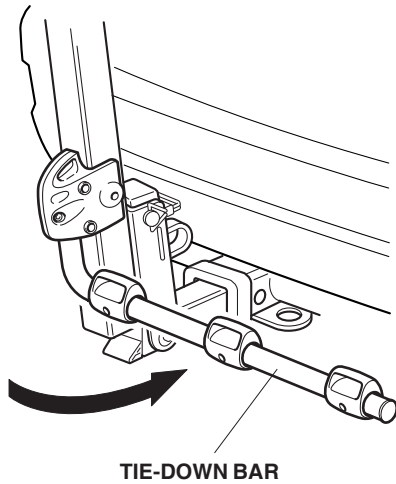

Opening the Tailgate

1. All bicycles must be removed to lower the carrier. Rotate the tie-down bar 90°, then firmly hold the upright assembly with one hand. Release the safety hook by pulling outward on the untethered end. Slide the pin out while supporting the upright assembly.

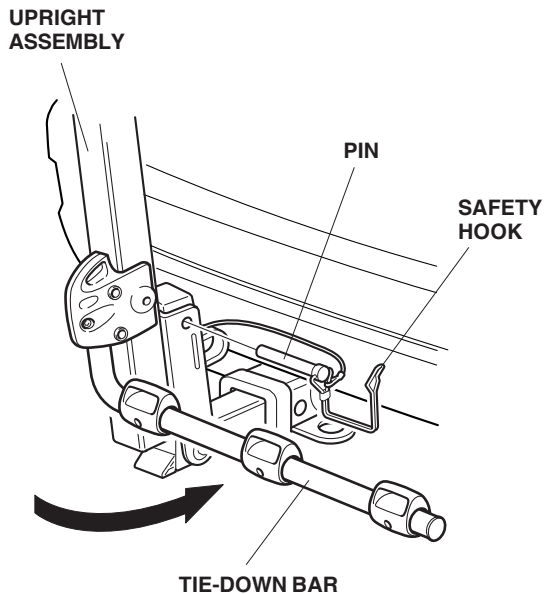

2. Gently lower the bicycle carrier to the stop position.

