



# INSTALLATION INSTRUCTIONS

Accessory  
**PREMIUM RUNNING BOARDS**  
P/N 08L33-SZA-100B

Application  
**2009 PILOT**

Publications No.  
**All 39395**  
Issue Date  
**MAY 2008**

## PARTS LIST

2 Premium running boards

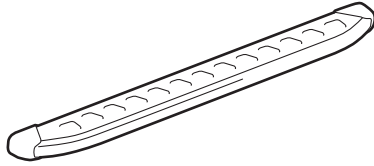

Right bracket A

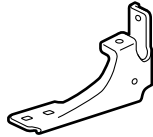

Left bracket A

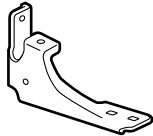

2 Right brackets B

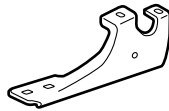

2 Left brackets B

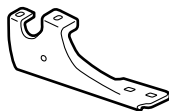

12 Flange bolts

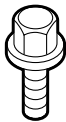

12 flange nuts



2 Rivnuts

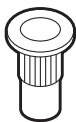

12 Square head bolts



## TOOLS AND SUPPLIES REQUIRED

Torque wrench

Socket

27 mm Wrench

Hex wrench

Rivnut tool

T/N LEML722M8

*Illustration of the Premium Running Boards Installed on the Vehicle*

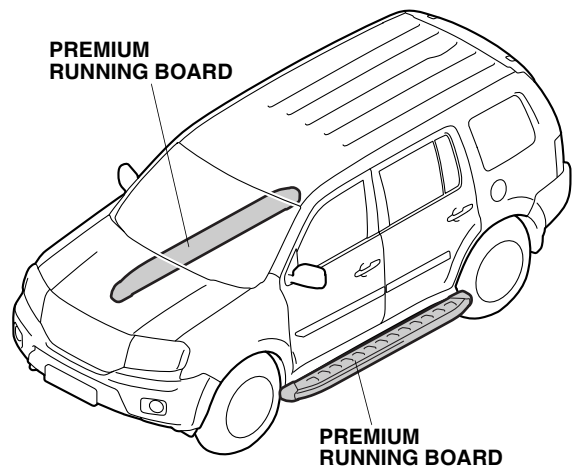

## INSTALLATION

**Customer Information:** The information in this installation instruction is intended for use only by skilled technicians who have the proper tools, equipment, and training to correctly and safely add equipment to your vehicle. These procedures should not be attempted by “do-it-yourselfers.”

### NOTE:

- Thoroughly clean the bottom of the body from the rear of the front wheels up to the front of the rear wheels.
- Be careful not to damage the body paint finish. To prevent damage, place a blanket under the premium running board during the installation.
- These instructions show the left premium running board being installed; the same procedure applies to installing the right premium running board.

1. Install the rivnut to the vehicle frame as shown.

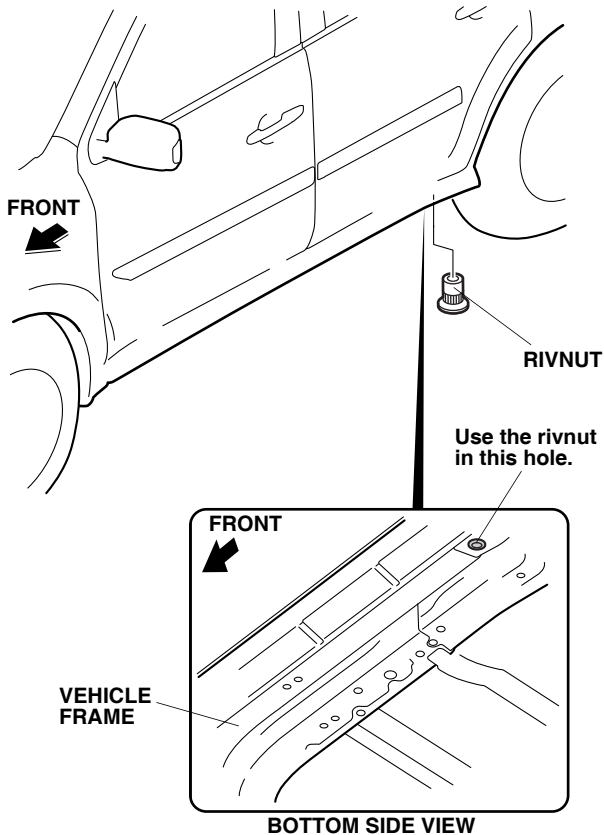

- Screw the rivnut onto the mandrel of the rivnut tool as shown.

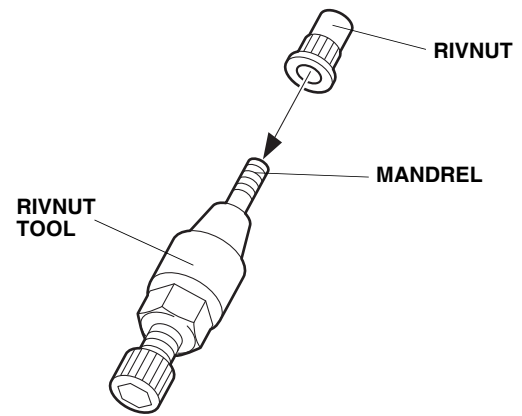

- Insert the rivnut into the hole in the vehicle frame and install the hex wrench on the rivnut tool.

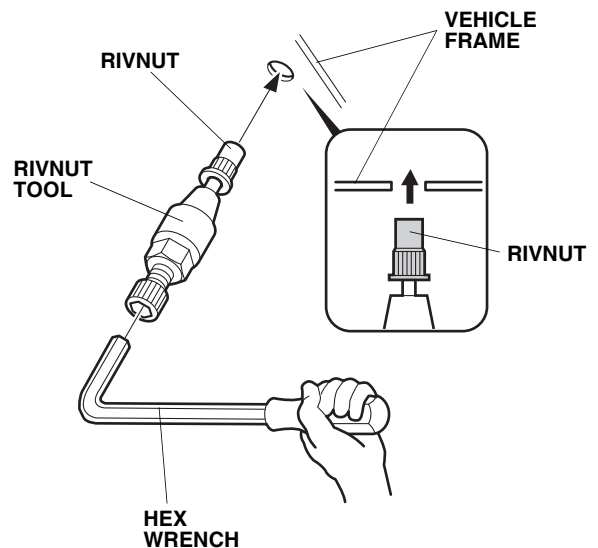

- Holding the rivnut tool with the hex wrench, turn the 27 mm wrench clockwise and install the rivnut on the vehicle frame.
- Remove the rivnut tool from the rivnut by turning the hex wrench counterclockwise.

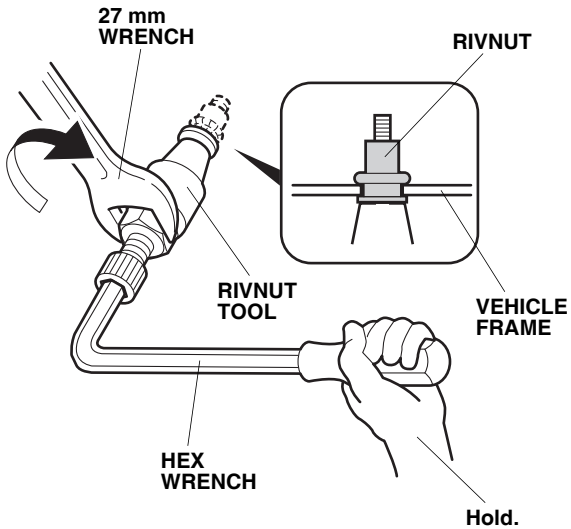

2. Position the left bracket A at the respective installation positions of the vehicle frame. Install the left bracket A on the vehicle frame with the two flange bolts. Do not tighten the flange bolts yet. Make sure the flange bolts are installed in the correct positions.

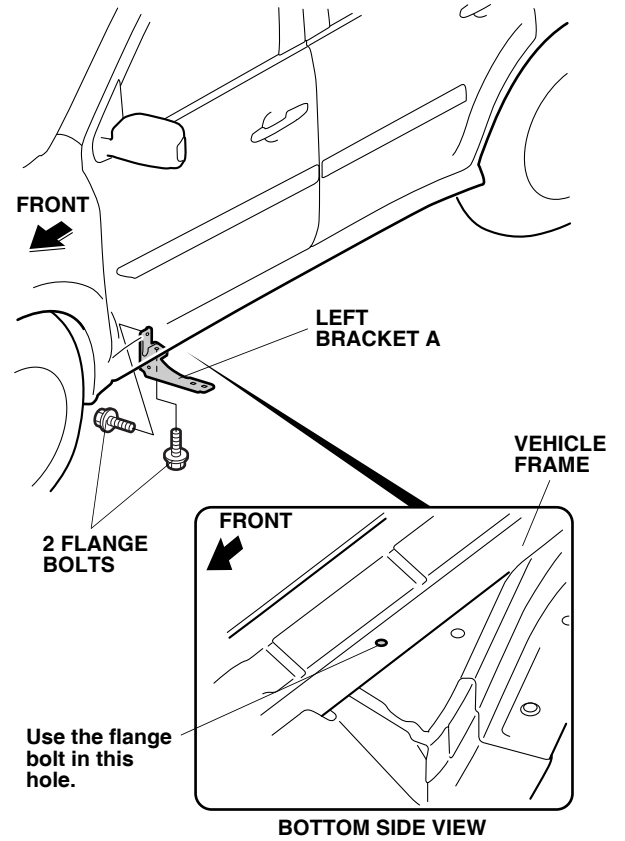

- Position the left two brackets B at the respective installation positions of the vehicle frame. Install the two left brackets B on the vehicle frame with the two flange bolts for each. Do not tighten the flange bolts yet. Make sure the flange bolts are installed in the correct positions.

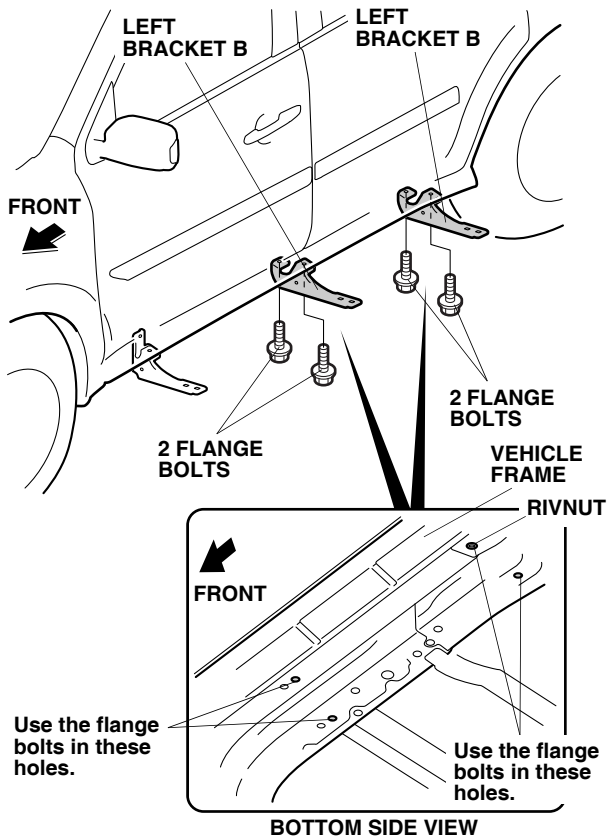

- Slide three square head bolts into each groove on the premium running board.

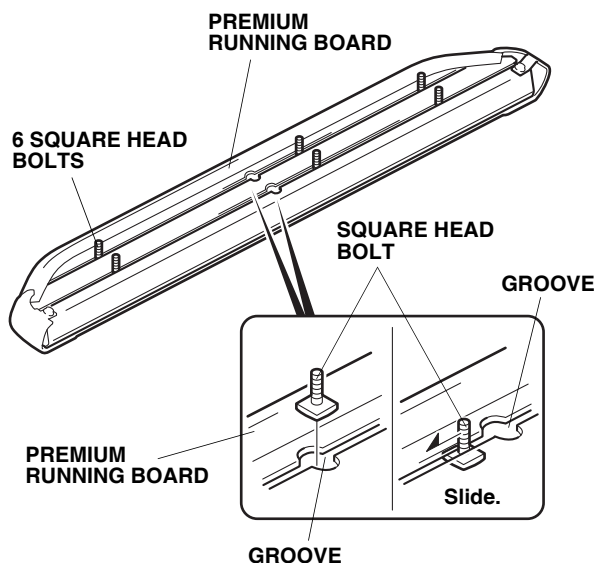

- Position the premium running board on the left bracket A and two left brackets B. Install the premium running board with the six flange nuts. Do not tighten the flange nuts yet.

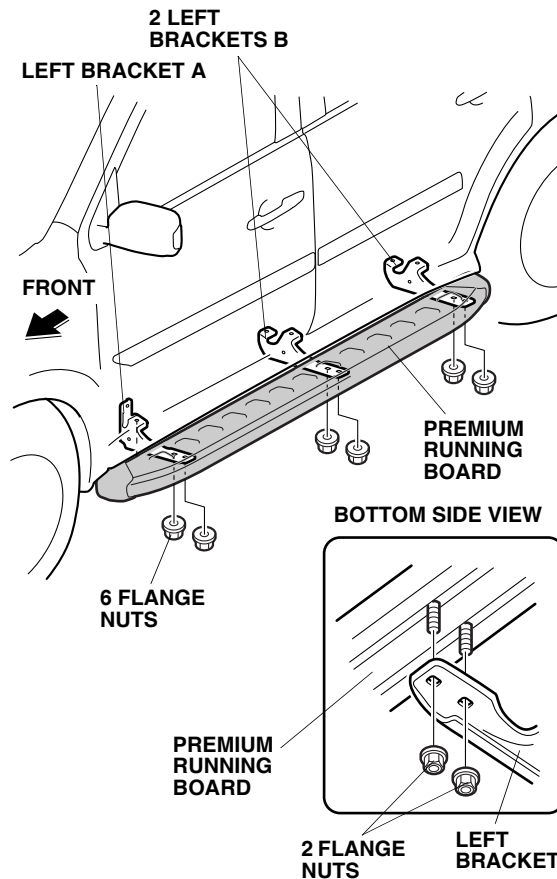

6. Check the center of the premium running board as shown.

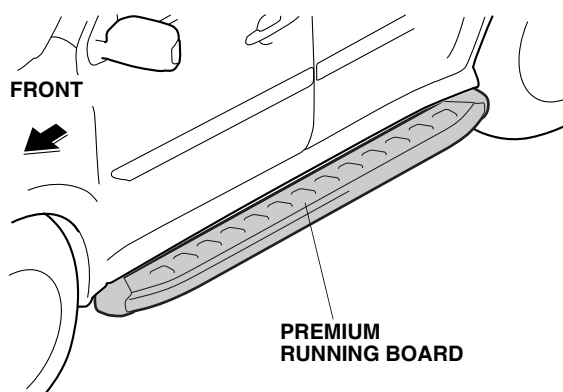
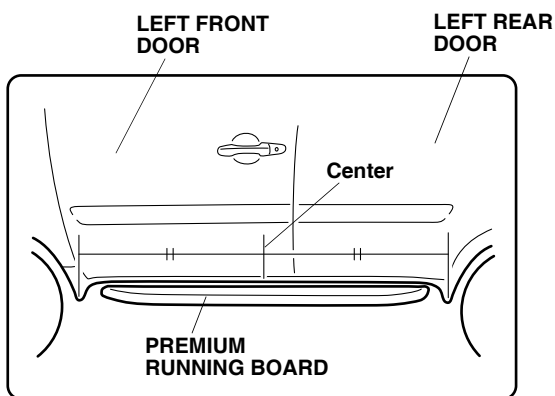

7. Tighten the six flange nuts that were loosely installed in step 5. Torque the flange nuts to 27 N·m (2.7 kgf·m, 19 lbf·ft).
8. Tighten the six flange bolts that were loosely installed in step 2 and step 3. Torque the flange bolts to 27 N·m (2.7 kgf·m, 19 lbf·ft).
9. Repeat steps 1 through 8 to install the premium running board on the right side of the vehicle.