



INSTALLATION INSTRUCTIONS

Accessory

FRONT UNDER SPOILER

Application

2009 CIVIC
4-DOOR

Publications No.

All 40131

Issue Date

AUG 2008

PARTS LIST

Front under spoiler

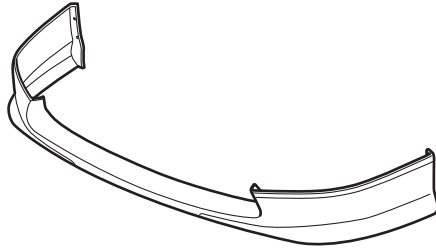

4 Self-tapping screws

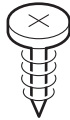

4 Flange bolts

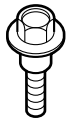

4 Flange nuts



4 Spring nuts



Spacer

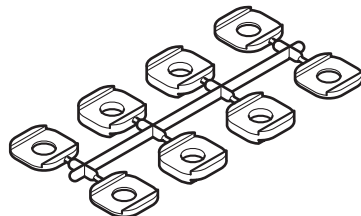

TOOLS REQUIRED

Phillips screwdriver

Flat-tip screwdriver

Drill

3 mm and 10 mm Drill bits

Diagonal cutters

Clip remover

Pushpin

File

Blanket

Masking tape

Isopropyl alcohol

Shop towel

Eye protection (face shield, safety goggles, etc.)

INSTALLATION

Customer Information: The information in this installation instruction is intended for use only by skilled technicians who have the proper tools, equipment, and training to correctly and safely add equipment to your vehicle. These procedures should not be attempted by "do-it-yourselfers."

NOTE:

- Using isopropyl alcohol on a shop towel, thoroughly clean the area where the front under spoiler will be attached. Use a shop towel to apply the isopropyl alcohol and wipe up spills at once. Allow the isopropyl alcohol to dry thoroughly before attaching the front under spoiler.
- Be careful not to damage the front bumper and body paint finish.
- This front under spoiler kit should be installed only if the ambient air temperature is 60°F (15°C) or above.
- To allow the adhesive to cure, do not wash the vehicle for 24 hours.

1. Remove the five clips. Remove the front bulkhead cover by displacing the right and left fender trim inward.

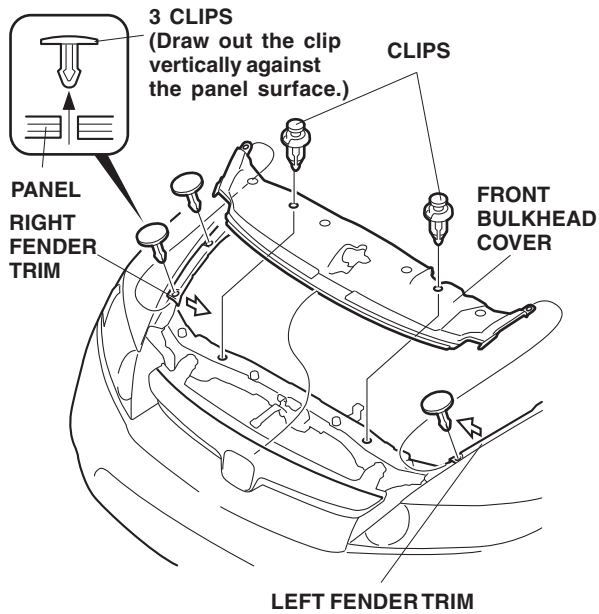

2. With the help of assistant, remove the front bumper (four bolts, four long clips fastening the front bumper and air spoiler, six clips, and two self-tapping screws). Unplug the fog light and/or the front corner sensor connectors, if equipped. Place the front bumper on a blanket to install the front under spoiler. Do not remove the clips fastening the air spoiler.

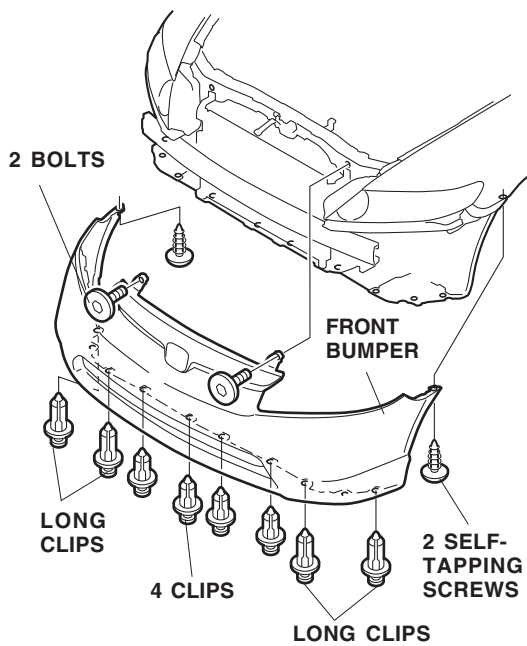

3. Inside the bumper, locate the scribe marks, and make a hole through each mark with a pushpin.

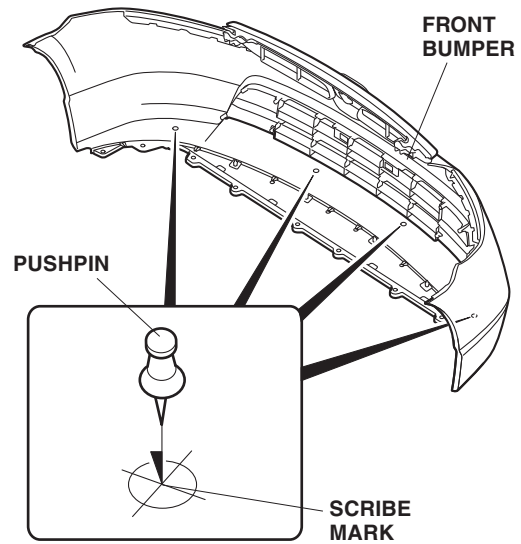

4. While wearing eye protection, drill a 10 mm hole through each marked location from the outside of the bumper. First drill with a 3 mm bit, and finish with a 10 mm bit. Remove any burrs from the edges of the holes with a file.

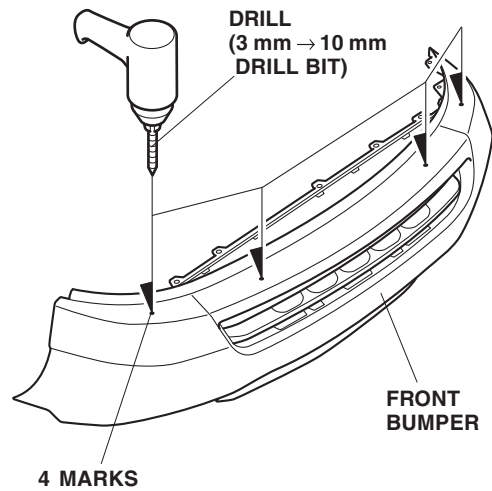

5. While wearing eye protection, drill a 3 mm hole through four dimpled areas of the front bumper on both sides. Remove any burrs from the edges of the holes with a file.

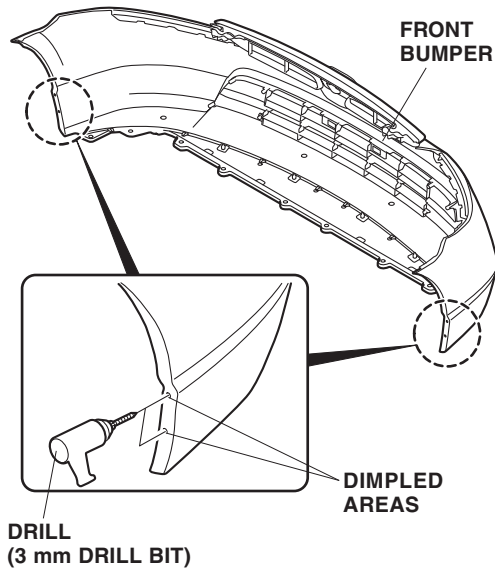

6. Slide spring nuts over the four holes you made in the front bumper.

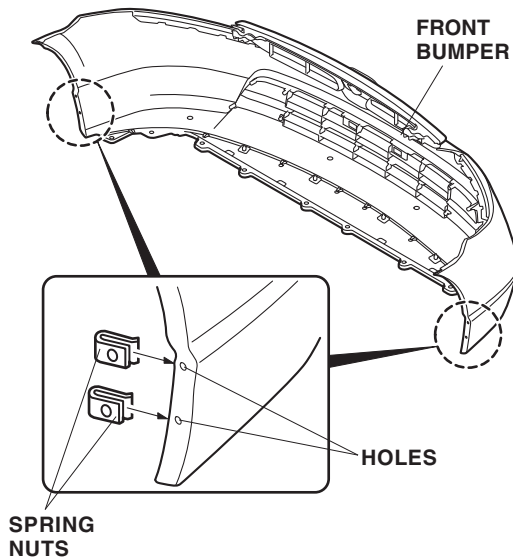

7. Attach a strip of masking tape to the end of each adhesive backing, and peel back 1-1/2 to 2 inches of the adhesive backing. Fold the ends back, and tape them to the front of the front under spoiler.

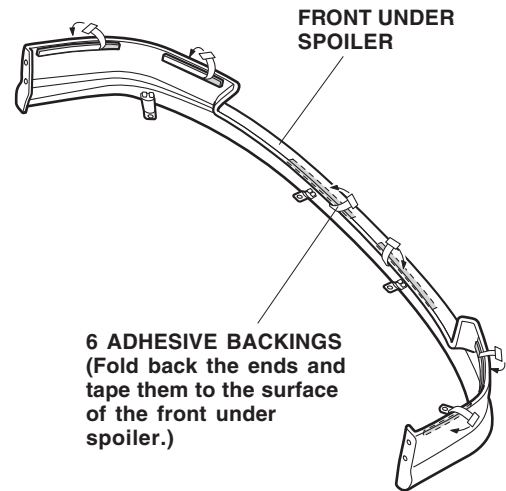

8. Using isopropyl alcohol on a shop towel, clean the front bumper where the front under spoiler will attach.

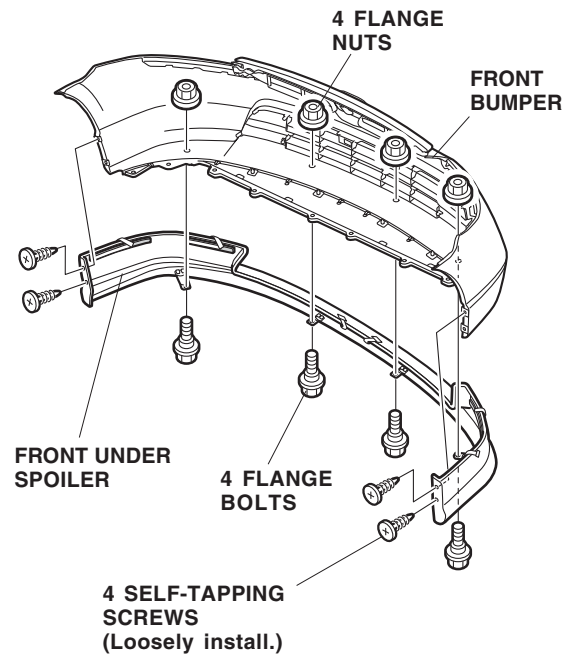

9. Position the front under spoiler on the front bumper, and install a flange nut to each flange bolt.
10. Loosely install the four self-tapping screws.

11. While applying pressure on the front under spoiler, carefully remove the adhesive backings in the sequence shown. After removing, hold the front under spoiler firmly against the front bumper with the palm of your hand for 30 seconds.

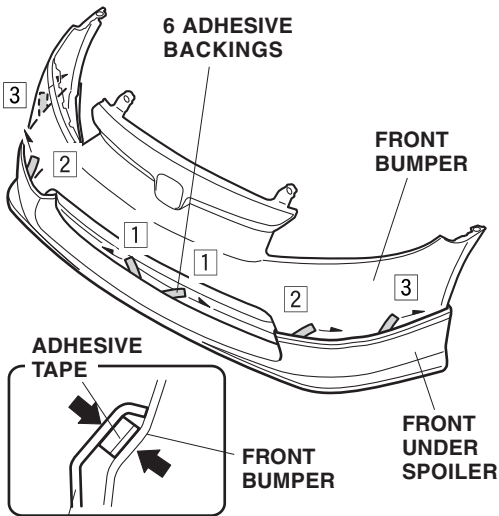

FRONT UNDER SPOILER
(Hold firmly against the front bumper with the palm of your hand.)

12. Tighten the self-tapping screws temporarily installed in step 10.

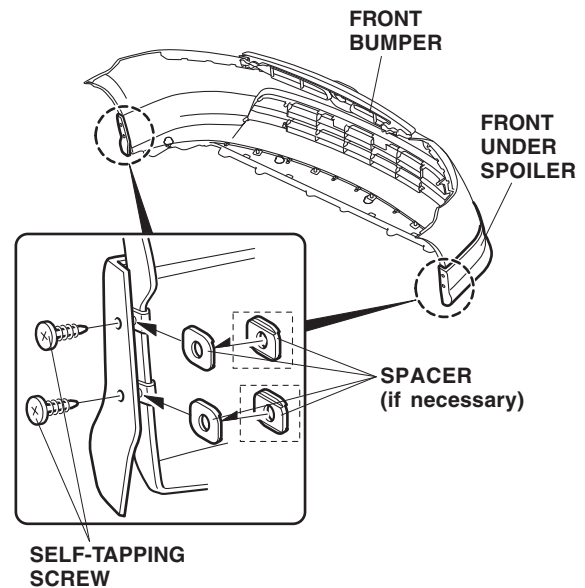

13. Use one (or two) spacer(s) between the front bumper and the front under spoiler to prevent excess gaps as shown, if necessary.
- If there is a gap, use a 1 mm spacer or a 2 mm spacer as shown.
 - Using diagonal cutters cut one end of the spacer to install through the self tapping screw.
 - Do not use two spacers on one self tapping screw.
14. Reinstall the front bumper.
15. Reinstall all removed parts.