



INSTALLATION INSTRUCTIONS

Accessory
REAR UNDER SPOILER
P/N 08F03-TE0-100

Application
2009 ACCORD
2-DOOR

Publications No.
All 39923
Issue Date
JULY 2008

PARTS LIST

Rear under spoiler

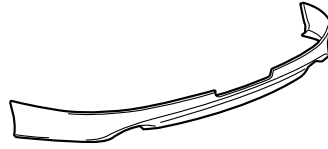

Finisher cover



2 Collars A



2 Collars B



4 Self-tapping screws, 5 x 14 mm



4 Self-tapping screws, 5 x 20 mm

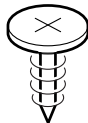

6 Spring nuts



2 Washer bolts



2 Flange nuts



2 Clip retainers



6 Bumper clips

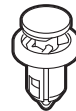

4 Plain washers



Spacers

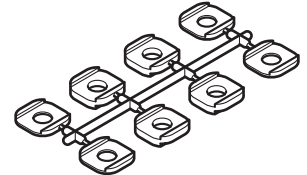

TOOLS AND SUPPLIES REQUIRED

Phillips screwdriver

Clip remover

Eye protection (face shield, safety goggles, etc.)

Drill

3 mm, 8 mm, and 10 mm Drill bits

File

Pushpin

Ratchet

10 mm Socket

10 mm Open-ended wrench

Gloves

Masking tape

Shop towel

Isopropyl alcohol

Reciprocating saw (Snap-on® #AT192A)

Rubber roller (EQSE54D)

INSTALLATION

Customer Information: The information in this installation instruction is intended for use only by skilled technicians who have the proper tools, equipment, and training to correctly and safely add equipment to your vehicle. These procedures should not be attempted by “do-it-yourselfers.”

NOTE:

- Using isopropyl alcohol on a shop towel, thoroughly clean the area where the rear under spoiler will attach. Allow the isopropyl alcohol to dry thoroughly before attaching the rear under spoiler.
- Be careful not to damage the body paint finish.
- This rear under spoiler kit should be installed only if the ambient air temperature is 60°F (15°C) or above.
- Wash and wax the area to be covered. Use a high-quality paste wax.
- To allow the adhesive to cure, do not wash the vehicle for 24 hours.

Installing the Rear Under Spoiler

1. Remove the two covers from the rear bumper and remove the rear bumper (two bolts, six self-tapping screws, two clips, and unplug one connector).

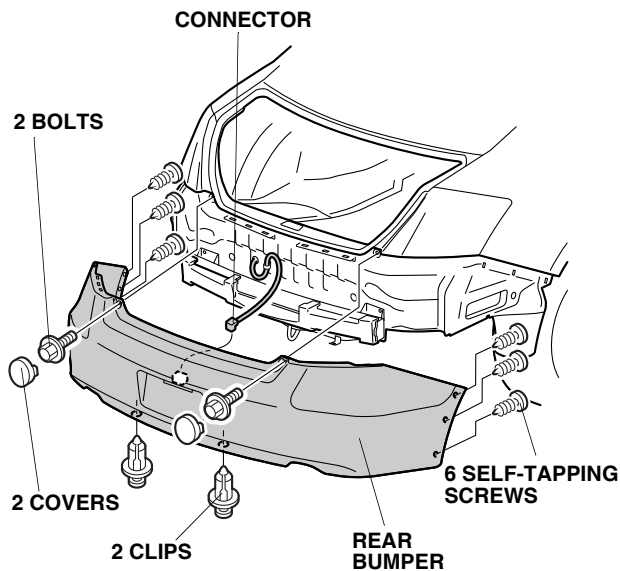

For L4 with a finisher cover, go to step 2.
For V6, go to step 3.

2. Remove the one self-tapping screw and two clips, and pull out the finisher cover from the rear bumper.

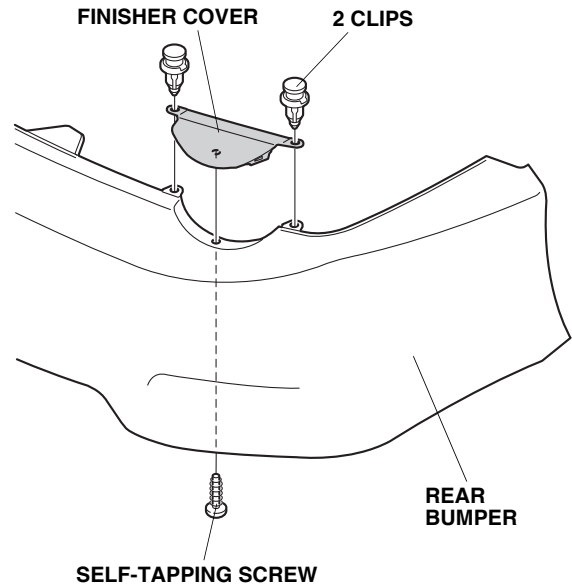

3. While wearing eye protection, use a reciprocating saw to cut out the marked area of the rear bumper. Remove all burrs.

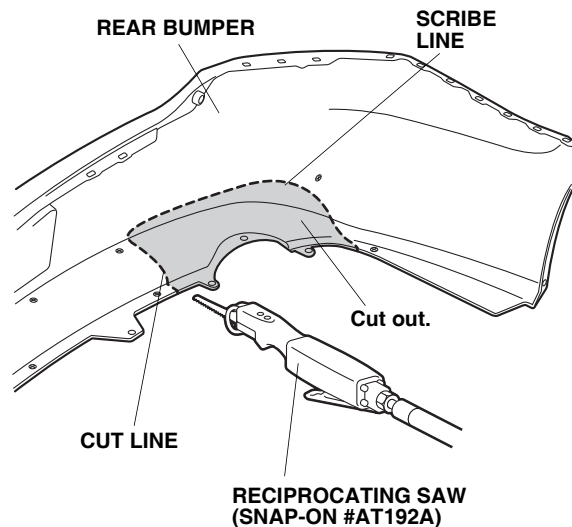

4. Repeat step 3 on the right side.

5. Inside the rear bumper, locate the four scribe marks in the area shown, and pierce the cross sections of the four scribe marks with a pushpin.

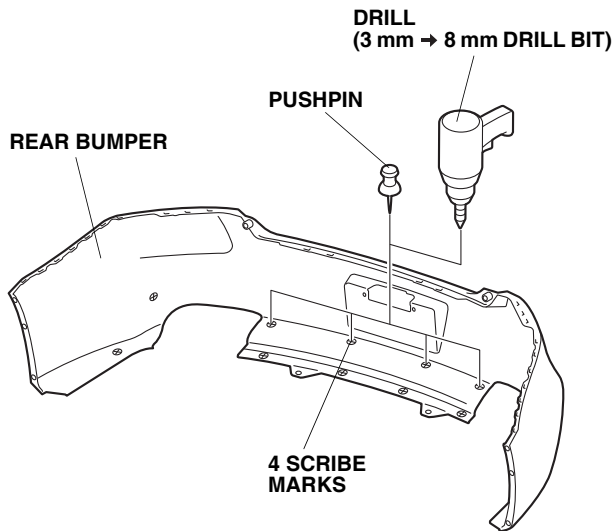

6. While wearing eye protection, drill a 3 mm hole through the mark from the rear bumper as shown. Finish with a 8 mm bit. Remove all burrs.
7. Inside the rear bumper, locate the eight scribe marks in the area shown, and pierce the cross sections of the eight scribe marks with a pushpin.

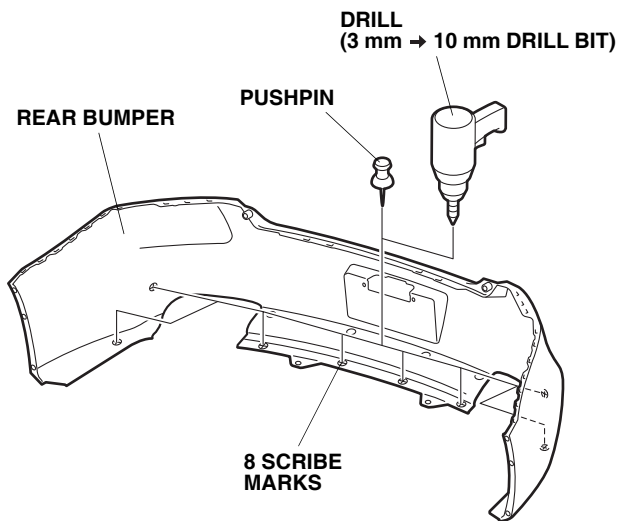

8. While wearing eye protection, first drill a 3 mm hole through the eight scribe marks from the inside of the rear bumper as shown. Finish with a 10 mm bit. Remove all burrs.

9. While wearing eye protection, drill a 3 mm hole through the center of the two dimpled areas on the rear bumper as shown. Remove all burrs.

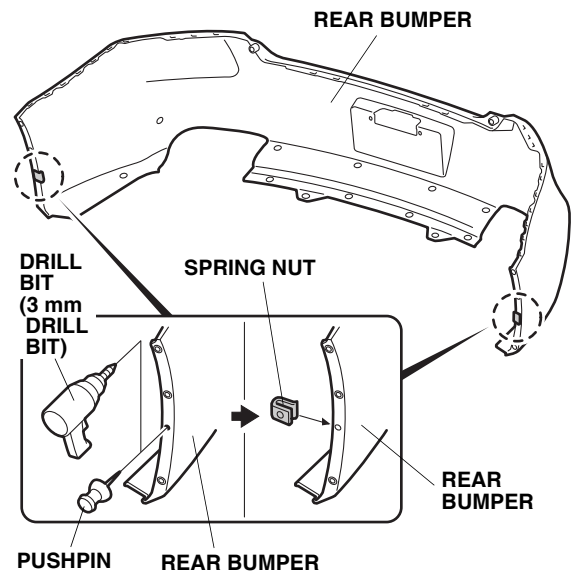

10. Slide two spring nuts over the two holes you made in the rear bumper.

For L4 with a finisher cover, go to step 11. For V6, go to step 16.

11. Inside the rear under spoiler, locate the two scribe marks in the area shown, and pinch the cross sections of the two scribe marks with a pushpin.

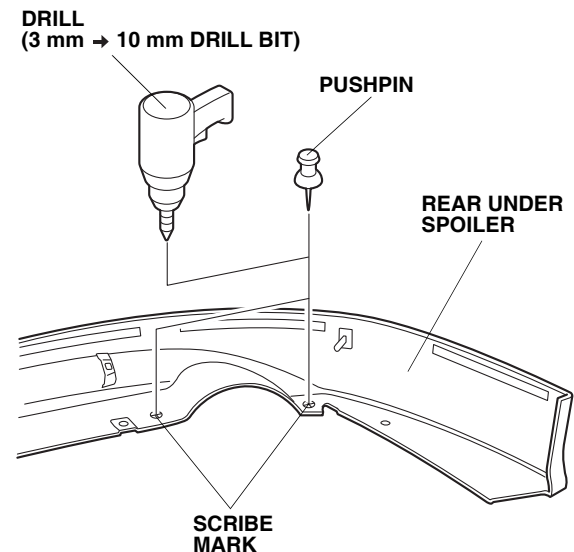

12. While wearing eye protection, drill a 3 mm hole through the mark from the rear under spoiler as shown. Finish with a 10 mm bit. Remove all burrs.

13. Attach a strip of masking tape to the end of the adhesive backing on the inner side of the finisher cover. Peel back the adhesive backing partway, and temporarily attach them to the surface side of the finisher cover as shown. Remove and discard the two remaining adhesive backings as shown.

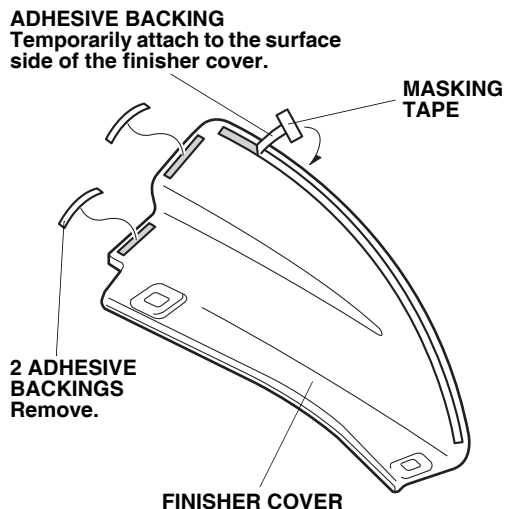

14. Position the finisher cover on the rear under spoiler, and install the two clips.

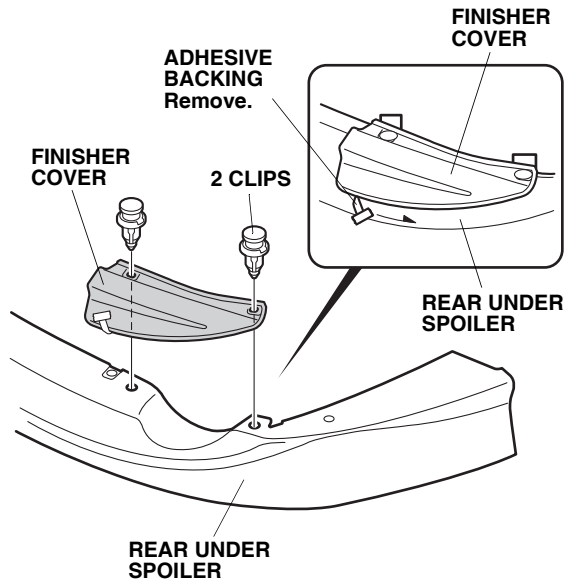

15. Press the finisher cover firmly while removing the adhesive backing that you temporarily attached to the surface side of the finisher cover.

16. Slide the four spring nuts onto the rear under spoiler.

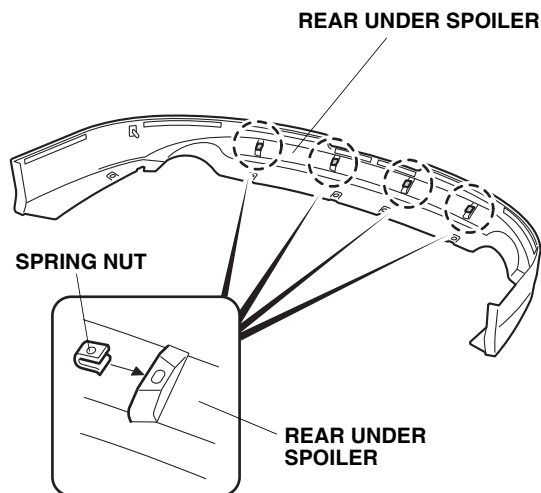

17. Attach a strip of masking tape to the end of each adhesive backing, and peel back 30 to 40 mm of the adhesive backings. Fold the ends back, and tape them to the front side of the rear under spoiler.

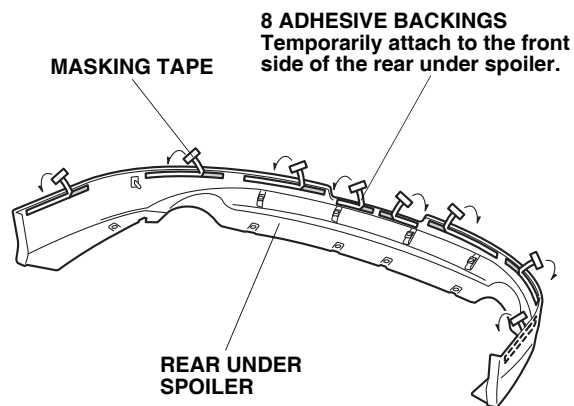

18. Using isopropyl alcohol on a shop towel, clean the rear bumper where the rear under spoiler will attach.
19. Position the rear under spoiler on the rear bumper. Fit the male clips on the rear bumper through the holes in the rear under spoiler, then install it with two collars A, two collars B, two washer bolts, and two flange nuts as shown.

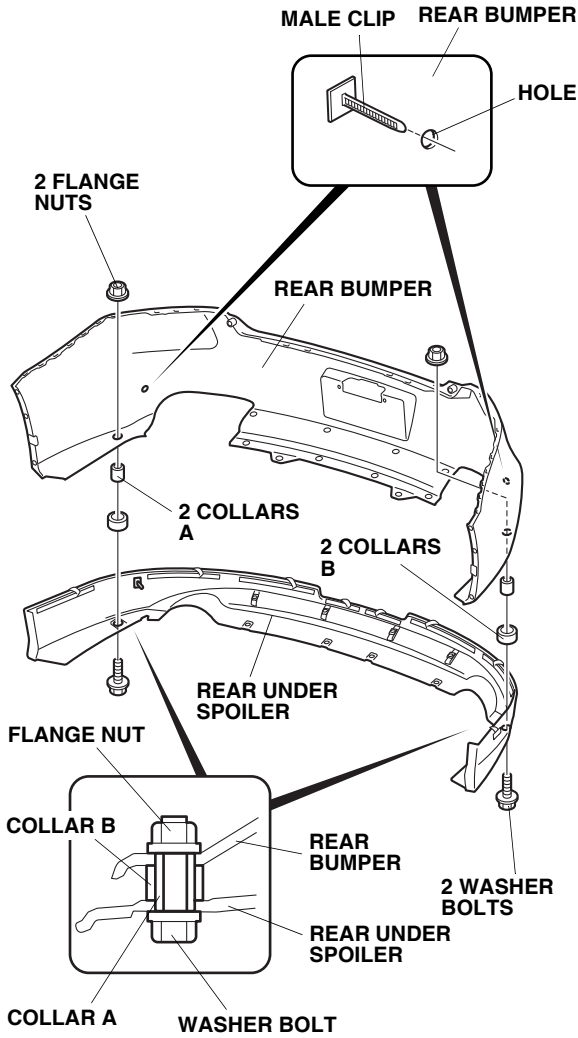

20. Secure the rear under spoiler to the rear bumper using four clips and two clip retainers as shown.

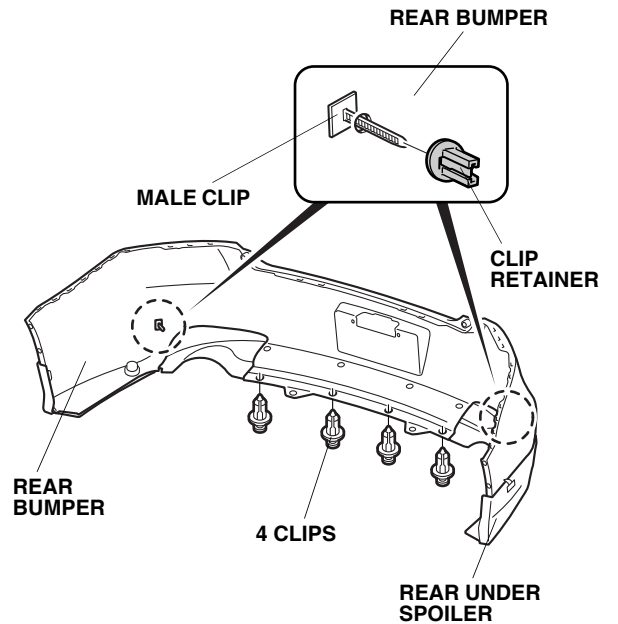

21. Secure the rear under spoiler to the rear bumper using four 5 x 14 mm self-tapping screws and four plain washers as shown.

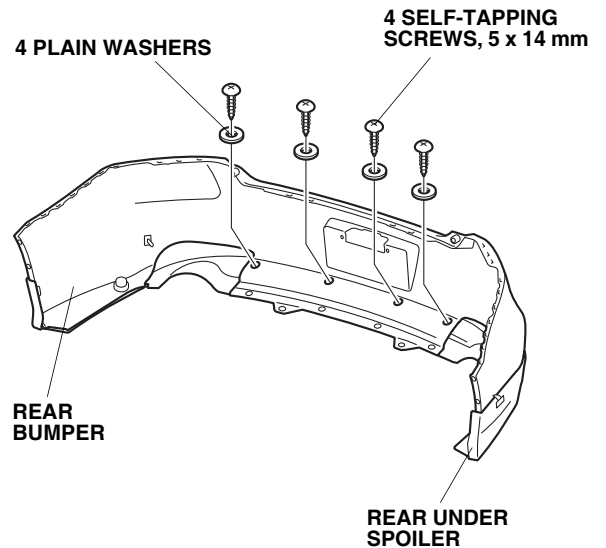

22. Install the rear bumper using two bolts (reused), two clips (reused), four self-tapping screws (reused), four 5 x 20 mm self-tapping screws, and connect one connector. If there is a gap, use one (or two) spacer(s) between the rear bumper and the rear under spoiler to prevent excess gaps.
- Using diagonal cutters, cut the spacers apart.
 - Spacer thicknesses of “1” and “2” represent 1 mm and 2 mm, respectively.
 - Do not use the spacers by combining the spacers of “2” together. This can prevent imbalanced installation of the rear under spoiler.

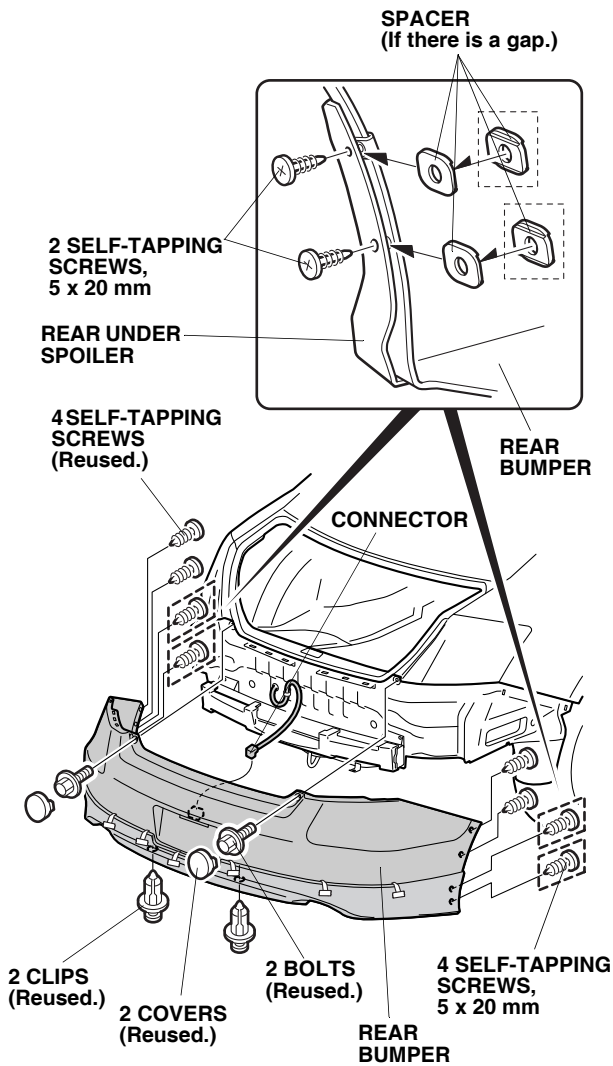

23. Reinstall the two covers to the rear bumper.

24. While applying pressure to the rear under spoiler, carefully remove the adhesive backings from the center outward. After removing the adhesive backings, hold the rear under spoiler firmly against the rear bumper with the palm of your hand for 30 seconds. Apply pressure to the bumper from the inside of the rear under spoiler and outside of the rear under spoiler with your hands as shown.

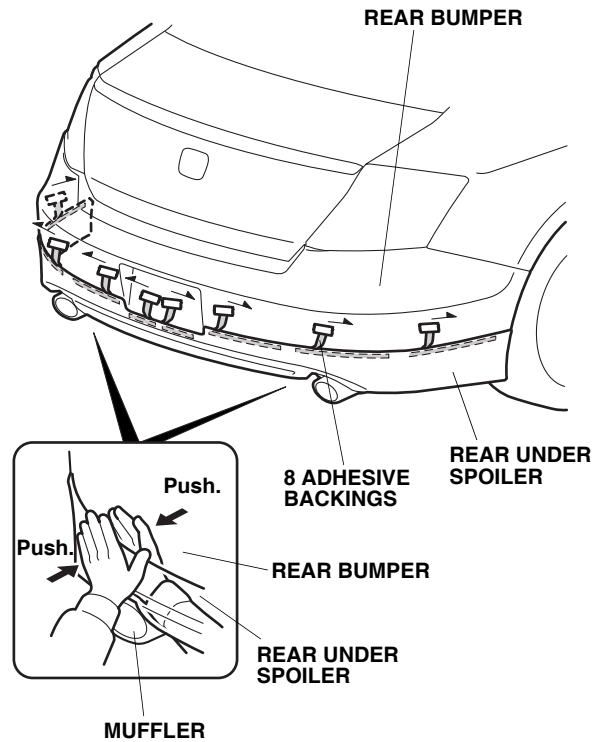

25. With a rubber roller, apply firm pressure while rolling to set the adhesive.

