



INSTALLATION INSTRUCTIONS

Accessory	Application	Publications No.
XM RADIO SYSTEM	2008 RIDGELINE	All 36647
		Issue Date MAY 2007

PARTS LIST

**Attachment Kit:
P/N 08B15-SJC-100**

2 XM tuner brackets

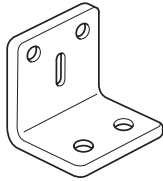

Bus cable

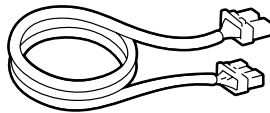

Double-side tape

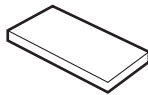

21 Wire ties

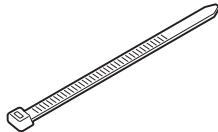

2 EPT sealers

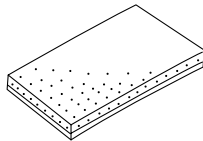

Cushion tape

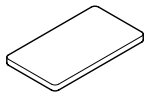

4 Flange nuts, 6 mm



5 Washer-screws, 5 x 8 mm



4 Washer-bolts, 6 x 16 mm

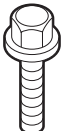

**XM Antenna (sold separately):
P/N 08A15-EX5-100B**

Antenna

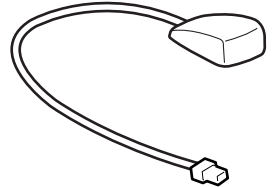

Splitter

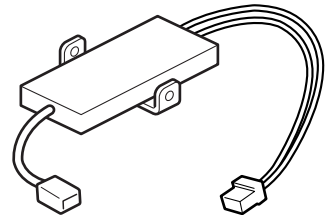

Connector clip



**XM Tuner (sold separately):
P/N 08A15-EX5-000**

XM tuner

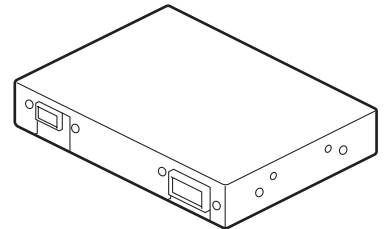

TOOLS AND SUPPLIES REQUIRED

Phillips screwdriver
Flat-tip screwdriver
10 mm Combination wrench
Ratchet
8 and 10 mm Socket
Isopropyl alcohol
Shop towel
Tape measure
Diagonal cutters
Felt-tip pen
Torx wrench

Illustration of the XM Radio installed in the Vehicle

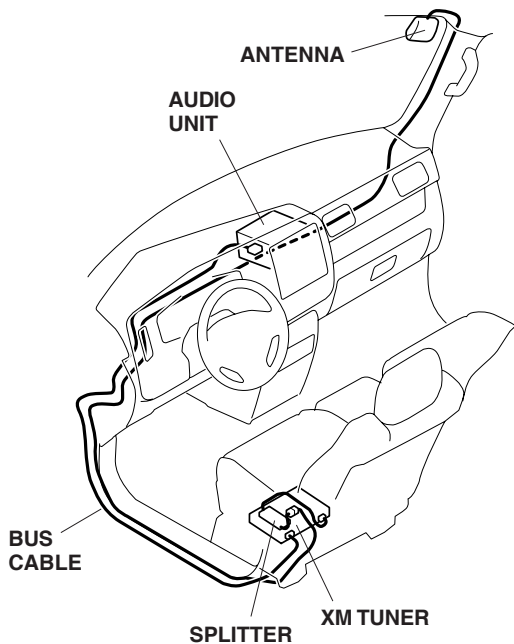

INSTALLATION

Customer Information: The information in this installation instruction is intended for use only by skilled technicians who have the proper tools, equipment, and training to correctly and safely add equipment to your vehicle. These procedures should not be attempted by “do-it-yourselfers.”

1. Make sure you have the anti-theft code for the radio, then write down the radio station presets.
2. Disconnect the negative cable from the battery.

3. Remove the passenger's front grab rail:
 - Remove the screw covers (two retaining tabs for each cover).
 - Remove the two screws, and remove the passenger's grab rail.

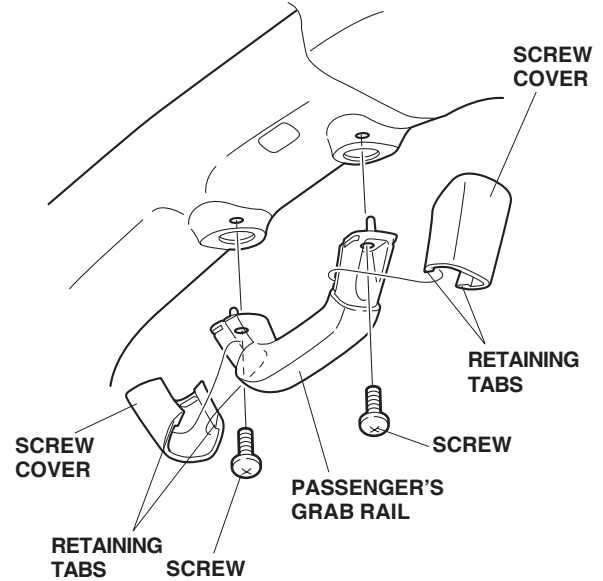

4. Pull away the weatherstrip from around the passenger's A-pillar. Remove the passenger's A-pillar trim (two clips).

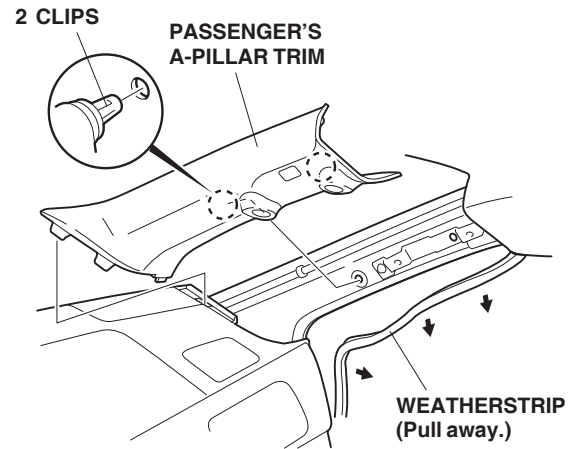

- Remove the right sunvisor screw cover (four retaining tabs), and remove the right sunvisor (two torx screws, and unplug the vehicle connector).

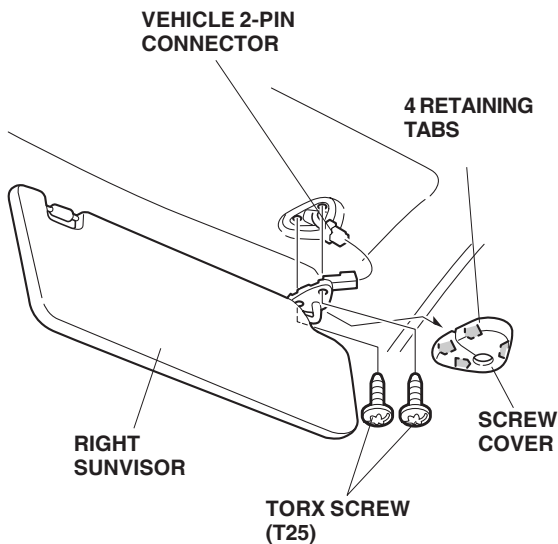

- Open the glove box. Remove the left and right stoppers from the glove box by releasing the retaining tabs.

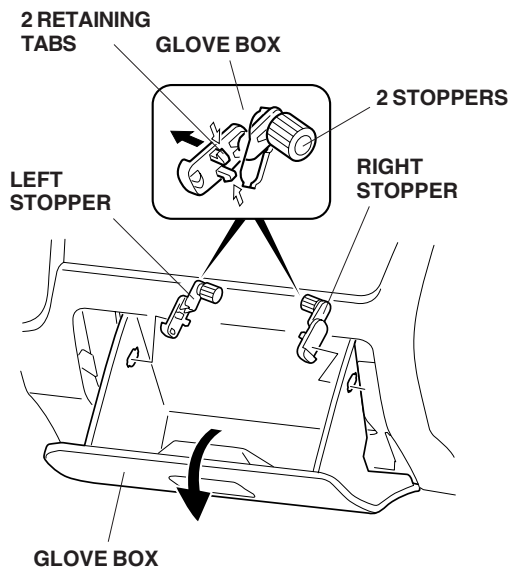

- Remove the left dashboard side cover (seven clips).

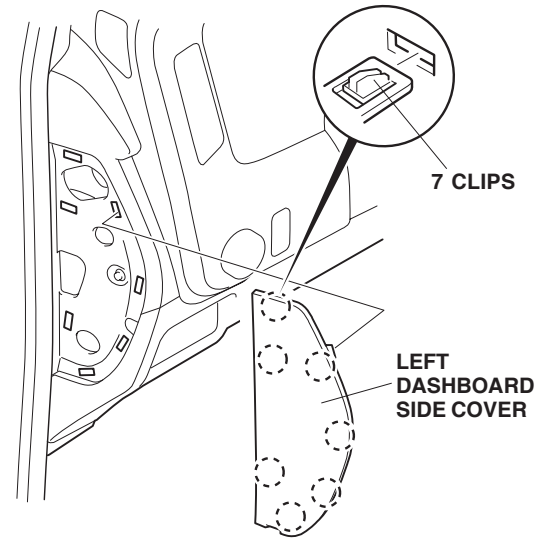

- Insert a flat-tip screwdriver wrapped with a shop towel into the groove of the instrument panel and release the two clips. Pull the instrument panel out toward you to release the eighteen clips, and remove the instrument panel by unplugging the vehicle connectors.

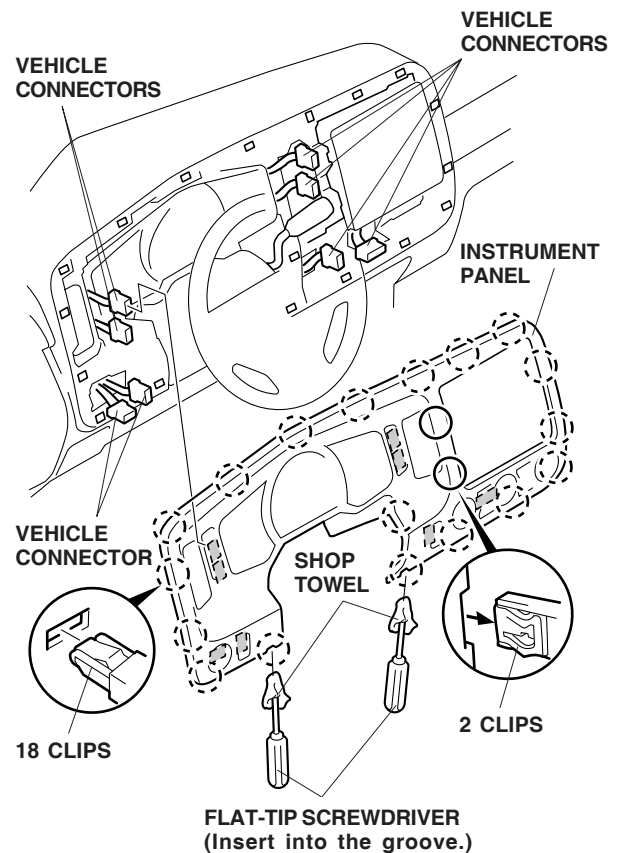

9. Remove the meter assembly (four self-tapping screws, and unplug the three vehicle connectors).

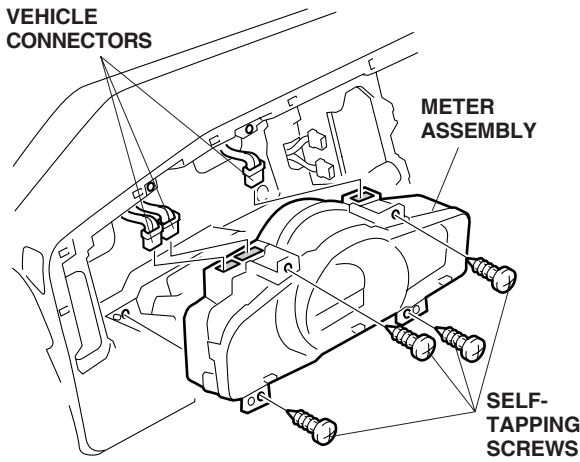

10. Remove the audio unit (five bolts, pull the audio unit out toward you, and unplug the vehicle connectors).

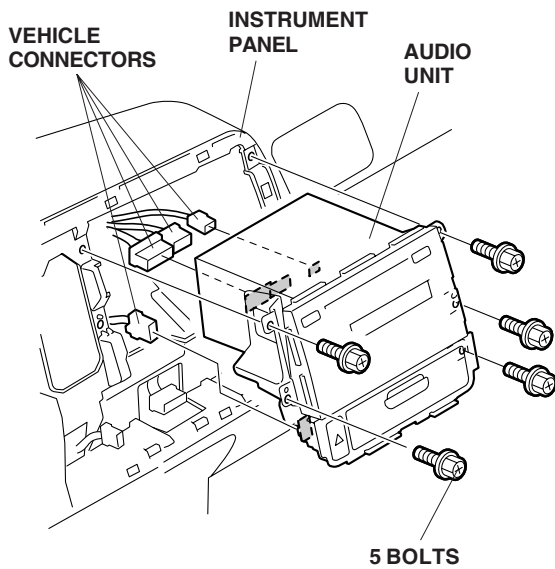

11. Remove the driver's dashboard under cover:

- Remove the one self-tapping screw.
- Release the nine clips, and pull out on the driver's dashboard lower cover.
- Unplug the vehicle connectors, and remove the vehicle tube. Remove the lower cover.

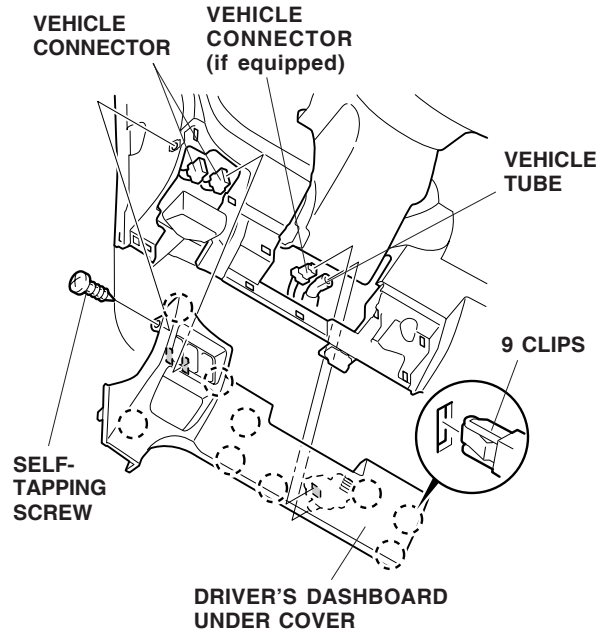

12. Remove the fuel fill door release handle. Remove the left front door sill trim (three clips and three retaining tabs).

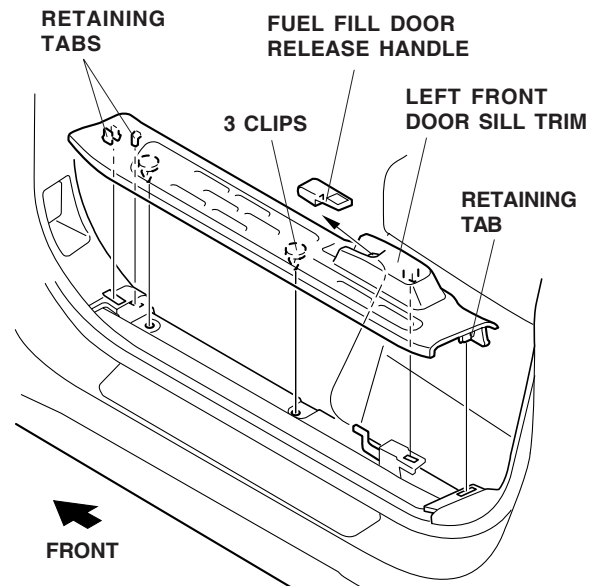

- Pull away the weatherstrip from around the driver's kick panel. Remove the driver's kick panel (one screw clip and one clip).

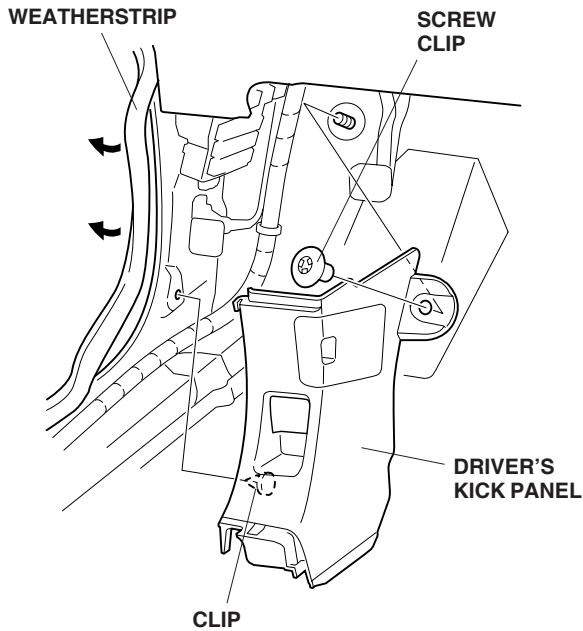

- Remove the driver's seat frame rear cover (two clips and two hooks).

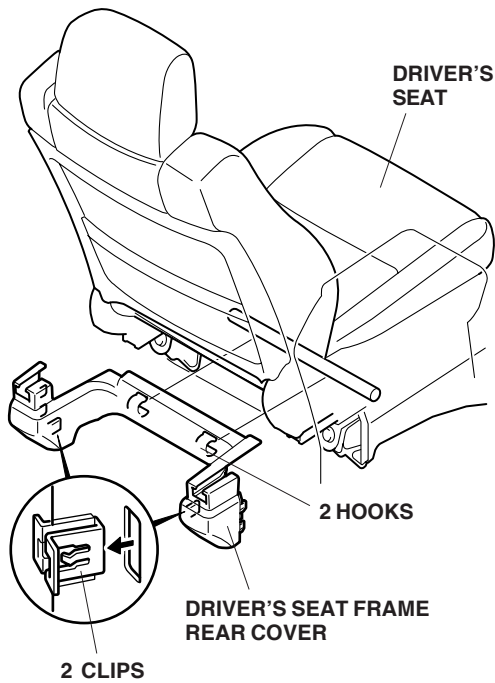

Installing the Antenna

- Using isopropyl alcohol on a shop towel, clean the right front upper corner on the inside of the front windshield. Remove the four adhesive backings from the antenna, and attach the antenna to the front window at the location shown. Install the antenna by applying sufficient pressure.

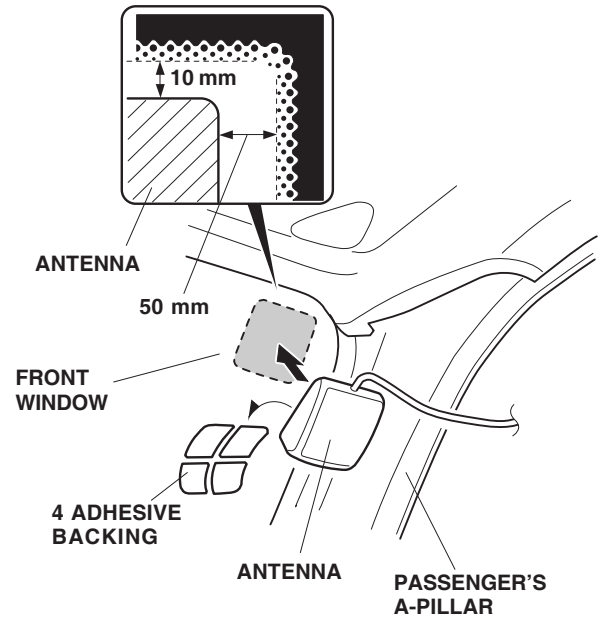

- Route the antenna harness down the passenger's A-pillar along the vehicle harness. Secure the antenna harness to the vehicle harness with three wire ties in areas shown.

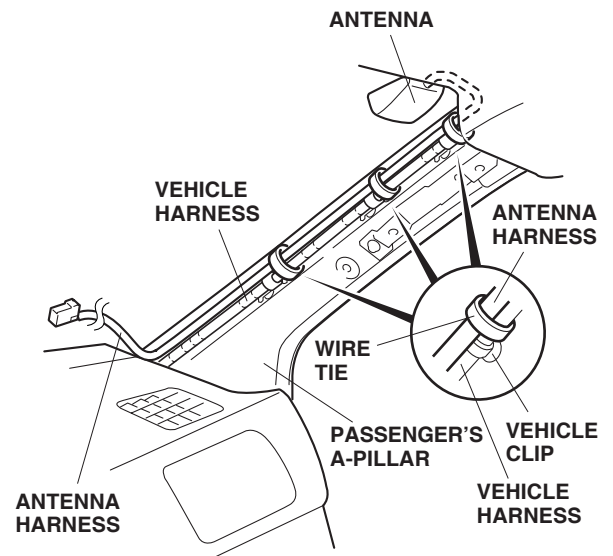

- Using a felt-tip pen, mark the antenna harness at the point where the harness touches the dashboard.

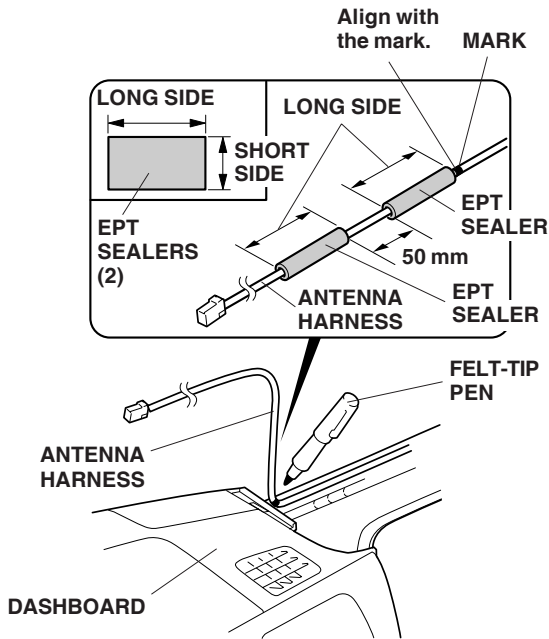

- Wrap two EPT sealers around the antenna harness at the locations shown.
- Route the antenna harness down behind the dashboard and toward the glove box. Secure the antenna harness to the vehicle harness with one wire tie.

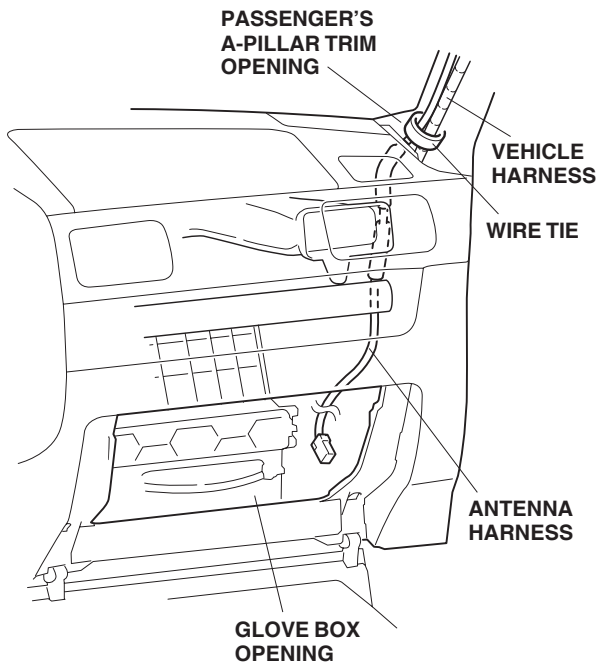

- Inside the glove box opening, route the antenna harness along the vehicle harness and toward the driver's side of the vehicle. Secure the antenna harness to the vehicle harness with three wire ties in the areas shown.

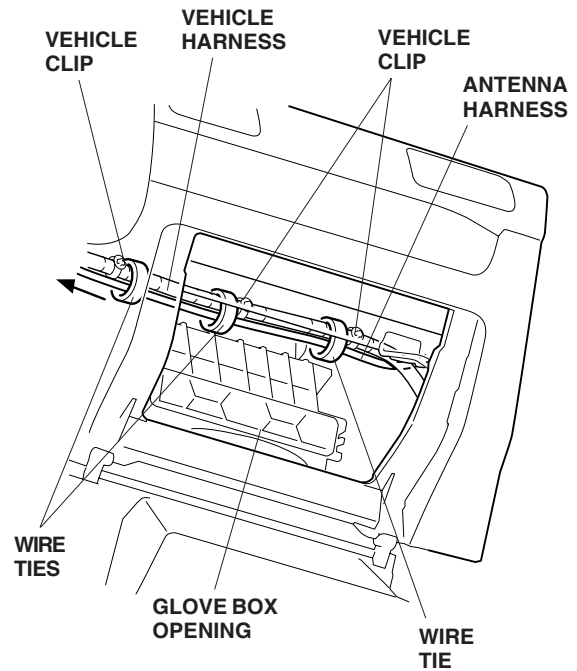

- Route the antenna harness past the audio unit opening, and secure the antenna harness to the vehicle harness with one wire tie.

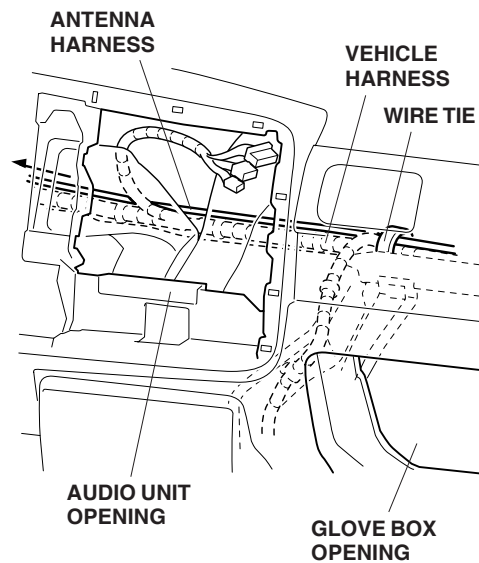

Routing the Bus Cable

- Get the bus cable from the kit. Align the bus cable 14-pin connector with the vehicle 20-pin connector, then route the other end of the bus cable toward the driver's side of the vehicle.

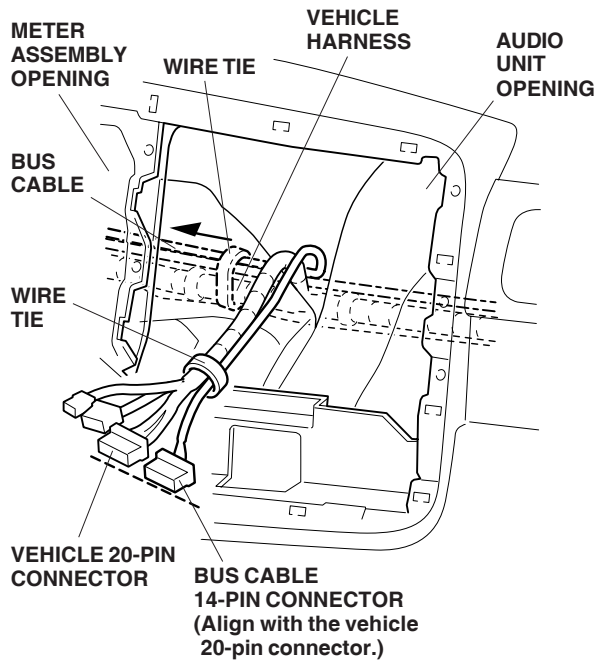

- Continue to route the bus cable and the antenna harness toward the driver's side of the vehicle; secure them to the vehicle harness with one wire tie.
- Plug the bus cable 14-pin connector and vehicle connectors into the audio unit/player.

With Player

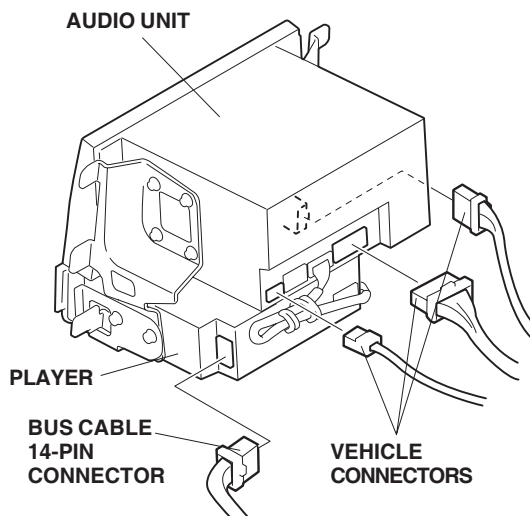

Without Player

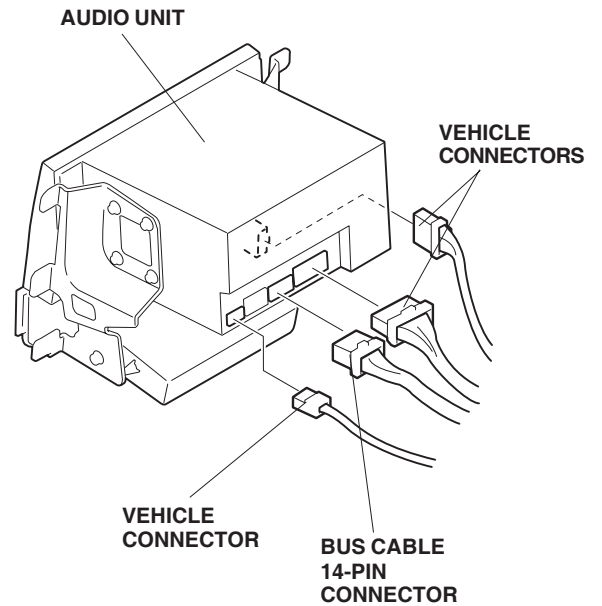

- Reinstall the audio unit.

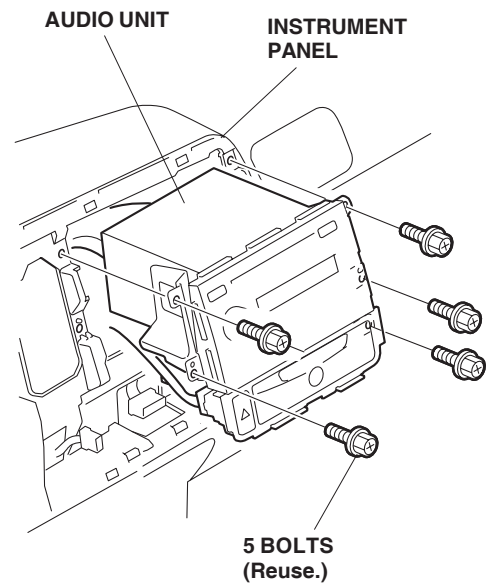

26. At the meter assembly opening, route the antenna harness and bus cable towards the driver's door, and secure them to the vehicle harness with two wire ties.

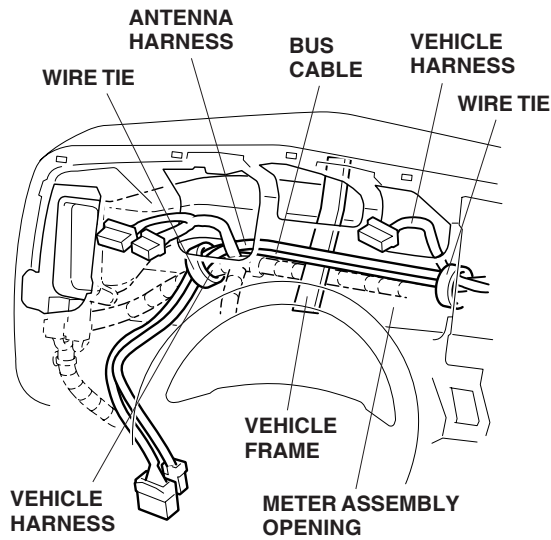

27. Route the antenna harness and bus cable down along the vehicle harness, and secure them to the vehicle harness with four wire ties.

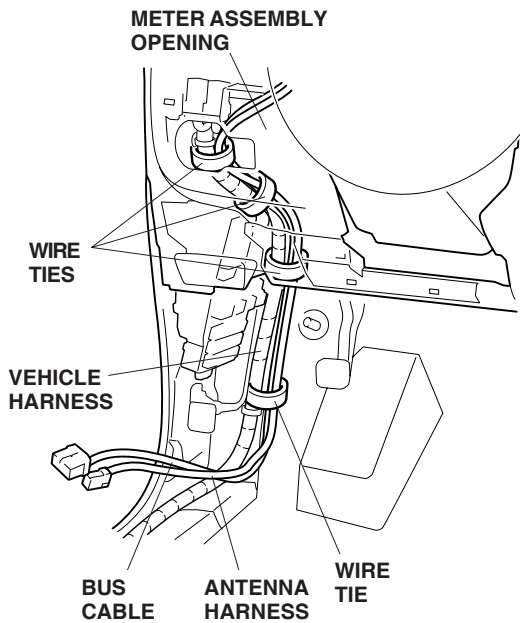

28. Route the antenna harness and bus cable along the vehicle harness at the door sill, and secure them to the vehicle harness with four wire ties.

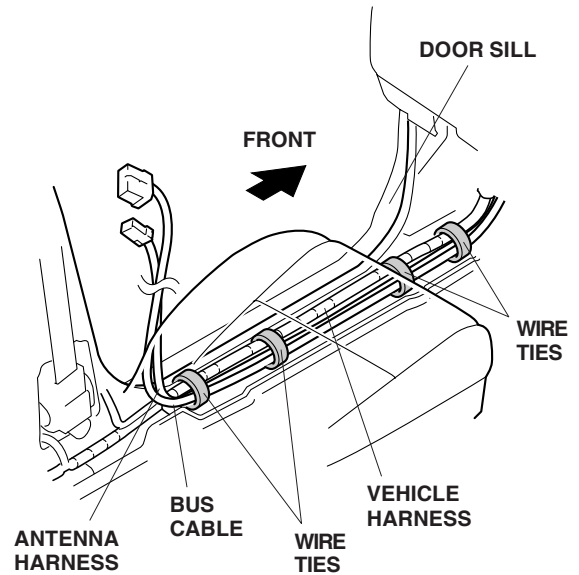

29. At the driver's seat, route the antenna harness and bus cable along the vehicle harness, and under the floor carpet, and pull them out through the cutout in the floor carpet.

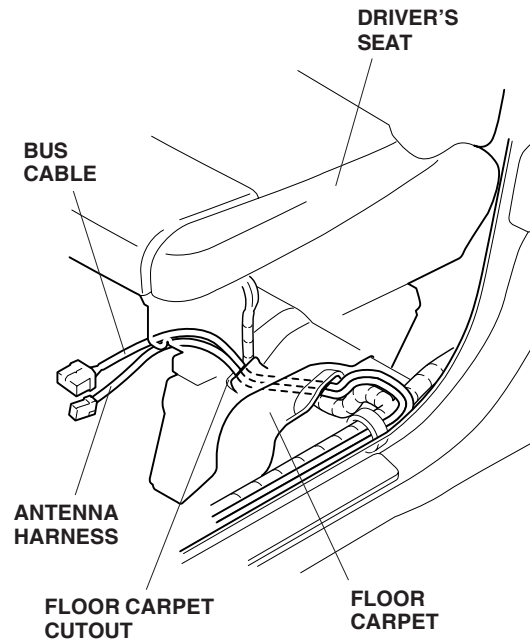

Installing the XM Tuner

30. Install the XM tuner brackets to the XM tuner with four 5 x 8 mm washer-screws.

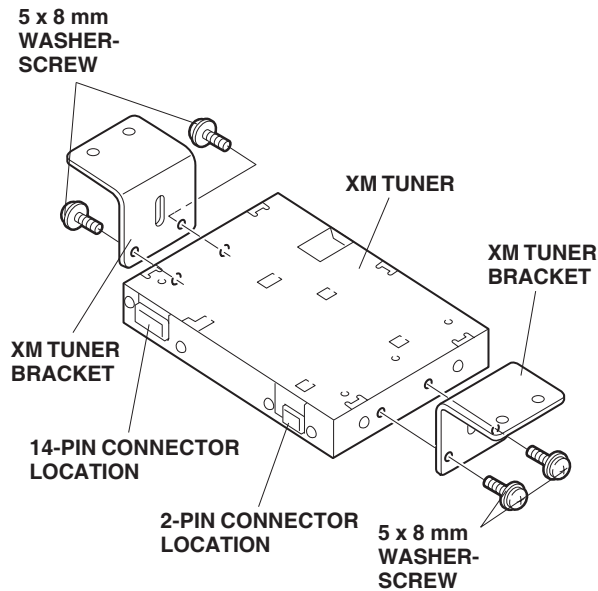

31. Using isopropyl alcohol on a shop towel, clean the XM tuner where the splitter will attach. Remove the adhesive backing from the double-side tape, and install the splitter to the XM tuner with the double-side tape at the location shown. Secure the splitter to the XM tuner bracket with one 5 x 8 mm washer-screw.

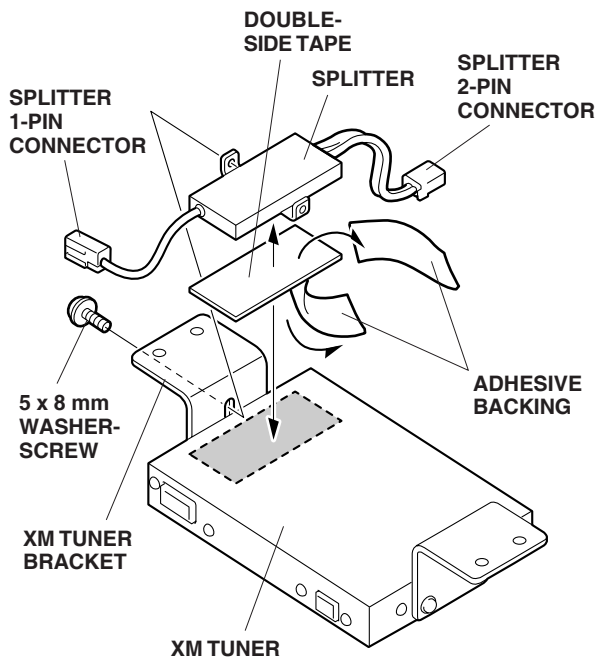

32. Plug the splitter 2-pin connector into the XM tuner.

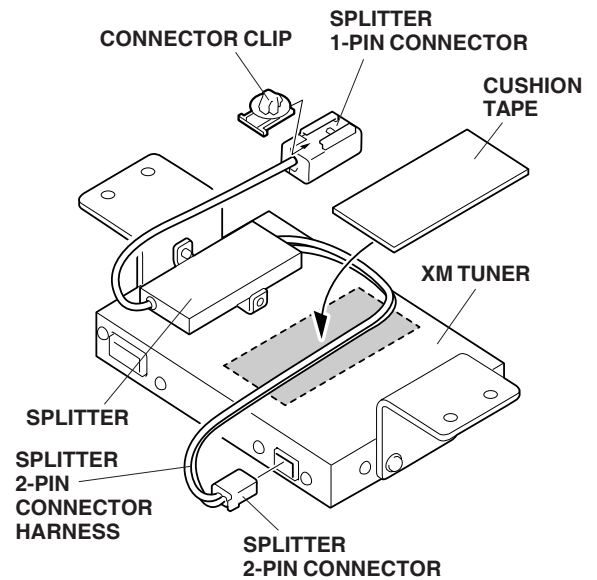

33. Using isopropyl alcohol on a shop towel, clean the XM tuner where the cushion tape will attach. Secure the splitter 2-pin connector harness to the XM tuner with one cushion tape.
34. Install the connector clip to the splitter 1-pin connector.
35. Install the XM tuner brackets to the driver's seat panel with four 6 x 16 mm washer-bolts and four 6 mm flange nuts.

NOTE: If the vehicle is equipped with welded nuts attached to the seat plate, the four flange nuts are not used.

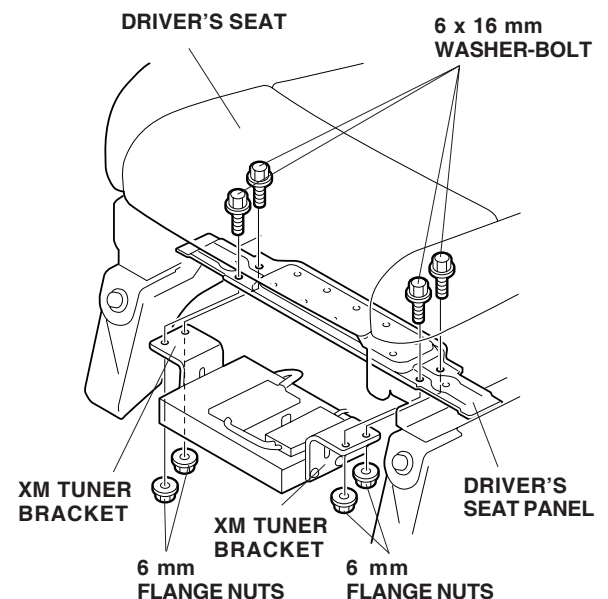

36. Connect the antenna harness 1-pin connector to the splitter 1-pin connector. Insert the connector clip installed in step 34 into the driver's seat panel hole in the area shown.

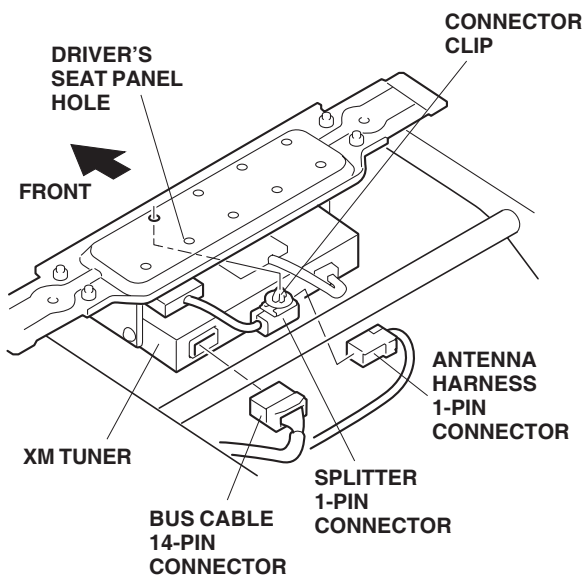

37. Plug the bus cable 14-pin connector into the XM tuner.
38. Loop the excess antenna harness and bus cable, and secure them to the driver's seat pipe with one wire tie.

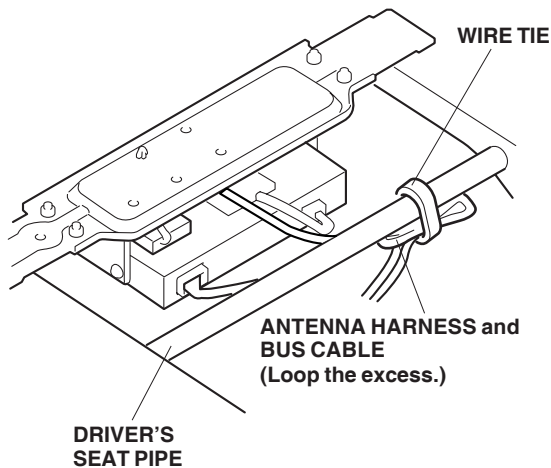

39. Slide the driver's seat back and forth to check that the antenna harness and bus cable are not pulled too tight or left too loose.

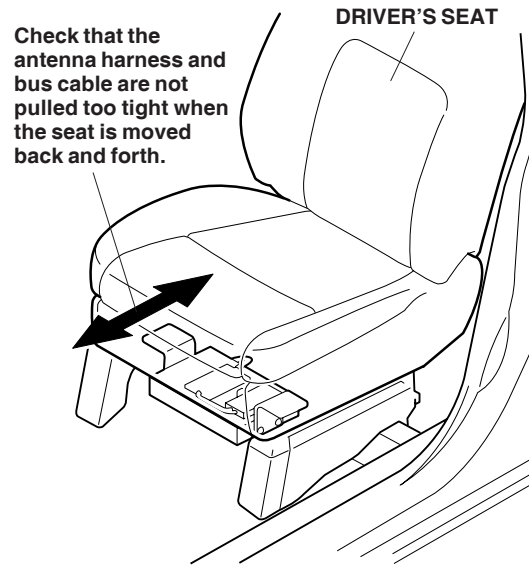

40. Check that all wire harnesses are routed properly, and all connectors are plugged in.
41. Reconnect the negative cable to the battery.
42. Enter the customer's radio anti-theft code, and reset the radio station presets.
43. Set the clock.
44. Check the operation of the XM radio system according to the vehicle's Owner's Manual supplied.
45. Reinstall all removed parts.

NOTE: Whenever the battery is disconnected, the driver's AUTO function is disabled.

46. Start the engine. Push down on the driver's window switch until the window is fully open.
47. Pull up on the driver's window switch fully to close the window completely, then hold the switch for 2 seconds or more.
48. Test the window AUTO function.