



INSTALLATION INSTRUCTIONS

Accessory

ENGINE BLOCK HEATER
P/N 08T44-SJA-200

Application

2008 RIDGELINE

Publications No.

All 36762

Issue Date

JUN 2007

PARTS LIST

Engine block heater

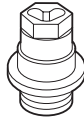

Aluminum washer



Heater harness

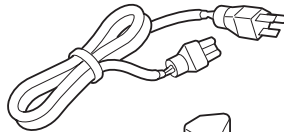

Protective cap

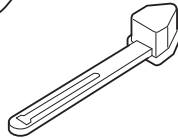

15 Wire ties
(5 Not used)

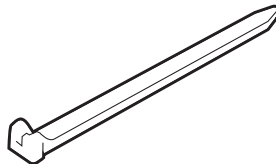

5 Wire tie with clips
(5 Not used)

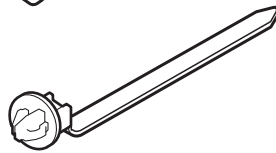

TOOLS AND SUPPLIES REQUIRED

Phillips screwdriver

Ratchet

19 mm and 24 mm Sockets

Torque wrench

Diagonal cutters

Coolant (Honda All Season Antifreeze/Coolant Type 2)

White marker

Tape measure

Diagonal cutters

NOTE

- Always use Honda All Season Antifreeze/Coolant Type 2. Using a non-Honda coolant can result in corrosion, causing the cooling system to malfunction or fail.
- To avoid burning out the element, do not operate the engine block heater before it is installed in the vehicle and before you add coolant.

INSTALLATION

Customer Information: The information in this installation instruction is intended for use only by skilled technicians who have the proper tools, equipment, and training to correctly and safely add equipment to your vehicle. These procedures should not be attempted by "do-it-yourselfers."

1. Allow the engine and all cooling system components to cool down.
2. Place a clean drain pan under the radiator drain plug, then remove the drain plug from the bottom of the radiator to drain the coolant. Remove the radiator cap to increase the flow.

NOTICE Radiator coolant will damage paint. Quickly rinse any spilled coolant from painted surfaces.

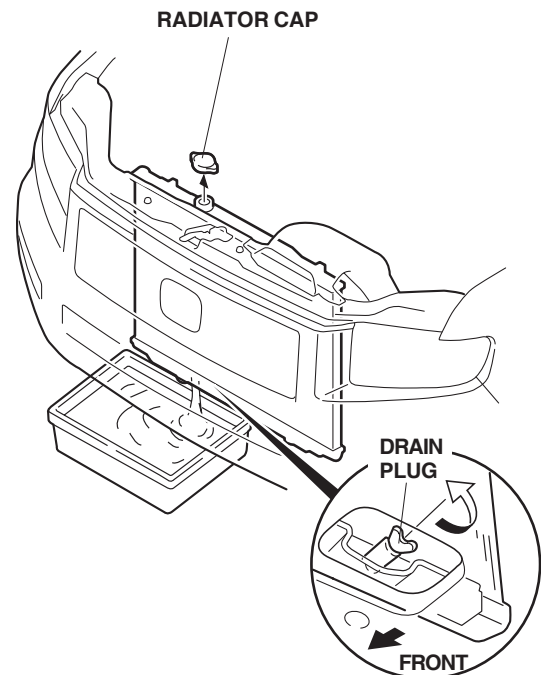

- Remove the drain bolt and washer from the front of the engine block. Coolant remaining in the engine jackets will flow out of the bolt hole when the drain bolt is removed. Retain the bolt, it can be reused if the engine block heater is removed.

NOTE: Use a new washer if the drain bolt is reinstalled.

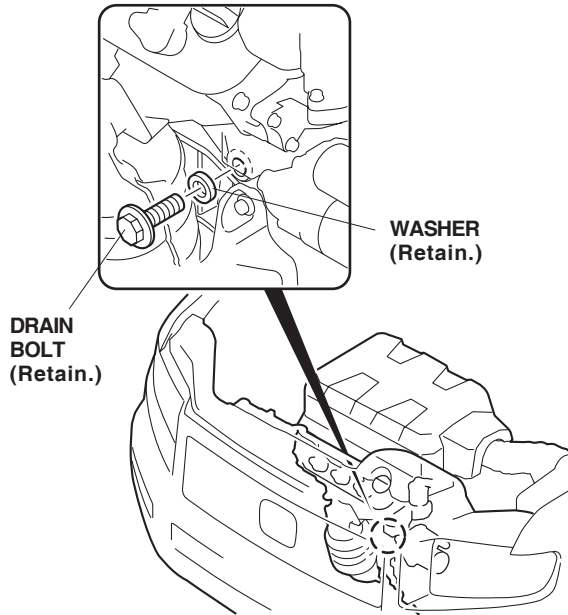

- Install the engine block heater with the aluminum washer into the hole using a 24 mm socket. Torque the engine block heater to 60 N·m (44 lb-ft).

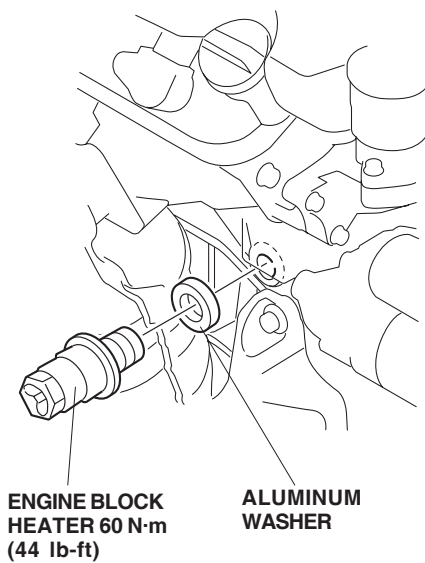

- Using a tape measure and white marker, measure and mark the heater harness at the measurements shown.

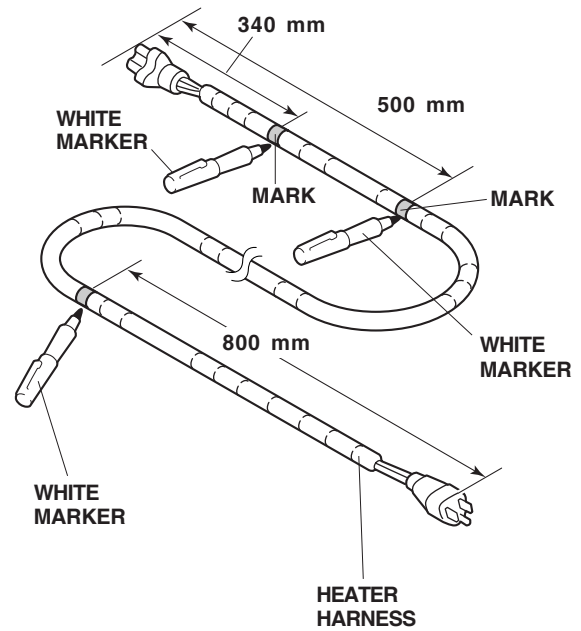

- Plug the heater harness connector into the engine block heater, and secure the heater harness to the vehicle harness with one wire tie at the white mark.

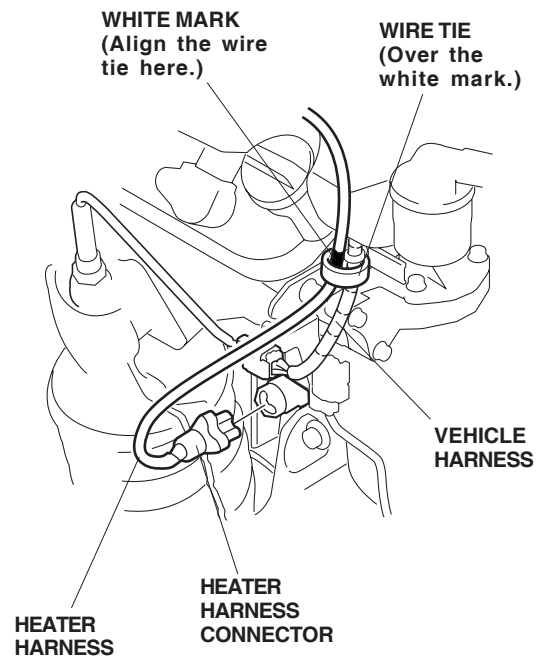

7. Route the heater harness over the fan shroud and along the vehicle harness. Secure the heater harness to the fan shroud and vehicle harness with six wire ties.

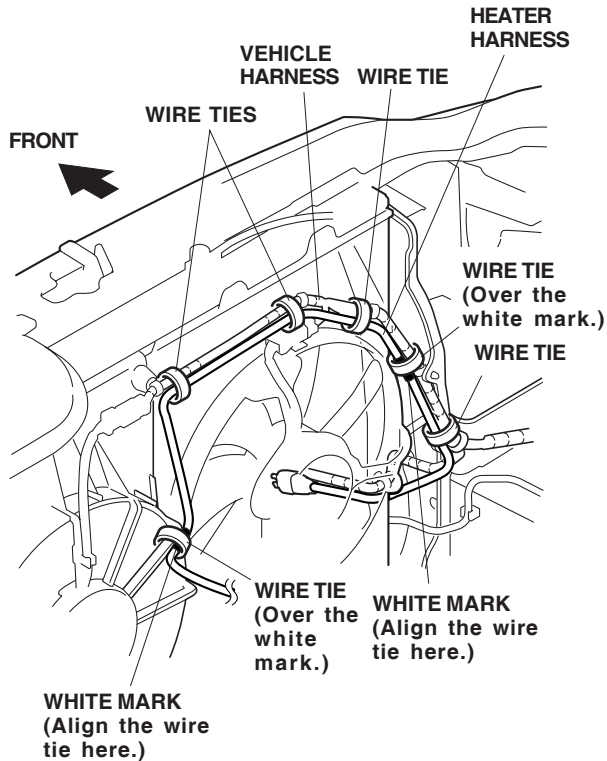

8. Continue routing the heater harness along the vehicle harness and down to the bumper grille opening. Attach the protective cap to the bumper grille, and plug the heater harness connector into the protective cap.

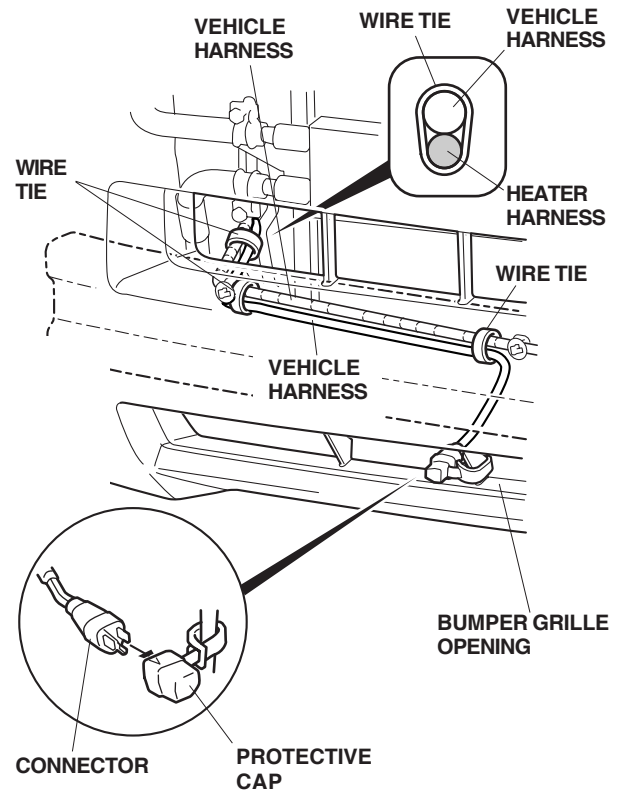

9. Secure the heater harness to the vehicle harness with three wire ties.
10. Reinstall the radiator drain plug.
11. Fill the system with the recommended coolant. Follow the instructions described in the service manual to fill and bleed the cooling system.
12. Check the coolant reservoir for correct level and check the cooling system for signs of leakage. Repair as necessary.
13. Check that the heater harness is routed properly and all of the connectors are plugged in.
14. Reinstall all removed parts.
15. Give the drain bolt (removed in step 3) to your customer.