



# INSTALLATION INSTRUCTIONS

Accessory <b>GOLD EMBLEMS</b> P/N 08F20-S9V-100F P/N 08F20-S9V-100G	Application  <b>2008 PILOT</b>	Publications No. <b>All 37168</b>
		Issue Date <b>JUNE 2007</b>

## PARTS LIST

Front gold "H" emblem

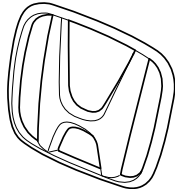

Rear gold "H" emblem

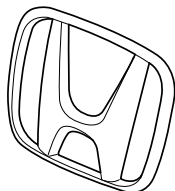

Rear gold "PILOT" emblem

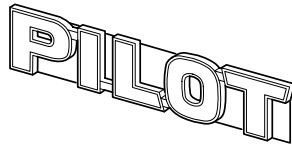

Rear gold "4WD" emblem



## TOOLS REQUIRED

- Phillips screwdriver
- Flat-tip screwdriver
- Ratchet
- 10 mm Socket
- 8 mm Combination wrench
- Masking tape
- Diagonal cutters
- Long nose pliers
- Isopropyl alcohol
- Shop towel
- String
- Blanket

## INSTALLATION

**Customer Information:** The information in this installation instruction is intended for use only by skilled technicians who have the proper tools, equipment, and training to correctly and safely add equipment to your vehicle. These procedures should not be attempted by "do-it-yourselfers."

### NOTE:

- Be careful not to damage the body paint finish when removing and installing the emblems.
- This emblem kit should be installed only if the ambient air temperature is 60°F (15°C) or above.
- To allow the adhesive to "cure," do not wash the vehicle for 24 hours.

### Installing the Front Gold "H" Emblem

1. Open the hood. Remove the front bulkhead cover (13 clips).

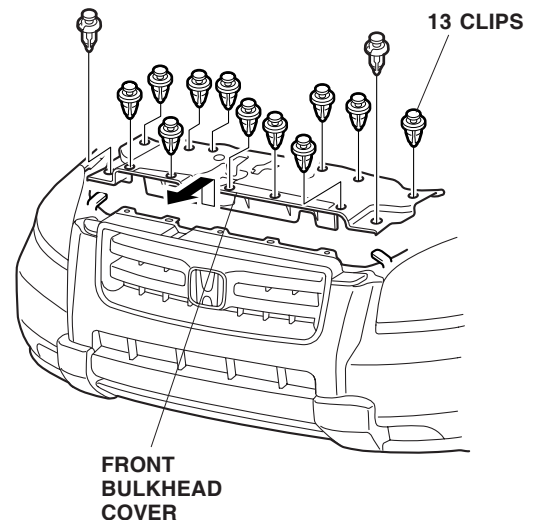

- Remove the front bumper (two short clips, two self-tapping screws, four bolts, and two long clips). To prevent damage, rest the bumper on a blanket.

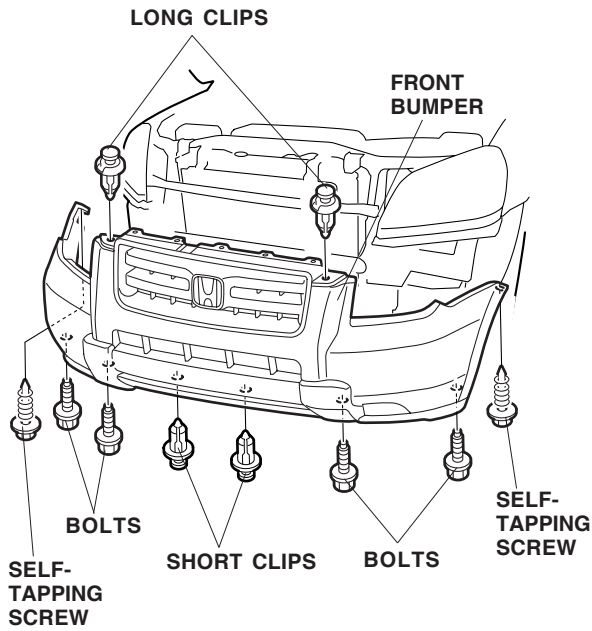

- Remove the front "H" emblem (two self-tapping screws).

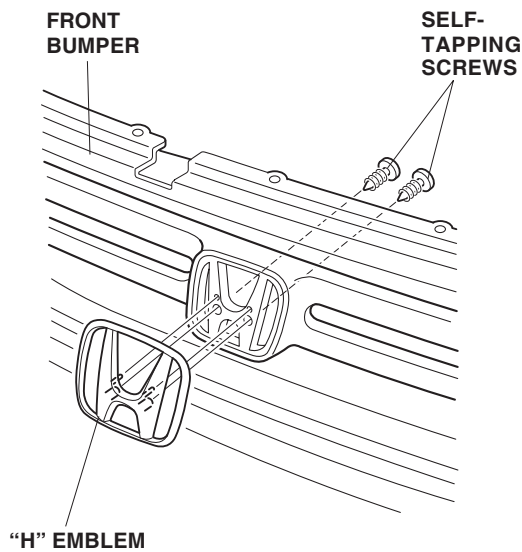

- Attach the gold "H" emblem to the front bumper with the two self-tapping screws you removed.

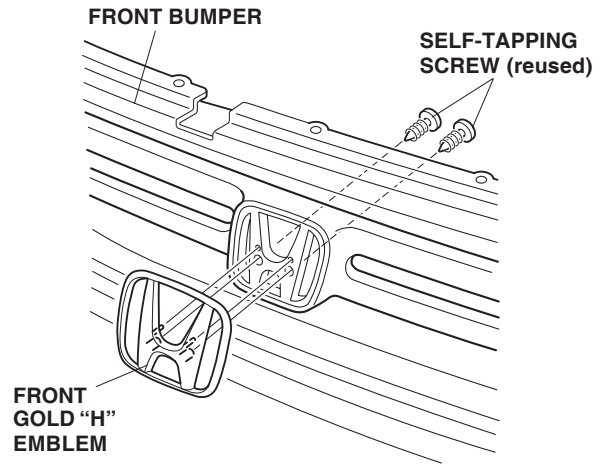

- Reinstall the front bumper. Check that the clips are installed securely.

#### Installing the Rear Gold "H" Emblem

- Open the tailgate. Remove the tailgate upper trim (two retaining tabs and four clips).

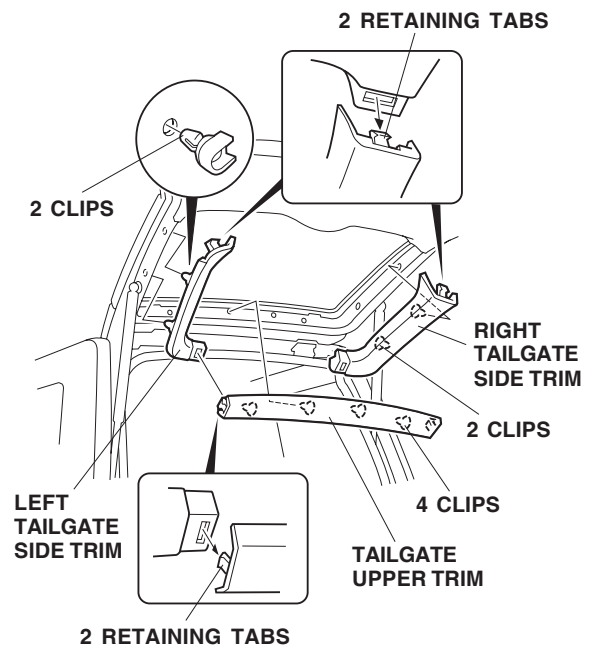

- Remove the right and left tailgate side trims (one retaining tab and two clips).

- Remove the two covers from the grab rail, then remove the two screws concealed under the covers. Remove the grab rail.

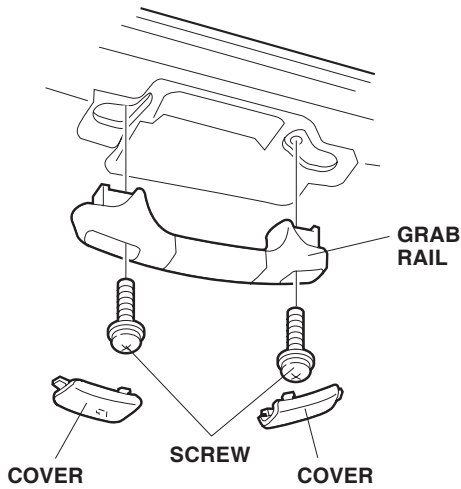

- Remove the tailgate rear trim:
  - Release the two clips that secure the bottom of the tailgate rear trim.
  - Release the 11 clips, and pull the tailgate rear trim away from the tailgate.
  - Unplug the vehicle connector, and remove the tailgate rear trim.

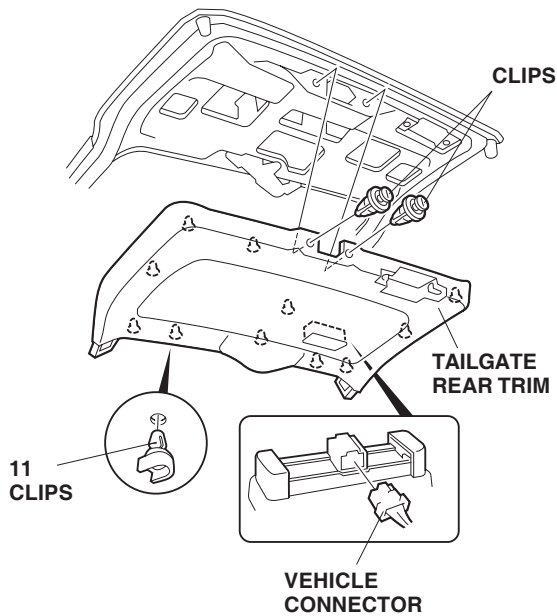

- Disconnect the two connectors from the back-up lights.

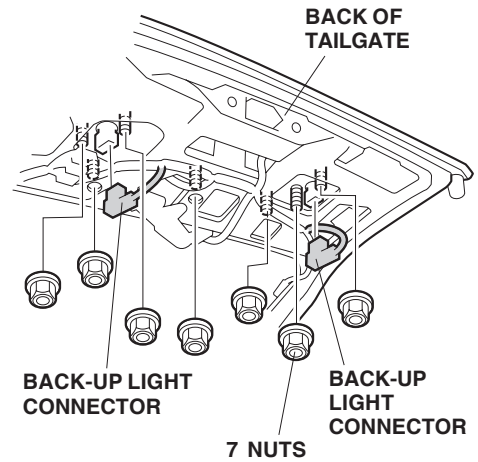

- Remove the seven nuts from the back of the tailgate.
- Release the four clips, and remove the rear license trim. If the clips are hard to remove, use an 8 mm combination wrench to pry three of them loose. Use a clip remover to remove the last clip under the body panel.

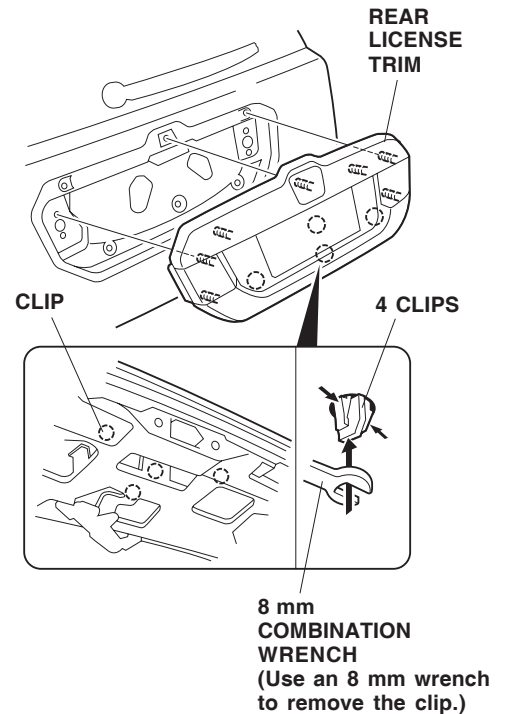

- Remove the "H" emblem from the rear license plate trim (two screws).

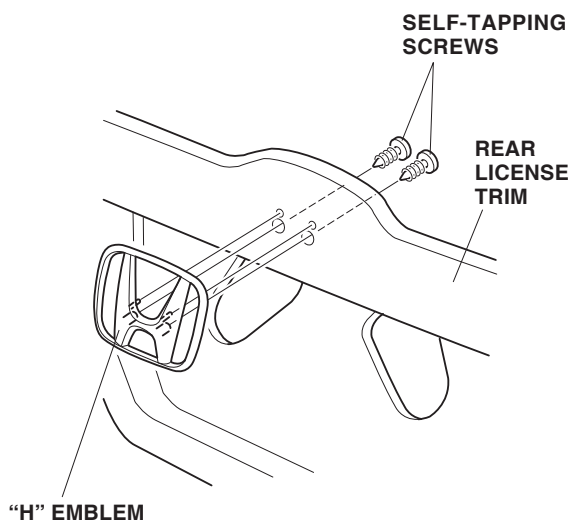

- Attach the gold "H" emblem to the rear license trim with the two self-tapping screws you removed.
- Reinstall all removed parts.

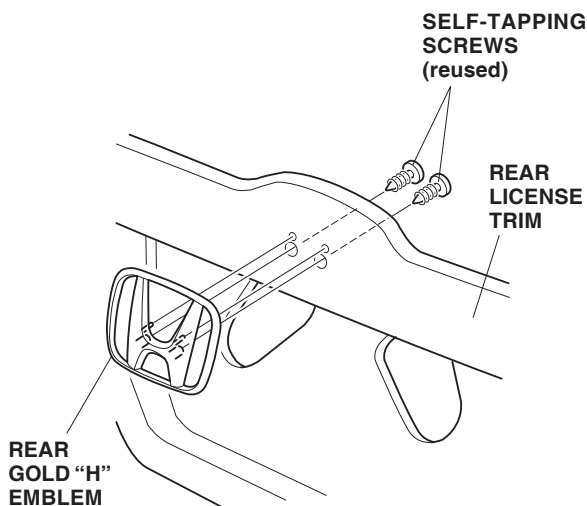

**Installing the Rear Gold Emblem(s)**

- Mark the locations of the existing "PILOT" emblem by applying masking tape along the four edges of the emblem.
- Remove the original rear emblem by cutting the

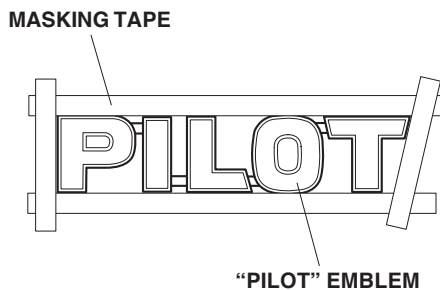

outer edges with a piece of string.

- Using isopropyl alcohol on a shop towel, clean the

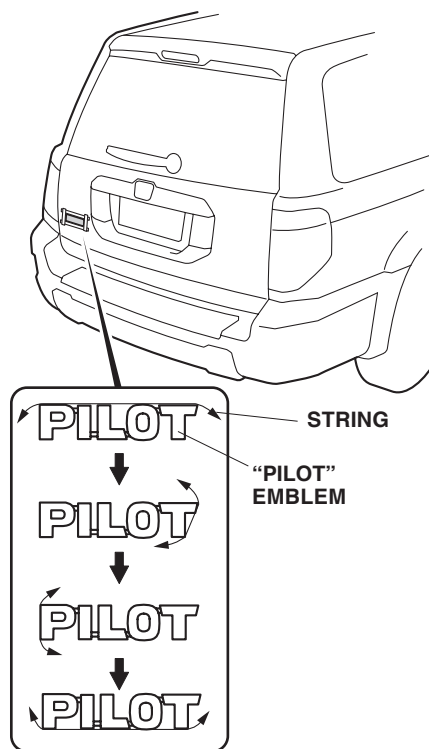

- area where the emblem was removed.
- Remove the adhesive backing from the gold

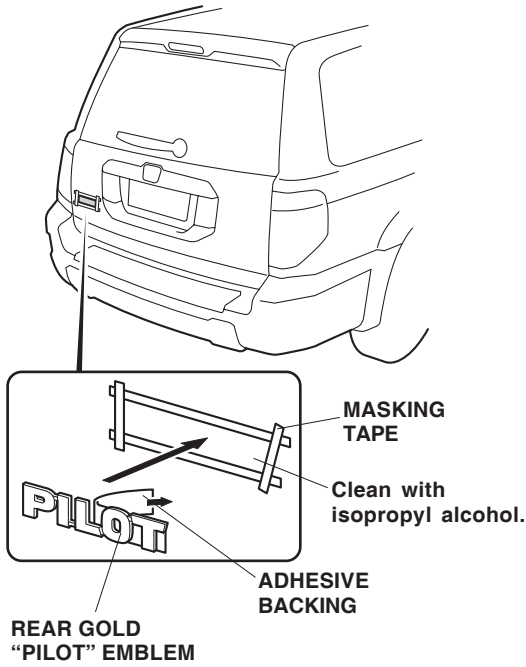

"PILOT" emblem, and attach the emblem to the tailgate.

- Press the emblem firmly against the body with the palm of your hand for 30 seconds.
  - Remove the masking tape.
- Replacing the 4WD emblem (if equipped)**

- Mark the locations of the existing "4WD" emblem by applying masking tape along the four edges of the emblem.
- Remove the original rear emblem by cutting the

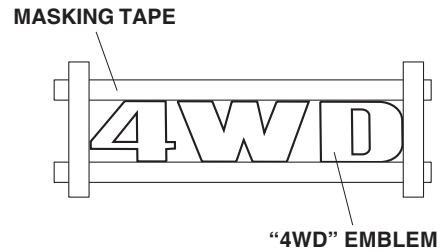

- outer edges with a piece of string.
- Using isopropyl alcohol on a shop towel, clean the

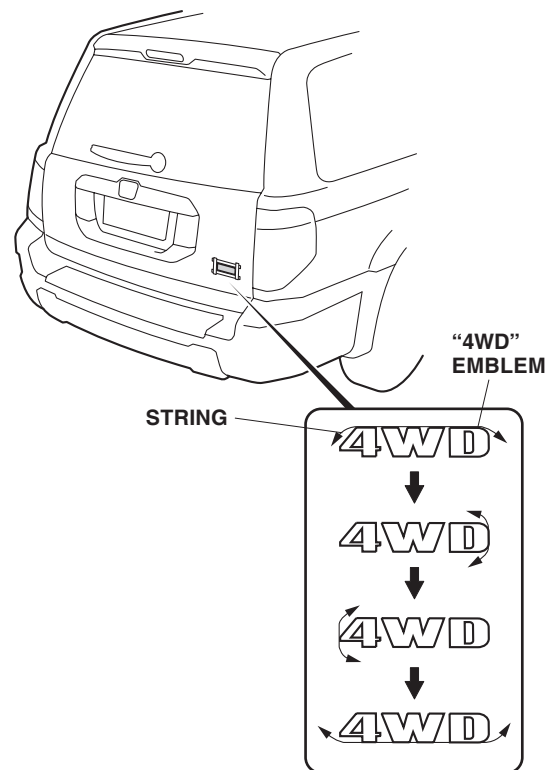

area where the emblem was removed.

25. Remove the adhesive backing from the gold

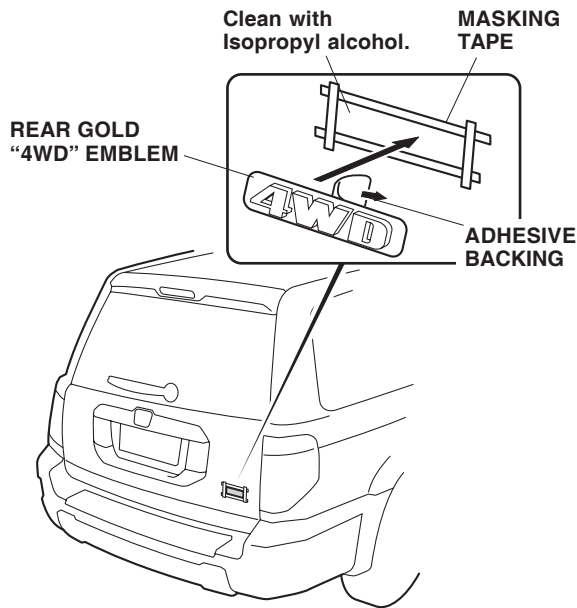

"4WD" emblem, and attach the emblem to the tailgate.

26. Press the emblem firmly against the body with the palm of your hand for 30 seconds.
27. Remove the masking tape.

**NOTE:** After the emblem kit is installed, tell your customer not to wash the vehicle for 24 hours to give the adhesive time to cure.